



OUTDOOR STORAGE

MODEL N° 60005

***OWNER'S MANUAL***

COPY

Keep this Identification Number in case you must contact our Customer Service Department.

## **IMPORTANT! PLEASE READ BEFORE BEGINNING ASSEMBLY**

Dear Valued Customer,

We would like to congratulate you on your purchase of a Lifetime® Outdoor Storage Shed! We are confident that you have made the perfect choice and you will be very pleased with your new storage solution.

Lifetime® Outdoor Storage is part of the family of products created and manufactured by Lifetime® Products, Inc. Like all of our products, you can be assured that the quality of your Lifetime Outdoor Storage Shed is the best in the world! And, we back that quality up by offering the best warranty in the business – A 10-year warranty that fully covers the Shed!

All of our Sheds are built with the highest-quality steel and high-density polyethylene (HDPE) parts. The design and construction of our steel-reinforced double-Wall Panels is second to none. All of our exposed steel parts and gables are powder coated and we use high-density polyethylene plastic. What makes polyethylene so special? It has superior strength and durability, and, it won't crack or degrade outdoors.

So now that you know the quality you are getting in a Lifetime Outdoor Storage Shed, please take the time to READ THIS INSTRUCTION MANUAL!

We have taken great care in providing the best possible form of instructions to help you put your new Outdoor Storage Shed together. Before you get started, PLEASE read the following preparation tips to help you get started!

We can assure you, your construction experience will be a lot more enjoyable if you do!

### PREPARATION TIPS:

- The first step is simple... RELAX! You have made a great purchase, but Rome was not built in a day. Plan to spend a good part of your weekend putting together your fine Outdoor Storage Shed. Our philosophy is, if it comes together quickly and easily, it surely will come apart quickly and easily! Your Lifetime® Outdoor Storage Shed will surely last a long, long time, if you are patient, and take all the time necessary to put it together as we have instructed.
- Grab a friend to join in on the fun! This is not a one-person endeavor. We have found that not only will things go smoother if you have two or more people participating in the construction of the Shed, but it will go quicker as well. So, the more the merrier!
- Make sure you have all the tools necessary for constructing your new Shed. There is a "Tools Required For This Assembly" list on page five of this Owner's Manual.
- The plastic pieces of your Shed may become damaged by over tightening the screws. To avoid this damage, we strongly recommend the use of a low-powered power screwdriver or a drill that has an adjustable clutch that is set on a low-torque setting. If neither is available, use a hand screwdriver. If a hand screwdriver is all you have, take several breaks... your wrist will need it!
- You will also need two small ladders (when it comes time to do the roof!).

## **IMPORTANT! PLEASE READ BEFORE BEGINNING ASSEMBLY**

- Before beginning assembly, remove the Parts List from the center of this Owner's Manual and take an inventory of the parts included with your Outdoor Storage Shed. Also, read through the entire instruction manual. It's always a great practice to get a feel for the flow of the process and to familiarize yourself with the parts involved. But, try not to get ahead of yourself and start the process out of order.
- FOLLOW THE INSTRUCTIONS IN ORDER! Everything goes together in a certain order, and we have learned what that correct order should be. In our state-of-the-art research and testing facility, we have painstakingly created these instructions. The order of construction is there for a reason, and some parts simply will not fit if built out of order. Just follow along with the order in the instructions and everything will fit together and things will go very smooth.
- YOUR SHED MUST BE BUILT ON A LEVEL SURFACE! If the spot you have chosen to place your wonderful new Outdoor Storage Shed is not level, the Shed will not assemble correctly! We recommend a concrete patio, a wood platform or creating a pad with pea gravel. Your Shed is meant to last a lifetime, so provide the proper foundation for it before you start to build.
- Before you build it, make sure you are allowed to build it! Consult all building codes, as well as city and county ordinances, to ensure that you do not require a building permit to construct your Outdoor Storage Shed. Proper building permit documentation may be required in your neighborhood, and it would be quite unfortunate to learn this after your Outdoor Storage Shed is already built!

Now that you're ready to begin the construction of your wonderful new Outdoor Storage Shed, step back, take a deep breath, get yourself a large cold beverage and enjoy yourself. We guarantee that after spending the right amount of time in building your Shed, you will be able to enjoy it for years to come.

Thanks for choosing Lifetime©, and have fun!

## **ABOUT LIFETIME PRODUCTS, INC.**

Lifetime Products, Inc., has applied innovation and cutting-edge technology in plastics and metals to create a family of affordable lifestyle products that feature superior strength and durability. The world's leading manufacturer of folding tables and chairs, Lifetime was founded in 1986 as the maker of portable basketball systems that revolutionized the industry with patented technology. With diverse offerings such as outdoor storage sheds and steel utility trailers, Lifetime continues to develop innovative products that outfit the way you live.

Lifetime makes the things you need for the lifestyle you want. By innovating products in and around the home, Lifetime simplifies your everyday life and enables you to get the most out of your free time.



## REGISTER YOUR LIFETIME PRODUCT TODAY!

There are benefits to registering your Lifetime product. With our new online product registration form, it's fast and easy! Register with us at [www.lifetime.com](http://www.lifetime.com) and enjoy these great benefits:

- Receive exclusive money-saving offers from BuyLifetime.com, our online store, as well as NEW product notifications and special closeout promotions!
- In the unlikely event of a product recall or safety modification, we will notify you.
- Registering your product guarantees you warranty service. If you do not register your product, your warranty rights will not be diminished. But you will need to provide a sales receipt to verify your product purchase date before warranty service will be provided.

### LIFETIME'S PROMISE TO YOU:

*Maintaining your privacy is our long-standing policy at Lifetime. And you can rest assured that Lifetime will not sell or provide your personal data to other third parties, or allow them to use your personal data for their own purposes.*

We invite you to read our privacy policy at [www.lifetime.com](http://www.lifetime.com)

**REGISTER today!**

### **\*\*U.S. and Canada customers ONLY\*\***

IF ASSISTANCE IS NEEDED,

## **DO NOT CONTACT THE STORE!**

**CALL OUR CUSTOMER SERVICE DEPARTMENT at 1 (800) 225-3865**

HOURS: 7:00 a.m. to 5:00 p.m. Monday through Friday (Mountain Standard Time)

\*\*Call, or visit our Web site for Saturday hours\*\*

\*\*For customers outside the U.S. or Canada, please contact the store for assistance.\*\*



## SAFETY INSTRUCTIONS



### **FAILURE TO FOLLOW THESE WARNINGS MAY RESULT IN SERIOUS INJURY OR PROPERTY DAMAGE AND WILL VOID WARRANTY.**

To ensure safety, do not attempt to assemble this product without following the instructions carefully. Check entire box and inside all packing material for parts and/or additional instruction material. Before beginning assembly, read the instructions and identify parts using the hardware identifier and parts list in this document. Proper and complete assembly, use and supervision are essential to reduce the risk of accident or injury.

- Do not use or store hot objects such as grills, blowtorches, welding equipment, etc. near the product.
- If using a ladder during assembly, use extreme caution.
- Two capable adults are required for assembly. (It is also recommended that a third adult function as an instruction reader.)

*Most injuries are caused by misuse and/or not following instructions. Use caution when using this product.*



## BEFORE BEGINNING ASSEMBLY



Keep the hardware bags and their contents separate. If any parts are missing, call our Customer Service Department.



Read the “Congratulations” letter on page 2-3. Identify and inventory all parts and hardware using the parts and hardware lists and identifiers in this document.

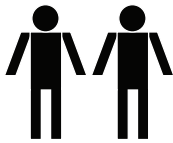

***\*Two adults required to complete assembly\****

**Only adults should set up the product. Do not allow children in the set-up area until assembly is complete.**



## TOOLS REQUIRED FOR THIS ASSEMBLY

7/16"



(2)

3/8"



(1)

Adjustable



(1)

Hammer

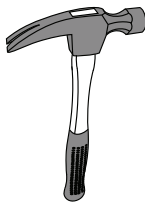

(1)

Rubber Mallet



(1)

Box Knife



(1)

Phillips  
Screwdriver



(1)

Plain  
Screwdriver



(1)

3/8" Masonry  
Bit



(1)

Level



(1)

2" x 4" x 8'  
Leveling Board



(1)

6' Ladder



(2)

Power Drill\*



(1)

Work Light

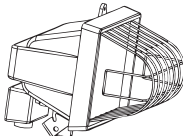

(1)

Pliers



(1)

Flashlight



(1)

Hammer Drill\*

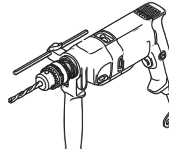

(1)

Safety Glasses



(1 for each person)

\*See “Screwdriver Notice” on page 7.

*Refer to the following areas throughout the instructions to assist in the assembly process:*

This area is located at the top, left-hand corner of the page and indicates which tools and hardware are needed to complete the assembly steps on a page.



**TOOLS AND HARDWARE REQUIRED FOR THIS PAGE**



This area is located at the top, right-hand corner of the page and shows an image of the product with shaded parts indicating which section is being assembled.

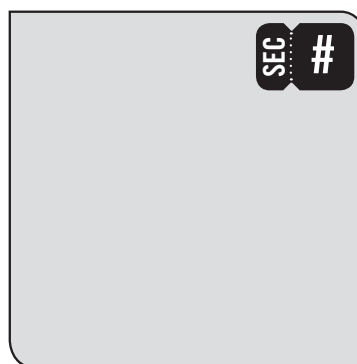

This area is usually located in the bottom, left-hand corner of a step and indicates that special attention is needed to perform a particular part of a step.



**Note:**

These areas are usually located in the bottom, right-hand corner of a step and indicate that damage to the product or serious injury may occur if the caution or warning is not heeded.



**CAUTION**



**WARNING**

Throughout the Parts & Hardware List, Part & Hardware Identifiers, and instructions are three-letter IDs. These IDs are below the images of the parts and hardware to help you locate and identify the parts and hardware during assembly. These IDs are not necessarily on the parts themselves.

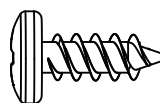

ADZ (x10)  
1/4" x 5/8" Pan-Head Screw

## IMPORTANT NOTICES

### Level Surface Notice:

Surface must be leveled before installation. We recommend building a level work space with a concrete or patio style surface. If the surface is not properly leveled, the Outdoor Shed will not assemble correctly. Proper surface leveling will save you time in the long run, so please do not ignore this step.

---

### Building Code Notice:

Consult all local building codes, as well as city and county ordinances, to ensure that the construction of the Outdoor Shed does not require a building permit. Proper building permit documentation may be required in your neighborhood, and it would be unfortunate to learn this after constructing the Shed.

---

### Screwdriver Notice:

You may use a #2 Phillips head screwdriver bit and a power screwdriver or drill, instead of a hand screwdriver. However, be aware that the plastic pieces of your Shed can be damaged by overtightening of screws. To avoid damage we strongly recommend the use of a low-powered power screwdriver or a drill that has an adjustable clutch that is set on a low torque setting. If neither is available, use a hand screwdriver. In any case use caution to avoid overtightening the screws.

---

### Floor Puncture Notice:

Sharp objects may damage your floor. If resting sharp, heavy objects on your Shed floor, place a block of wood between the sharp object and floor.

---

### CAUTION:

If more than six (6) inches of snow accumulate on the roof of the shed, carefully remove the snow to avoid possible roof collapse. While standing on the ground, remove the snow from the roof with a broom or snow shovel. Do not stand on the roof to remove snow.

# PARTS & HARDWARE LIST

## BOX 1

ID	Description	Qty
AGR	Outer Floor Panel	2
AFX	Center Floor Panel	2
AGH	Side Gable 1	2
AGI	Side Gable 2	2
AGQ	Roof Panel	4
AHB	Roof Panel for Skylight	2
AFY	Center Roof Cap	3
BDK	Right Shed Door	1
BDJ	Left Shed Door	1
BDS	Lower Right, Front Gable Roof Panel	1
BDR	Lower Left, Front Gable Roof Panel	1
BDU	Upper Right, Front Gable Roof Panel	1
BDT	Upper Left, Front Gable Roof Panel	1
BDW	Entry Gable Roof Cap	1
BDC	Entry Gable	1
AVF	90" Shelf	2

### CKP METAL PARTS KIT 1

AFH	Truss Gutter Channel	3
AFC	Door End Channel	2
BDD	Entry Header Bar	1
AFG	Roof Truss Brace	3
AFM	Wall/Shelf Support Channel	6
CRE	Door Hinge Tube	2

### CKQ METAL PARTS KIT 2

BDQ	Center Truss Channel	1
BDP	Right Truss Channel	1
BDO	Left Truss Channel	1

## BOX 2

AGW	Corner Wall Panel 106	2
AGL	Corner Wall Panel 107	2
AHD	Wall Panel	6
AHH	Window Wall Panel	1
BDI	Right Half-Window Wall Panel	1
BDH	Left Half-Window Wall Panel	1
BDV	Half-Wall Window	2

### CQM SMALL PARTS KIT

AHC	Skylight	4
AFL	Roof Support Strip	8
AHE	Window	1
AGB	Domed Skylight	2
AGG	Left End Roof Cap	1
AFW	Right End Roof Cap	1
AQX	Truss Connector	3
AFZ	Corner Shelf	2

### BUH SMALL PARTS BOX

AIX	Wood Shim	4
AIW	Wood Block	1
AFU	Pegboard Strip	1

### BQH FLOOR ASSEMBLY HARDWARE

BQC	#8 x 1/2" Pan-Head Screw	20
AHO	Door Hinge Bushing	2
ADC	#2 Phillips Bit	1

### BEA TRUSS FRAME ASSEMBLY HARDWARE

ADJ	1/4" Cap Nut	18
ADY	#10 x 3/8" Pan-Head Screw	12
ADK	#10 Cap Nut	12
AQY	1/4" x 2" Phillips Truss Screw	12
ADH	1/4" Threaded Rod	3

### BEB WALL PANEL INSTALLATION HARDWARE

ADZ	1/4" x 5/8" Pan-Head Screw	85
-----	----------------------------	----

### BEC DOMED SKYLIGHT ASSEMBLY PARTS (x2)

ACR	#10 x 5/8" Carriage Bolt	12
AEE	#10 x 1/2" Flat Washer	12
ADK	#10 Cap Nut	12
AHI	6' 1/4" x 3/4" Butyl Tape	1

ID	Description	Qty
----	-------------	-----

### GABLE ASSEMBLY HARDWARE

#### BHV SIDE GABLE ASSEMBLY HARDWARE (x2)

AGP	Louvered Vent	1
AIQ	Vent Screen	1
ADW	#10 x 3/4" Pan-Head Screw	5
AEE	#10 x 1/2" Flat Washer	5
ADZ	1/4" x 5/8" Pan-Head Screw	4
AHS	End Plug (Not used)	2
ACB	#10 x 1 1/4" Pan-Head Screw (Not used)	1
ADV	1/4" x 1 1/8" Pan-Head Screw	6

#### BEE ENTRY GABLE ASSEMBLY HARDWARE

ADV	1/4" x 1 1/8" Pan Head Screw	4
AHS	End Plug	2

#### BEF LEFT DOOR ASSEMBLY HARDWARE

AHZ	Left Door Handle	1
AHM	Deadbolt Latch	2
ABU	1/4" x 1 1/2" Carriage Bolt	2
ADW	#10 x 3/4" Pan-Head Screw	3
AEE	#10 x 1/2" Flat Washer	3
ADJ	1/4" Cap Nut	2
AIA	Left Door Lock Bracket	1
AIB	Left Door Strike Plate	1

#### BEG RIGHT DOOR ASSEMBLY HARDWARE

AIK	Right Door Handle	1
ABV	1/4" x 2" Carriage Bolt	2
ADB	3/8" x 1/2" Steel Spacer	2
AAB	1/4" Centerlock Nut	2
AHY	Latch Spring	1
AHW	Latch Block	1
AIO	Thumb Lever	1
ADW	#10 x 3/4" Pan-Head Screw	4
AHX	Latch Cover Plate	1
AHV	Door Latch	1
AIL	Right Door Lock Bracket	1
AEB	1/4" Flat Washer	2
AEE	#10 x 1/2" Flat Washer	5

#### BEH GABLE, TRUSS, DOOR & ROOF INSTALLATION HARDWARE

ADZ	1/4" x 5/8" Pan-Head Screw	160
AED	#10 x 1" Fender Washer	24
AQZ	Entry Gable Bracket	2
ADX	#10 x 1/2" Pan-Head Screw	28
ARA	1/8" Drill Bit	1
AXX	Truss Hole Insert	4
AHP	Cotter Pin	2
AQY	1/4" x 2" Phillips Truss Screw	4
ADJ	1/4" Cap Nut	4
AJA	1/2" Foam Cube	2

#### SHELF INSTALLATION HARDWARE

##### BHH 90" SHELF INSTALLATION HARDWARE (x2)

ADZ	1/4" x 5/8" Pan-Head Screw	14
AIY	Shelf Support Bracket	2

##### BHI CORNER SHELF INSTALLATION HARDWARE (x2)

ADZ	1/4" x 5/8" Pan-Head Screw	4
-----	----------------------------	---

##### BEI WINDOW INSTALLATION HARDWARE

ADW	#10 x 3/4" Pan Head Screw	28
ADZ	1/4" x 5/8" Pan-Head Screw	4
AIS	Window Latch Bracket	2
ADY	#10 x 3/8" Pan-Head Screw	1

##### BHC PEGBOARD STRIP INSTALLATION HARDWARE

ADW	#10 x 3/4" Pan-Head Screw	10
-----	---------------------------	----

##### BHD HOOKS BAG

AIF	2" Double-Arm Hook	1
AIG	4" Double-Arm Hook	1
AIH	J-Hook	3
AII	L-Hook	3
AIJ	Toolholder	2

# PARTS IDENTIFIER

## BOX 1

Parts shown at 4% of actual size

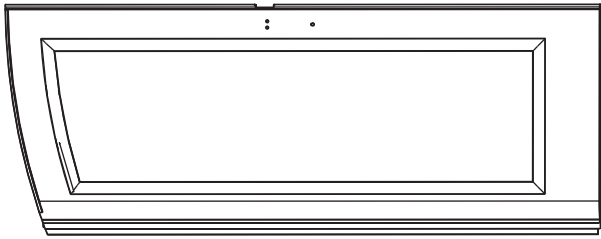

**BDJ** (x1)  
Left Shed Door

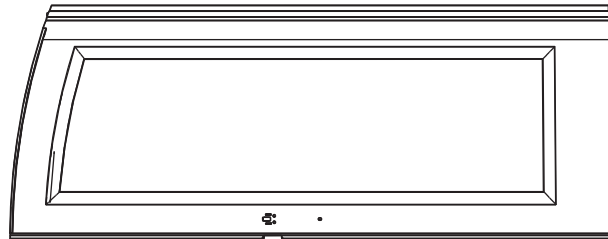

**BDK** (x1)  
Right Shed Door

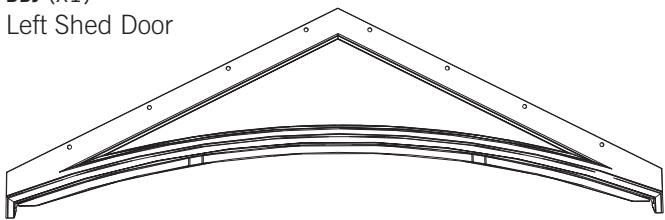

**BDC** (x1)  
Entry Gable

Rear View

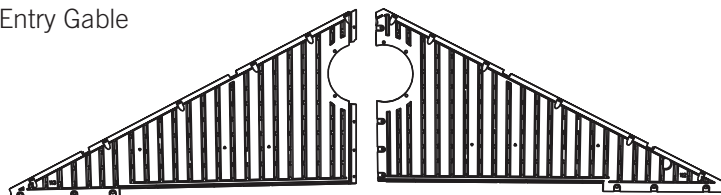

**AGH** (x2)  
Side Gable 1

Rear View

**AGI** (x2)  
Side Gable 2

Rear View

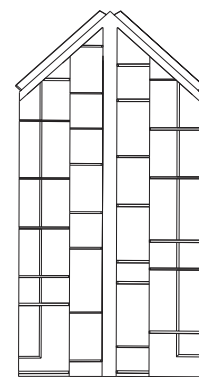

**BDW** (x1)  
Entry Gable Roof Cap

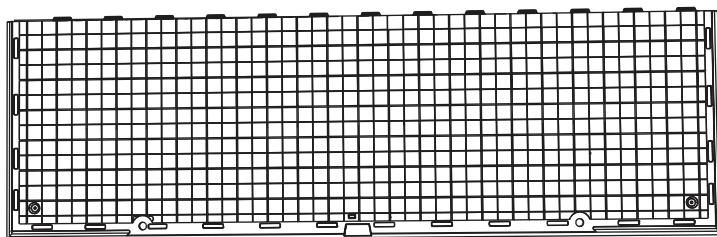

**AGR** (x2)  
Outer Floor Panel

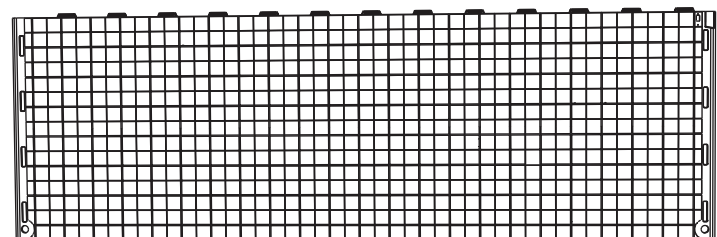

**AFX** (x2)  
Center Floor Panel

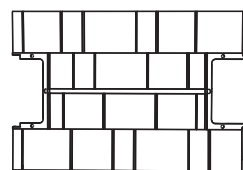

**AFY** (x3)  
Center Roof Cap

**!** *Note: Throughout the Parts & Hardware List, Part & Hardware Identifiers, and instructions are three-letter IDs. These IDs are below the images of the parts and hardware to help you locate and identify the parts and hardware during assembly. These IDs are not necessarily on the parts themselves.*

# PARTS IDENTIFIER

## BOX 1

Parts shown at 4% of actual size

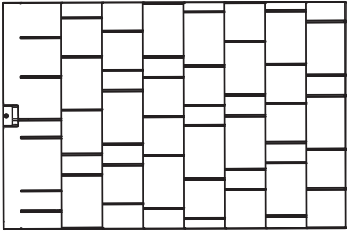

**AGQ** (x4)  
Roof Panel

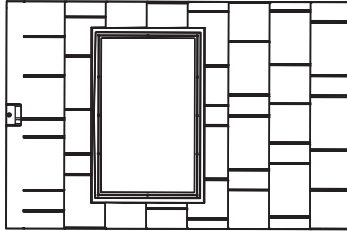

**AHB** (x2)  
Roof Panel for Skylight

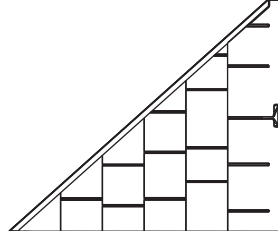

**BDT** (x1)  
Upper Left, Front Gable Roof Panel

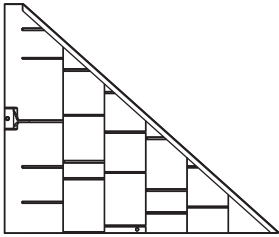

**BDU** (x1)  
Upper Right, Front Gable Roof Panel

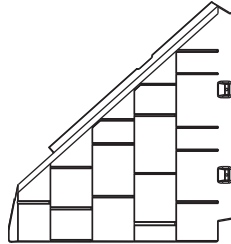

**BDR** (x1)  
Lower Left, Front Gable Roof Panel

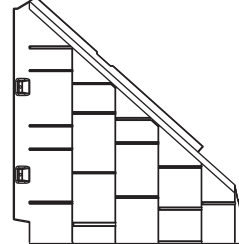

**BDS** (x1)  
Lower Right, Front Gable Roof Panel



**AVF** (x2)  
90" Shelf

## [CKP] METAL PARTS KIT 1

Parts shown at 8% of actual size

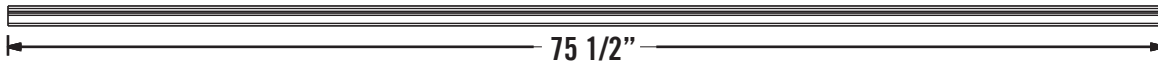

**\*AFC** (x2)  
Door End Channel

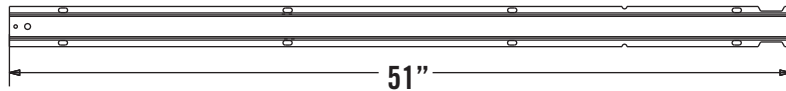

**\*AFH** (x3)  
Truss Gutter Channel



**\*BDD** (x1)  
Entry Gable Header Bar



**\*AFG** (x3)  
Roof Truss Brace

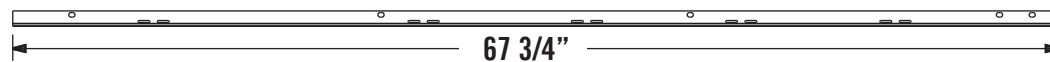

**\*AFM** (x6)  
Wall/Shelf Support Channel

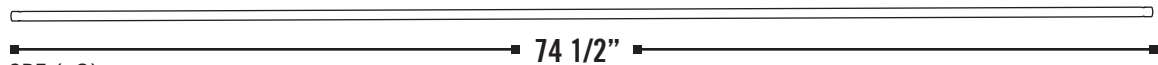

**CRE** (x2)  
Door Hinge Tube

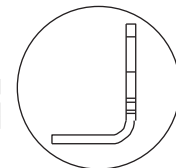
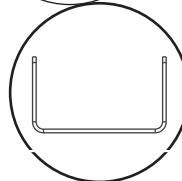
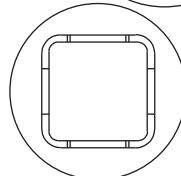
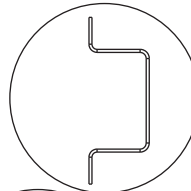
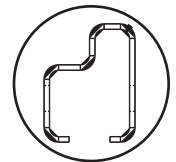

# PARTS IDENTIFIER

## BOX 1

### [CKQ] METAL PARTS KIT 2

Parts shown at 8% of actual size

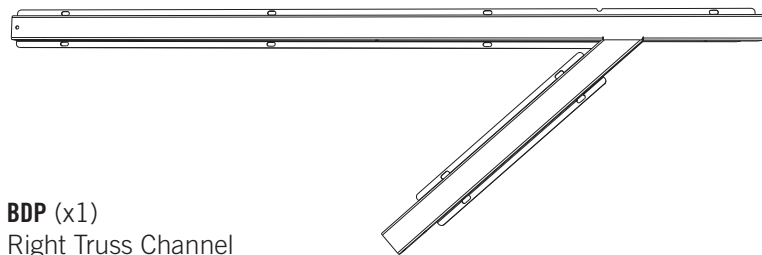

**BDP** (x1)  
Right Truss Channel

**BDO** (x1)  
Left Truss Channel

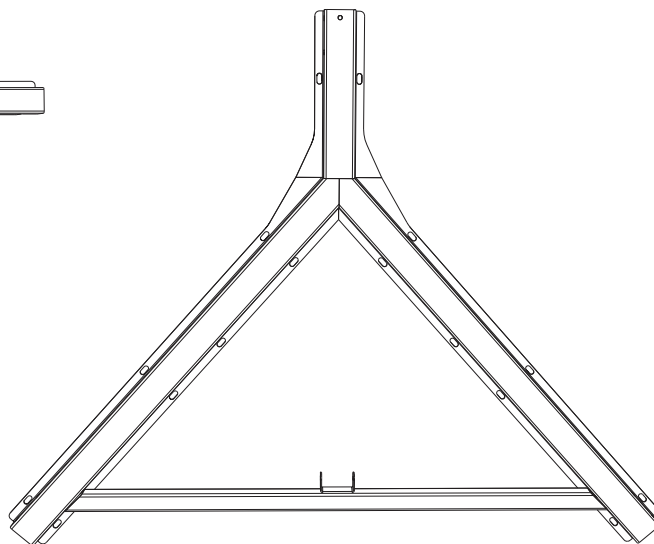

**BDQ** (x1)  
Center Truss Channel

## BOX 2

Parts are shown 4% of actual size

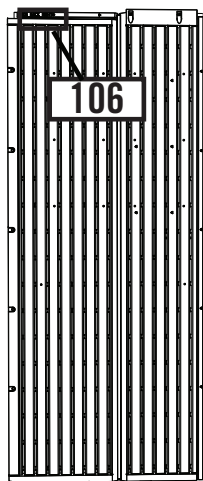

**AGW** (x2)  
Corner Wall Panel 106

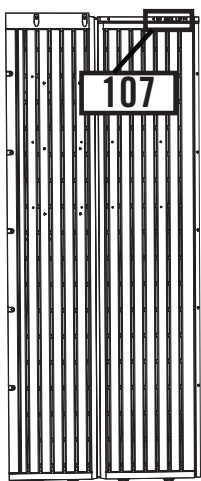

**AGL** (x2)  
Corner Wall Panel 107

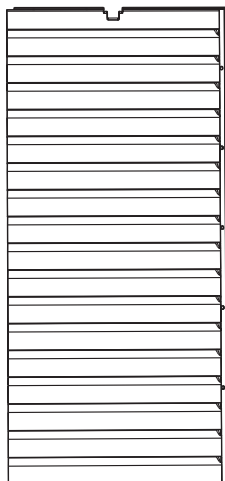

**AHD** (x6)  
Wall Panel



**AHH** (x1)  
Window Wall Panel

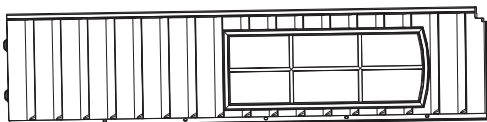

**BDI** (x1)  
Right Half-Window Wall Panel

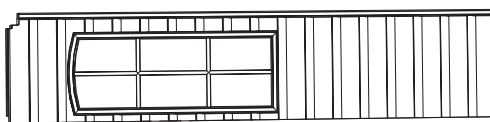

**BDH** (x1)  
Left Half-Window Wall Panel

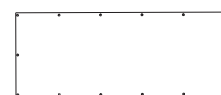

**BDV** (x2)  
Half-Wall Window



# PARTS & HARDWARE IDENTIFIER

## BOX 2

### [CQM] SMALL PARTS KIT

Parts shown at 4% of actual size

**115**

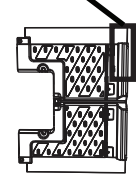

**AGG (x1)**  
Left End Roof Cap

**116**

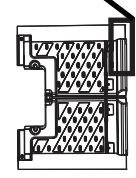

**AFW (x1)**  
Right End Roof Cap

Part shown at 8% of actual size

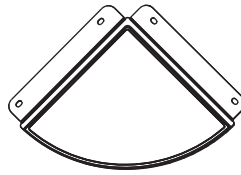

**AFZ (x2)**  
Corner Shelf

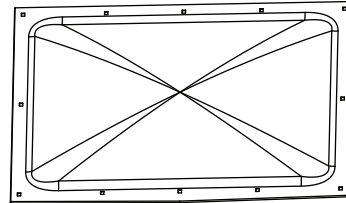

**AGB (x2)**  
Domed Skylight

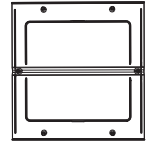

**AHC (x4)**  
Skylight

### [BUH] SMALL PARTS BOX

Parts are not shown to scale



**AIW (x1)**  
Wood Block



**AIX (x4)**  
Wood Shim

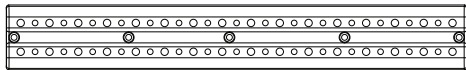

**AFU (x1)**  
Pegboard Strip

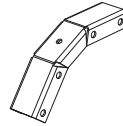

**AQX (x3)**  
Truss Connector



**AFL (x8)**  
Roof Support Strip

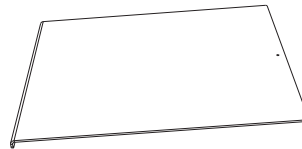

**AHE (x1)**  
Window

### [BEC] DOMED SKYLIGHT ASSEMBLY HARDWARE (x2)

Hardware shown at actual size (\*Unless otherwise noted)

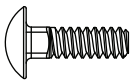

**ACR (x12)**  
#10 x 5/8" Carriage Bolt

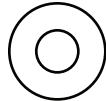

**AEE (x12)**  
#10 x 1/2" Flat Washer



**ADK (x12)**  
#10 Cap Nut



**\*AHI (x1)**  
Butyl Tape

### [BEA] TRUSS FRAME ASSEMBLY HARDWARE

Hardware shown at actual size (\*Unless otherwise noted)



**ADJ (x18)**  
1/4" Cap Nut



**ADK (x12)**  
#10 Cap Nut

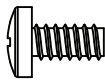

**ADY (x12)**  
#10 Flat-Head Screw

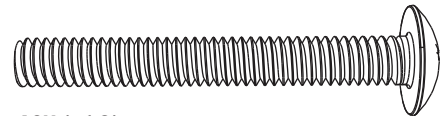

**AQY (x12)**  
1/4" x 2" Phillips Truss Screw

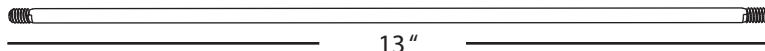

**\*ADH (x3)** 1/4" Threaded Rod

### [CRC] FLOOR ASSEMBLY HARDWARE

Hardware shown at actual size

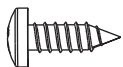

**BQC (x20)**  
#8 x 1/2" Pan-Head Screw (Only 12 used)



**ADC (x1)**  
#2 Phillips Bit

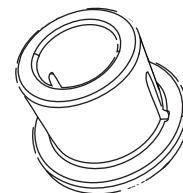

**AHO (x2)**  
Door Hinge Bushing

# PARTS & HARDWARE IDENTIFIER

## BOX 2

### [BEB] WALL PANEL INSTALLATION HARDWARE

Hardware shown at actual size

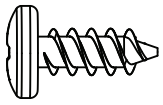

**ADZ (x85)**  
1/4" x 5/8" Pan-Head Screw

### [BHV] SIDE GABLE ASSEMBLY HARDWARE (x2)

Hardware shown at actual size (\*Unless otherwise noted)

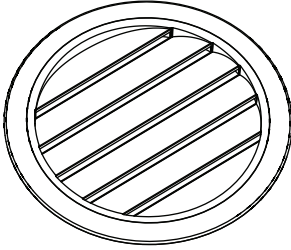

**\*AGP (x1)**  
Louvered Vent

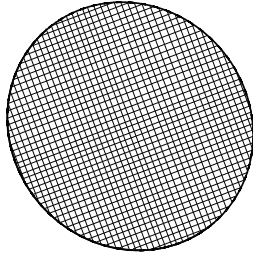

**\*AIQ (x1)**  
Vent Screen

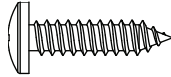

**ADW (x5)**  
#10 x 3/4" Pan-Head Screw

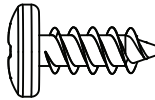

**ADZ (x4)**  
1/4" x 5/8" Pan-Head Screw

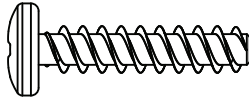

**ADV (x6)**  
1/4" x 1 1/8" Pan-Head Screw

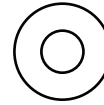

**AEE (x5)**  
#10 x 1/2" Flat Washer

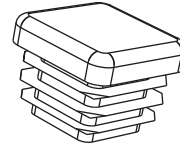

**AHS (x2)**  
End Plug

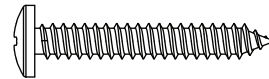

**ACB (x1)**  
#10 x 1 1/4" Pan-Head Screw

### [BEE] ENTRY GABLE ASSEMBLY HARDWARE

Hardware shown at actual size (\*Unless otherwise noted)

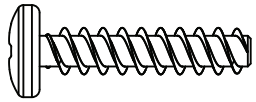

**ADV (x4)**  
1/4" x 1 1/8" Pan-Head Screw

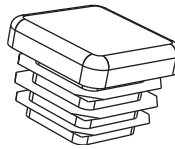

**AHS (x2)**  
End Plug

### [BHC] PEGBOARD STRIP INSTALLATION HARDWARE

Hardware shown at actual size



**ADW (x10)**  
#10 x 3/4" Pan-Head Screw  
(Not all screws are used)

### [BHD] Hooks Bag

Hardware shown at 50% of actual size

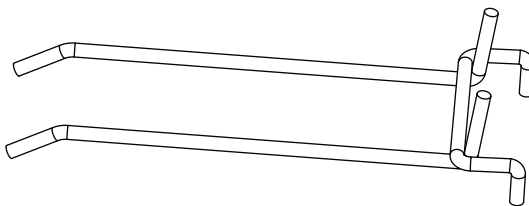

**AIG (x1)**  
4" Double-Arm Hook

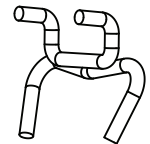

**AIJ (x2)**  
Toolholder

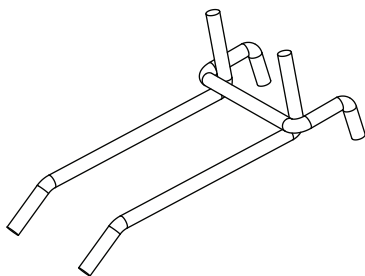

**AIF (x1)**  
2" Double-Arm Hook

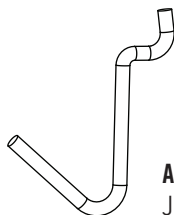

**AIH (x3)**  
J-Hook

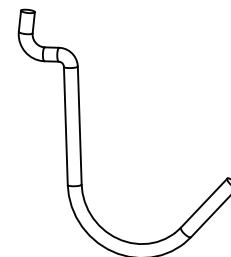

**AII (x3)**  
L-Hook

# PARTS & HARDWARE IDENTIFIER

## BOX 2

### [BEF] LEFT DOOR ASSEMBLY HARDWARE

Hardware shown at actual size (\*Unless otherwise noted)

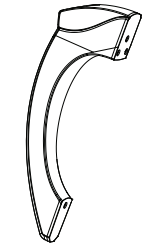

**\*AHZ (x1)**  
Left Door Handle

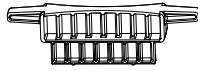

**\*AHM (x2)**  
Deadbolt Latch

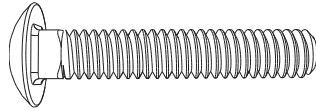

**ABU (x2)**  
1/4" x 1 1/2" Carriage Bolt

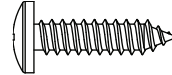

**ADW (x3)**  
#10 x 3/4" Pan-Head Screw

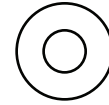

**AEE (x3)**  
#10 x 1/2" Flat Washer



**ADJ (x2)**  
1/4" Cap Nut



**\*AIA (x1)**  
Left Door Lock Bracket

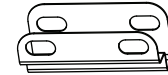

**\*AIB (x1)**  
Left Door Strike Plate

### [BEG] RIGHT DOOR ASSEMBLY HARDWARE

Hardware shown at actual size (\*Unless otherwise noted)

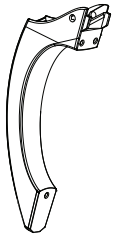

**\*AIK (x1)**  
Right Door Handle

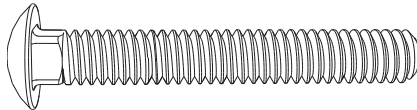

**ABV (x2)**  
1/4" x 2" Carriage Bolt

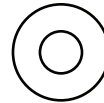

**AEE (x5)**  
#10 x 1/2" Flat Washer

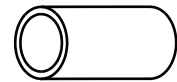

**ADB (x2)**  
3/8" x 1/2" Steel Spacer

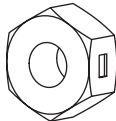

**AAB (x2)**  
1/4" Centerlock Nut

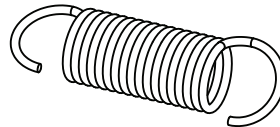

**AHY (x1)**  
Latch Spring

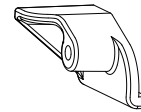

**\*AHW (x1)**  
Latch Block

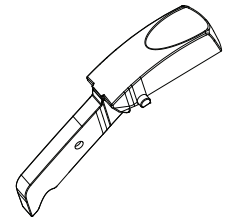

**\*AIO (x1)**  
Thumb Lever

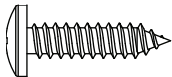

**ADW (x4)**  
#10 x 3/4" Pan-Head Screw

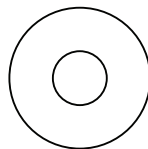

**AEB (x2)**  
1/4" Flat Washer



**\*AHX (x1)**  
Latch Cover Plate

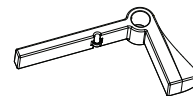

**\*AHV (x1)**  
Door Latch

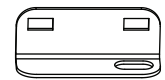

**\*AIL (x1)**  
Right Door Lock Bracket

### SHELF INSTALLATION HARDWARE

Hardware shown at actual size (\*Unless otherwise noted)

#### [BHH] 90" Shelf Installation Hardware (x2)

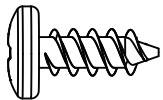

**ADZ (x14)**  
1/4" x 5/8" Pan-Head Screw



**\*AIY (x2)**  
10" Shelf Bracket

#### [BHI] Corner Shelf Installation Hardware (x2)

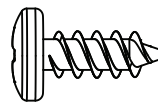

**ADZ (x4)**  
1/4" x 5/8" Pan-Head Screw

## PARTS & HARDWARE IDENTIFIER

### BOX 2

#### [BEH] GABLE, TRUSS, DOOR, & ROOF INSTALLATION HARDWARE

Hardware shown at actual size (\*Unless otherwise noted)

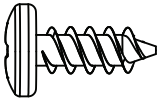

**ADZ** (x160)  
1/4" x 5/8" Pan-Head Screw

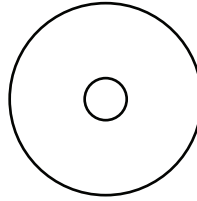

**AED** (x24)  
#10 x 1" Fender Washer

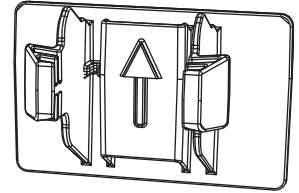

**\*AXX** (x4)  
Truss Hole Insert

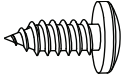

**ADX** (x28)  
#10 x 1/2" Pan-Head Screw



**AHP** (x2)  
Cotter Pin



**ARA** (x1)  
1/8" Drill Bit

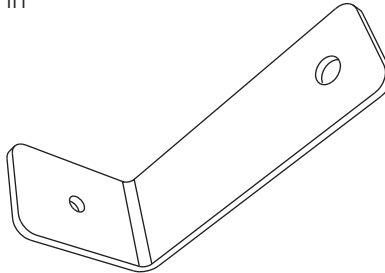

**\*AQZ** (x2)  
Entry Gable Bracket

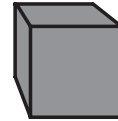

**AJA** (x2)  
Foam Cube

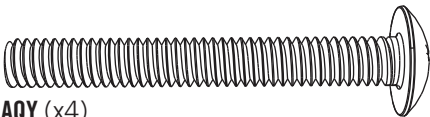

**AQY** (x4)  
1/4" x 2" Phillips Truss Screw



**ADJ** (x4)  
1/4" Cap Nut

#### WINDOW INSTALLATION HARDWARE

Hardware shown at actual size (\*Unless otherwise noted)

##### [BEI] Window Installation Hardware

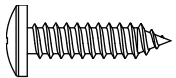

**ADW** (x28)  
#10 x 3/4" Pan-Head Screw

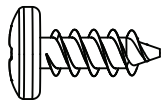

**ADZ** (x4)  
1/4" x 5/8" Pan-Head Screw

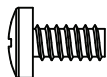

**ADY** (x1)  
#10 x 3/8" Pan-Head Screw

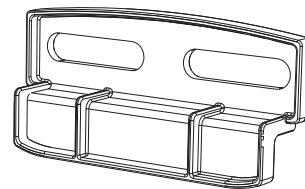

**\*AIS** (x2)  
Window Latch Bracket



## TOOLS AND HARDWARE REQUIRED FOR THIS PAGE

SEC 1



Concrete (1 cu. yd.)

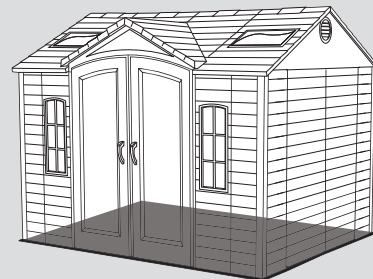

SEC

1.1

### SITE PREPARATION - CONCRETE PLATFORM PREPARATION

The actual dimensions of your shed (at its widest and longest points) are 8' x 10'. Ensure you select a site that will accommodate these measurements. The base of the shed is slightly smaller than this, so you will need to create a level surface that is at least 93 1/2" x 118 1/4". We recommend using a level cement or patio style surface. This will provide the best long-term performance for your shed.

**!** Note: Shed Extension Kits are available for this shed. Please consider possible shed expansion when planning the site for your shed. See back cover of this manual for information on ordering accessories.

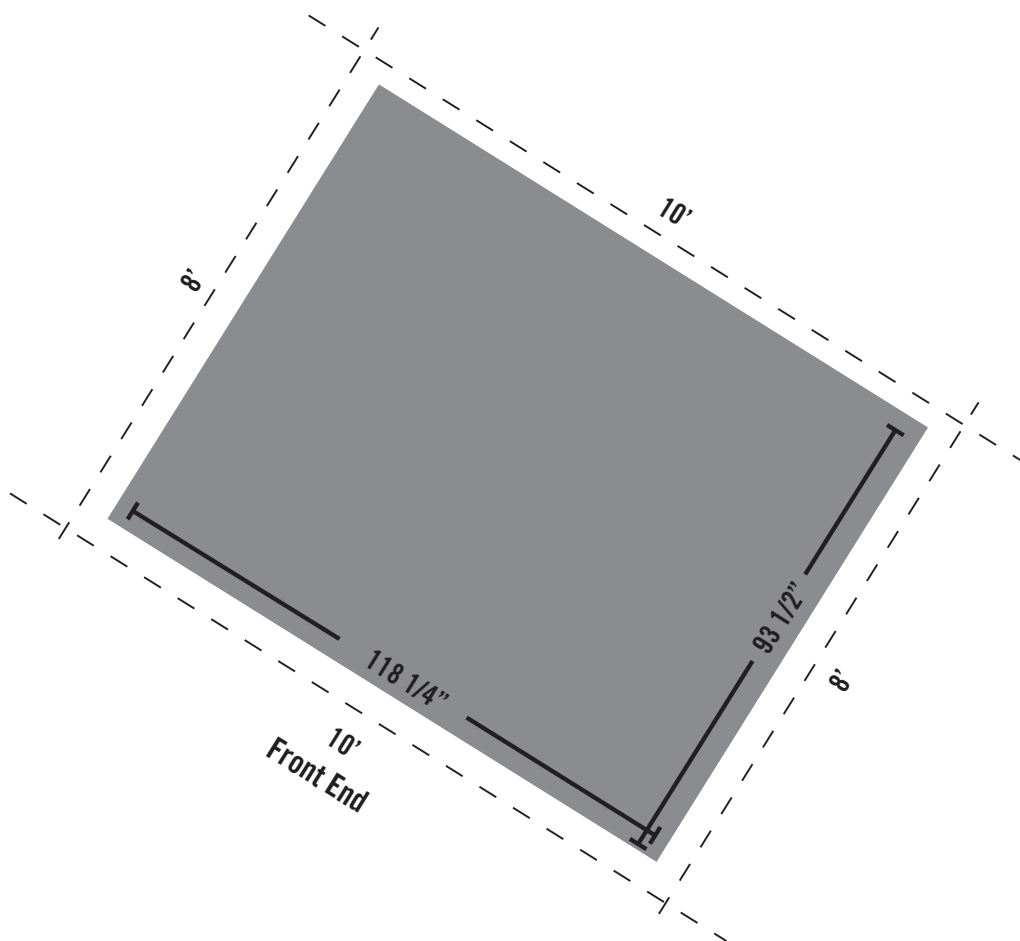

**!** Note: Surface must be leveled before installation. If the surface is not properly leveled, the Outdoor Shed will not assemble or function correctly. Proper surface leveling will save you time in the long run, so please do not ignore this step.

**!** Note: Any platform or similar structure should be built above ground in order to avoid water pooling inside the Shed.



## TOOLS AND HARDWARE REQUIRED FOR THIS PAGE

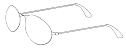

2" x 4" x 90 1/2" (x9) (Not included)



2" x 4" x 118 1/4" (x2) (Not included)

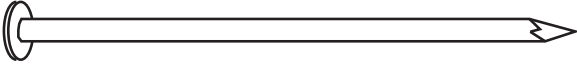

16d 3" Common Nail (x32) (Not included)

SEC 1

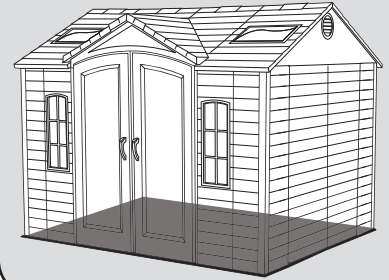

SEC

1.2

### ALTERNATIVE SITE PREPARATION: OPTION 1 - WOOD PLATFORM ASSEMBLY

Ensure all lumber used is treated and approved for outdoor use. Build outside frame to 93 1/2" x 118 1/4" outside dimensions:



*Note: Whenever possible, you should use the surfaces described on Page 7. When this is not possible, we recommend you use a wood platform or a filled wood frame.*

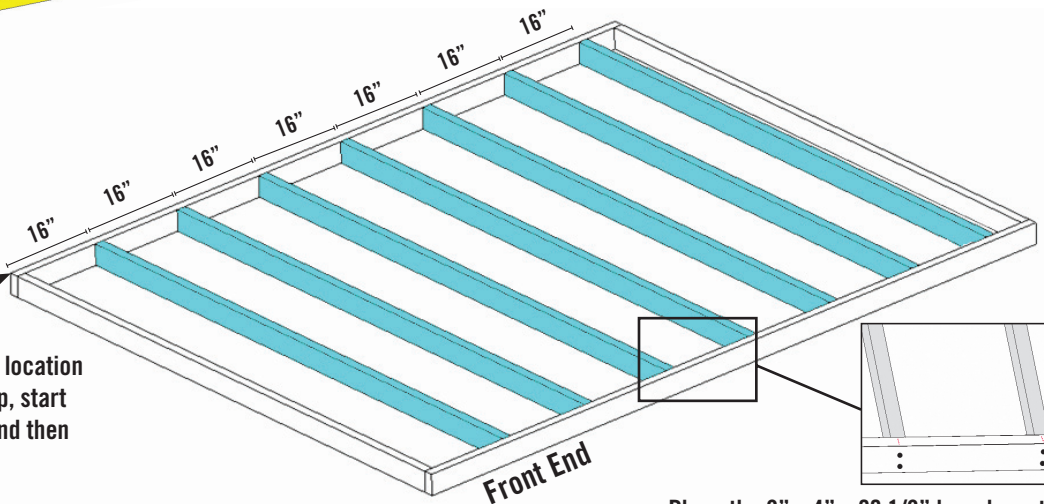
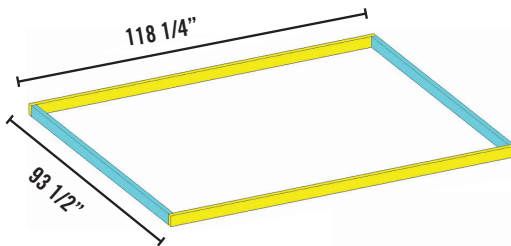

To ensure studs are in the correct location for nailing plywood in the next step, start measuring from the corner 16", and then measure from center to center.

Place the 2" x 4" x 90 1/2" boards on the inside of the frame. Nail each board in place with the 16d nails.



*Note: All lumber must be rated for outdoor use.*



*Note: Surface must be leveled before installation. If the surface is not properly leveled, the Outdoor Shed will not assemble or function correctly. Proper surface leveling will save you time in the long run, so please do not ignore this step.*



## TOOLS AND HARDWARE REQUIRED FOR THIS PAGE

SEC 1

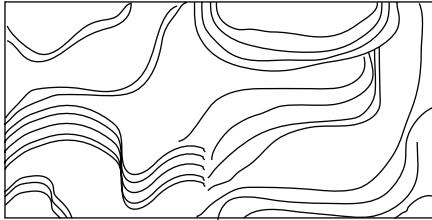

48" x 93 1/2" x 3/4" Treated Plywood (x2)  
(Not included)



22 1/4" x 93 1/2" x 3/4" Treated Plywood (x1)  
(Not included)

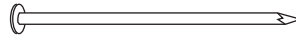

8d 1 1/2" Common Nail (x36)  
(Not included)

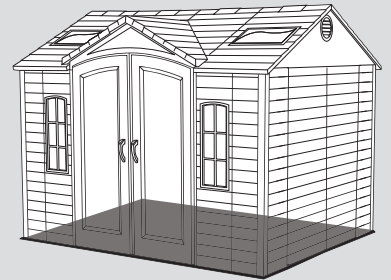

SEC

1.3

### ALTERNATIVE SITE PREPARATION: OPTION 1 - WOOD PLATFORM ASSEMBLY (CONT)

Square up the frame by measuring from corner to corner. Measurement A should equal Measurement B.

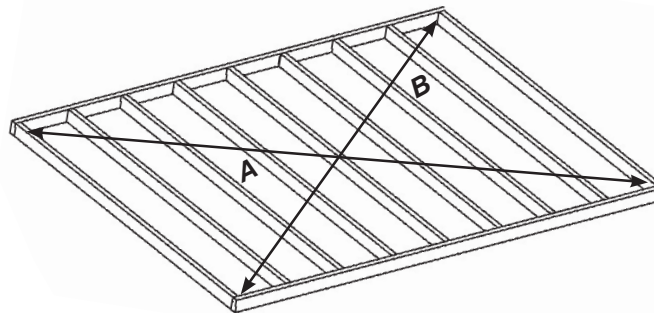

Note: All lumber must be rated for outdoor use.

SEC

1.4

Cut Plywood into sizes called for on previous page. Arrange the Plywood according to the diagram and nail into place with 8d x 1 1/2" nails. Place platform in the desired location. If platform does not rest level on the ground, build up low points with loose dirt until platform is stable. Drill three evenly spaced 1/2" drain holes in plywood between each 2" x 4" joist.

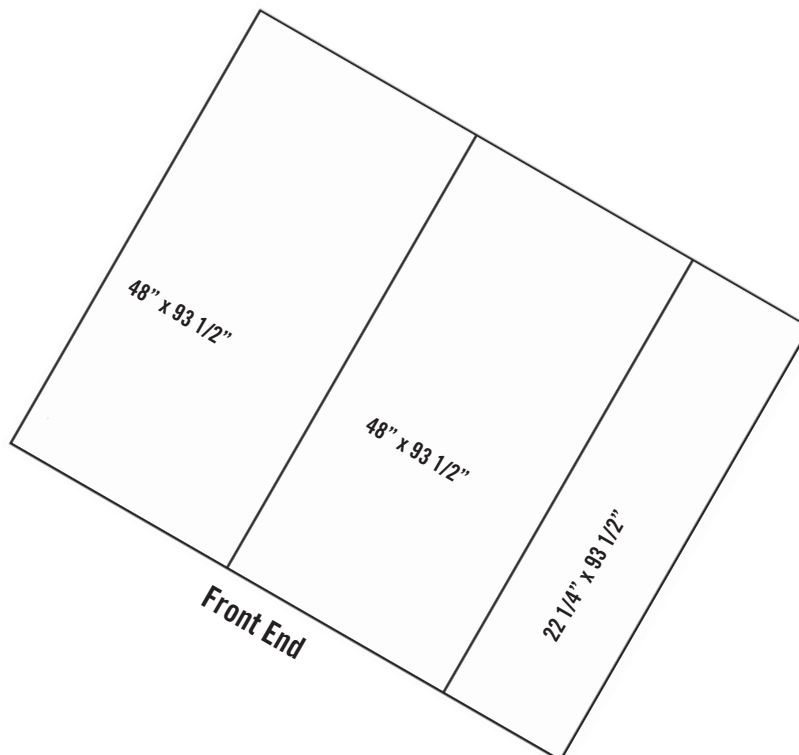





## TOOLS AND HARDWARE REQUIRED FOR THIS PAGE

SEC 1

2" x 4" x 120" (x2) (Not included)

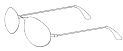

2" x 6" x 89" (x2) (Not included)

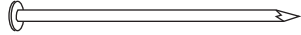

8d 1 1/2" Common Nail (x16)  
(Not included)



Pea Gravel (9.8 Cubic Feet) (Not included) L-Bracket (x4) (Not included)

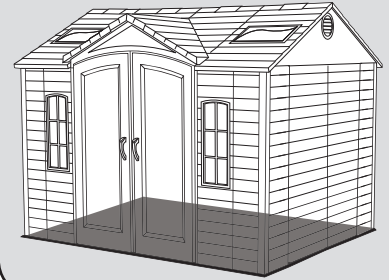

### ALTERNATIVE SITE PREPARATION: OPTION 2 - FILLED WOOD FRAME ASSEMBLY

SEC

1.5

Cut outside frame to 8' x 10' outside dimensions. Lay boards flat so widest parts face up. Ensure frame is level. Square up the frame by measuring from corner to corner. Measurement A should equal Measurement B. Nail an L-Bracket on each corner of the frame with 8d nails. Place platform in the desired location. If platform does not rest level on the ground, build up low points with loose dirt or "Pea" gravel, until platform is stable.



Note: Whenever possible you should use the surfaces described on Page 7.



Note: All lumber must be rated for outdoor use.

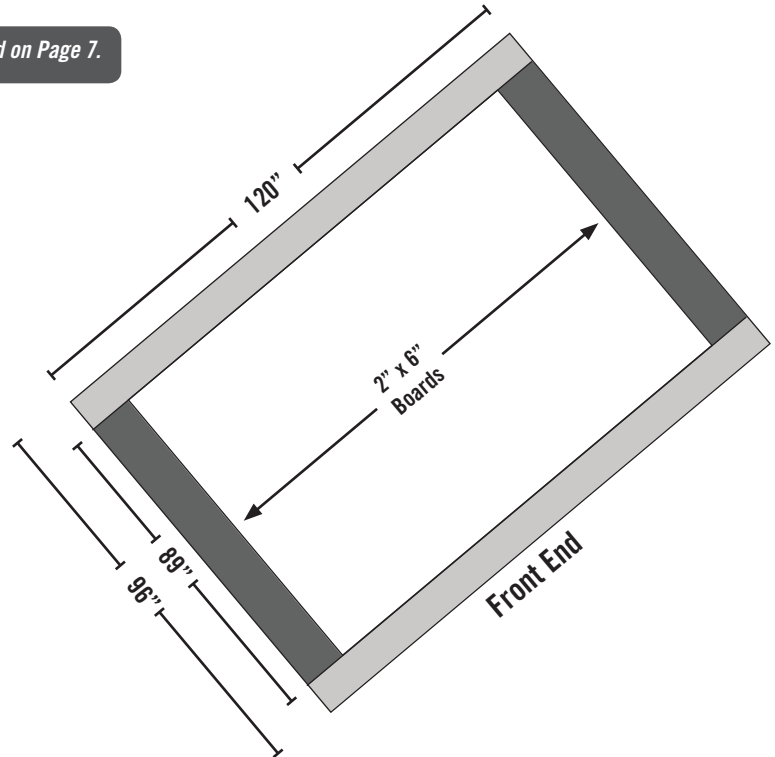
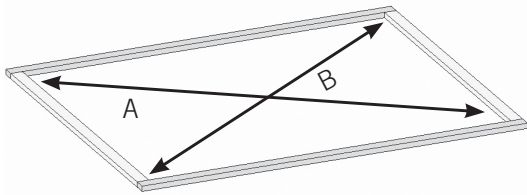

SEC

1.6

Once all boards are level and do not wobble, pack "Pea" gravel around the outside of the frame, and slope away from frame.

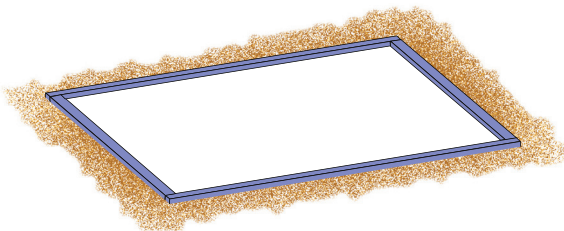

SEC

1.7

Now fill the inside of the frame with "Pea" gravel. Use a leveling board to scrape off extra fill material and to level the surface.

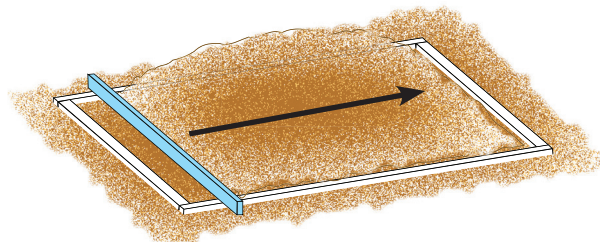

2" x 4" x 8' Leveling Board (x1)

## SEC 2 FLOOR ASSEMBLY

### HARDWARE REQUIRED

**HARDWARE BAG REQUIRED: BQH**

Part shown at actual size

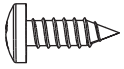

**BQC** (x20)  
#8 x 1/2" Pan-Head Screw  
(Only 12 used)

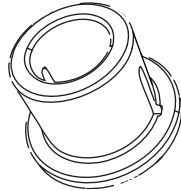

**AHO** (x2)  
Door Hinge Bushing



**ADC** (x1)  
#2 Phillips Bit

### PLASTIC PARTS REQUIRED

Parts shown at 4% of actual size

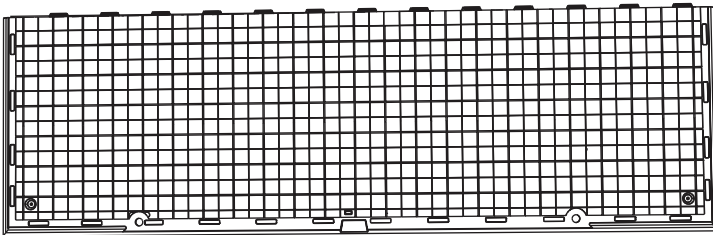

**AGR** (x2)  
Outer Floor Panel

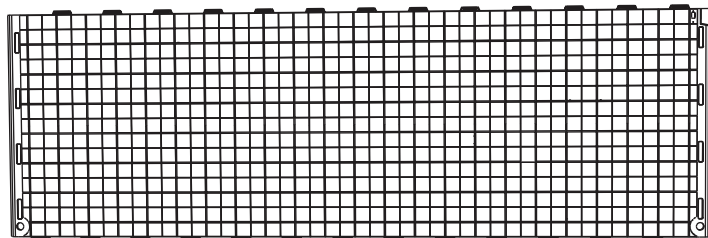

**AFX** (x2)  
Center Floor Panel

### TOOLS REQUIRED

**HARDWARE BAG REQUIRED: BQH**

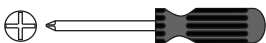

**Phillips Screwdriver**



**ADC** (x1)  
#2 Phillips Bit (Included)



**Safety Glasses**



## TOOLS AND HARDWARE REQUIRED FOR THIS PAGE

SEC 2



NO HARDWARE REQUIRED FOR THIS STEP

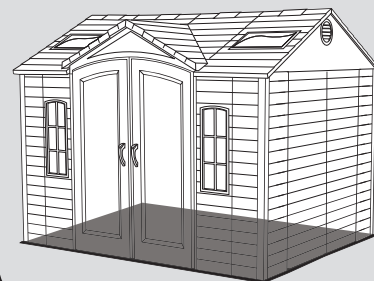

SEC

### FLOOR ASSEMBLY

2.1

Lay an **Outer Floor Panel (AGR)** flat on the ground. Hold a **Center Floor Panel (AFX)** at an angle as shown and fit tabs into slots. Lay Center Floor Panel flat.

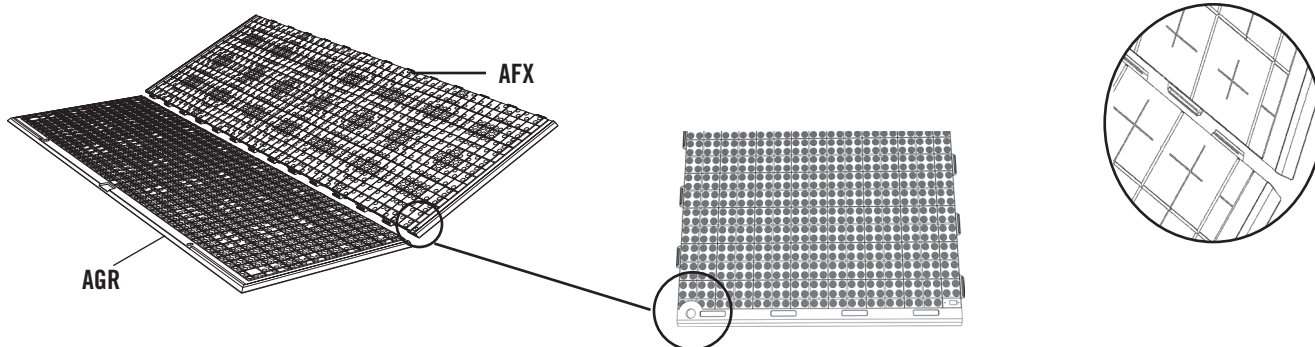

*Note: Ensure you insert the Inner Floor Panel (AFX) with the Door Hinge Bushing Holes toward the outside. You'll place the Doors here later.*

SEC

2.2

Hold the second **Center Floor Panel (AFX)** at an angle as shown and fit tabs into slots. Lay Center Floor Panel flat.

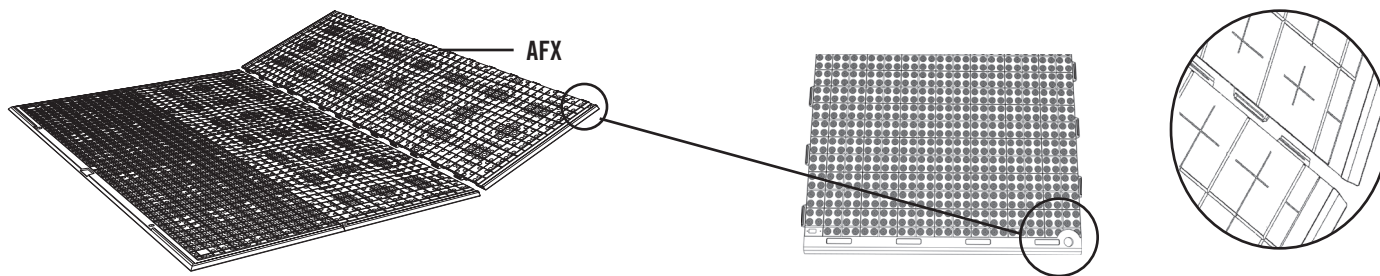

*Note: Ensure you insert the Inner Floor Panel (AFX) with the Door Hinge Bushing Holes toward the outside. You'll place the Doors here later.*



### CAUTION

Sharp objects may damage your floor. If resting sharp, heavy objects on your shed floor, place a block of wood between the sharp object and floor.



**TOOLS AND HARDWARE REQUIRED FOR THIS PAGE**

**SEC 2**

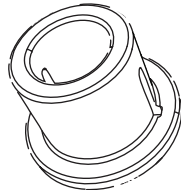

**AHO (x2)**

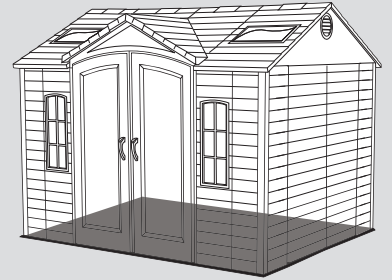

**SEC**

**2.3**

Finally, connect the last **Outer Floor Panel (AGR)** to the Center Floor Panel and lay flat.

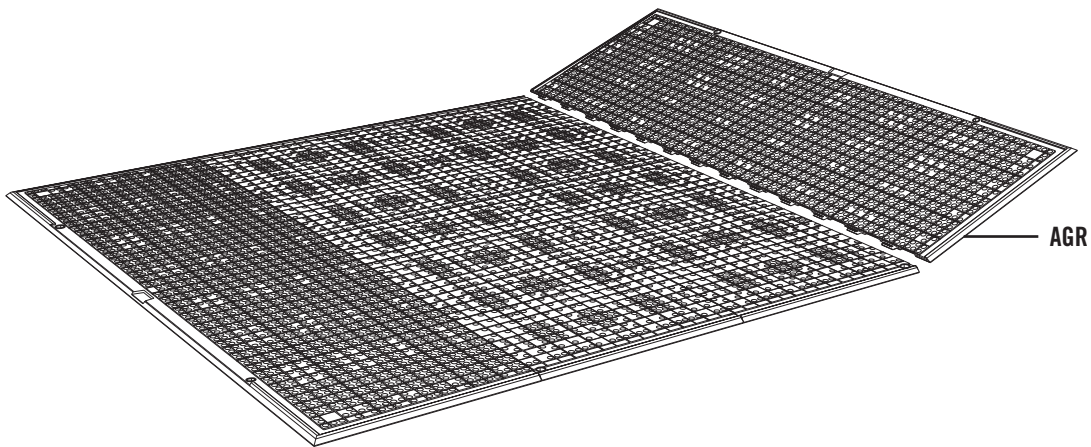

**AGR**

**SEC**

**2.4**

Lift the Floor Panels up enough to slide the two (2) **Door Hinge Bushings (AHO)** under and up through the holes in the Floor Panels as shown.

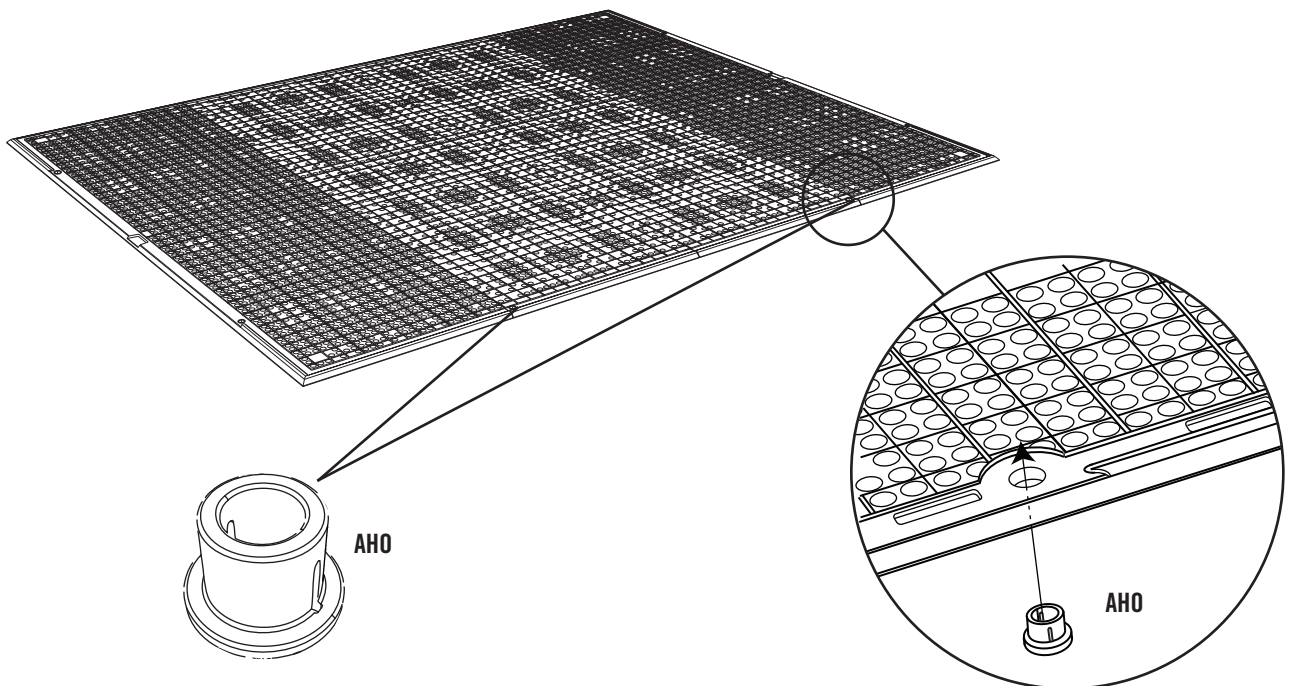

**AHO**

**AHO**





# TOOLS AND HARDWARE REQUIRED FOR THIS PAGE

SEC 2

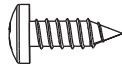

**BQC** (x20)  
(Only 12 used)

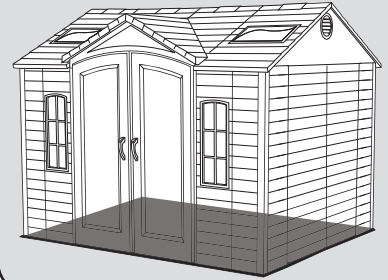

SEC

2.5

Face the seam of two adjacent Floor Panels. Insert two (2) **#8 x 1/2" Pan-Head Screws (BQC)** near the seam of a Floor Panel and down into the tab of the adjacent Floor Panel at the locations shown. Repeat this step for both sides of each seam in the Floor.

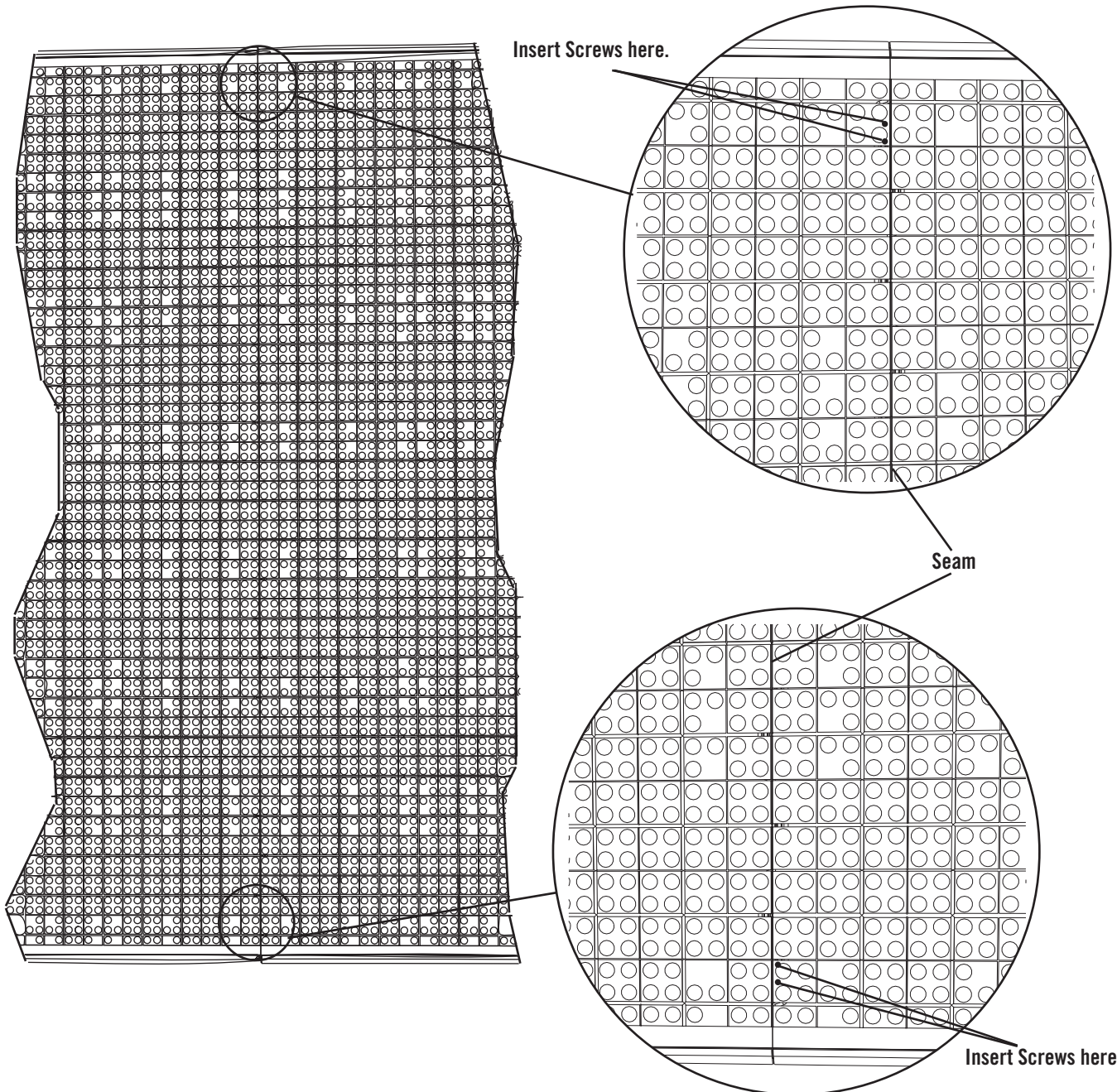



## TOOLS AND HARDWARE REQUIRED FOR THIS PAGE

SEC 2



**IF YOU PLAN ON ANCHORING YOUR SHED, CHECK WITH YOUR LOCAL HARDWARE STORE FOR SUITABLE HARDWARE.**

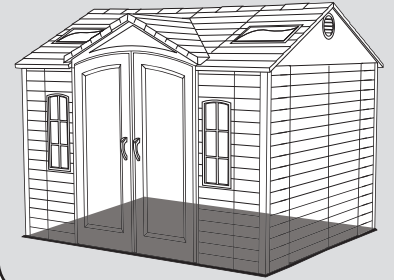

SEC

2.6

### ANCHORING THE SHED

If you plan on anchoring your shed, you can anchor it to your platform through the four indentations near the corners of the floor. The anchoring hardware used depends on the platform. If you have a concrete platform, we recommend using four (4) 3/8" Anchor Bolts and four (4) 3/8" x 1" Flat Washers. If you have a wood framed platform, we recommend using four (4) 3/8" Lag Bolts and four (4) 3/8" x 1" Flat Washers. Do not exceed a 3/8" diameter bolt. Refer to your local hardware store for this hardware. **Do not tighten the anchoring hardware until instructed to do so at the end of these instructions.**

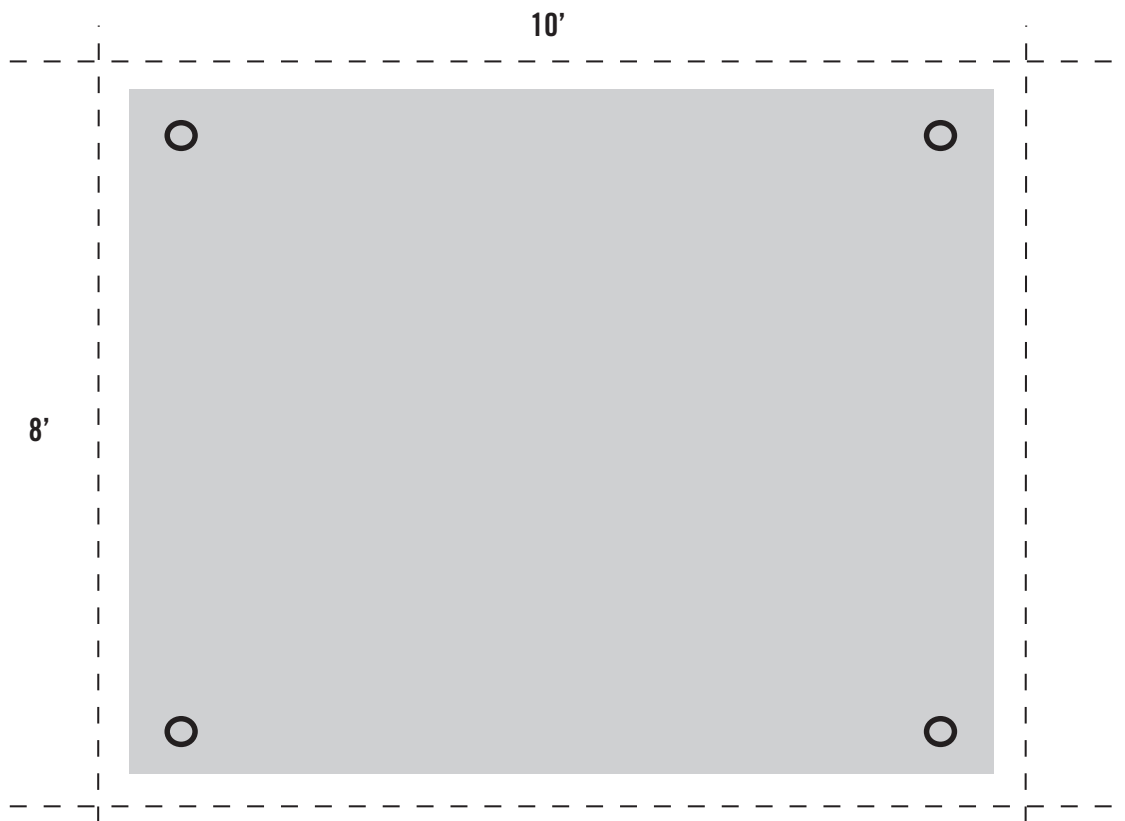

### WARNING

Failure to anchor the shed may result in property damage and/or personal injury.

# SEC 3 TRUSS ASSEMBLY

## HARDWARE REQUIRED

## HARDWARE BAG REQUIRED: BEA

Hardware shown at actual size (\*Unless indicated otherwise)

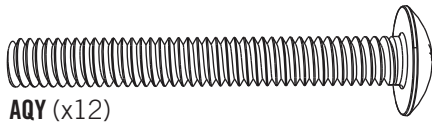

**AQY** (x12)  
1/4" x 2" Truss Screw

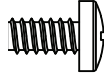

**ADY** (x12)  
#10 x 3/8" Screw



**ADJ** (x18)  
1/4" Cap Nut

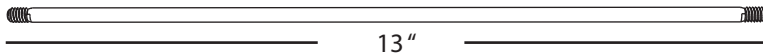

\***ADH** (x3) 1/4" Threaded Rod



**ADK** (x12)  
#10 Cap Nut

## METAL PARTS REQUIRED

## PARTS & METAL KITS REQUIRED: CKP, CKQ, CQM

Parts shown at 8% of actual size (\*Unless indicated otherwise)

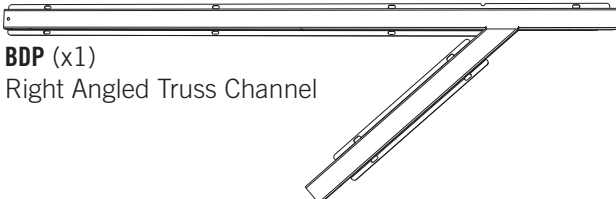

**BDP** (x1)  
Right Angled Truss Channel

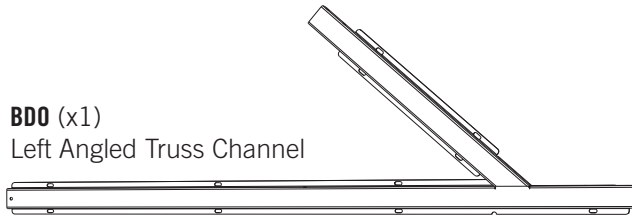

**BDO** (x1)  
Left Angled Truss Channel

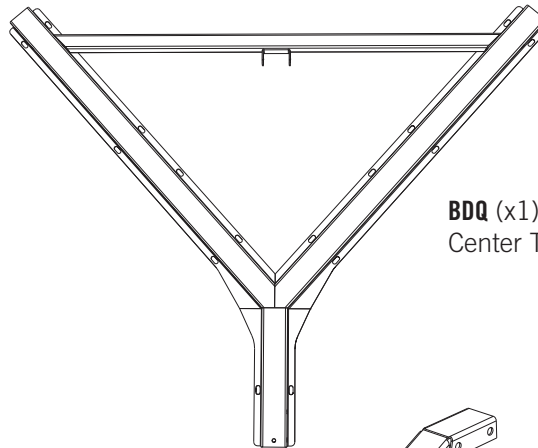

**BDQ** (x1)  
Center Truss Channel

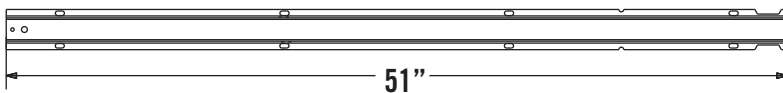

**AFH** (x3)  
Truss Gutter Channel

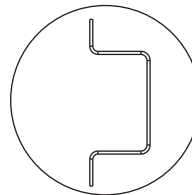

**AQX** (x3)\*  
Truss Connector



**AFG** (x3)  
Roof Truss Brace (Not to Scale)

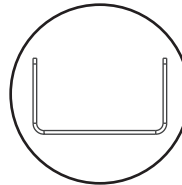

## TOOLS REQUIRED

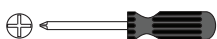

Phillips Screwdriver



7/16" Wrench (x2)



3/8" Wrench



Safety Glasses





## TOOLS AND HARDWARE REQUIRED FOR THIS PAGE

SEC 3



7/16"

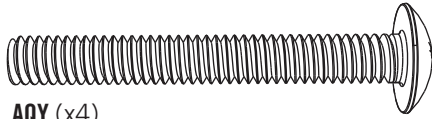

AQY (x4)



ADJ (x4)

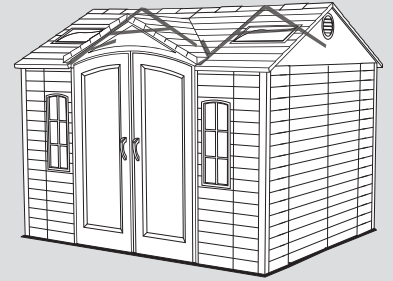

SEC

### SIDE ANGLED TRUSS ASSEMBLY

3.1

Stand the **Left Angled Truss Channel (BDO)** upright and set a **Truss Connector (AQX)** inside the end of the Left Angled Truss Channel as shown. Align the holes and secure with two (2) **1/4" x 2" Phillips Truss Screws (AQY)** and two (2) **1/4" Cap Nuts (ADJ)**.

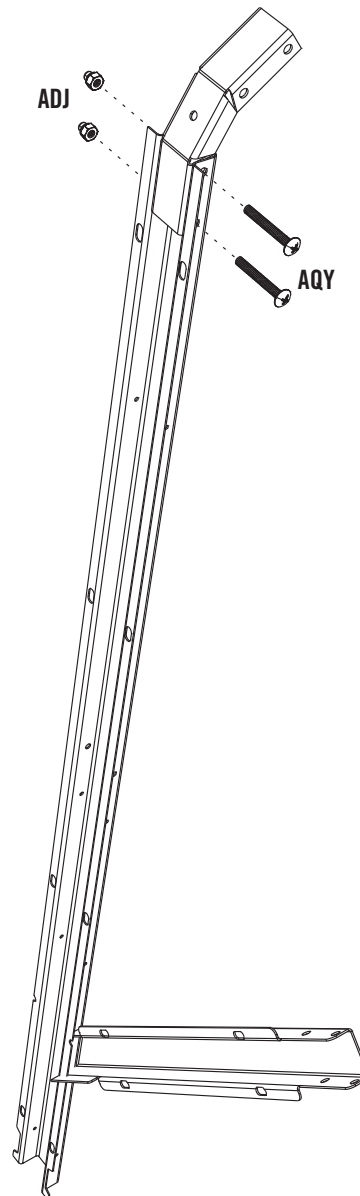
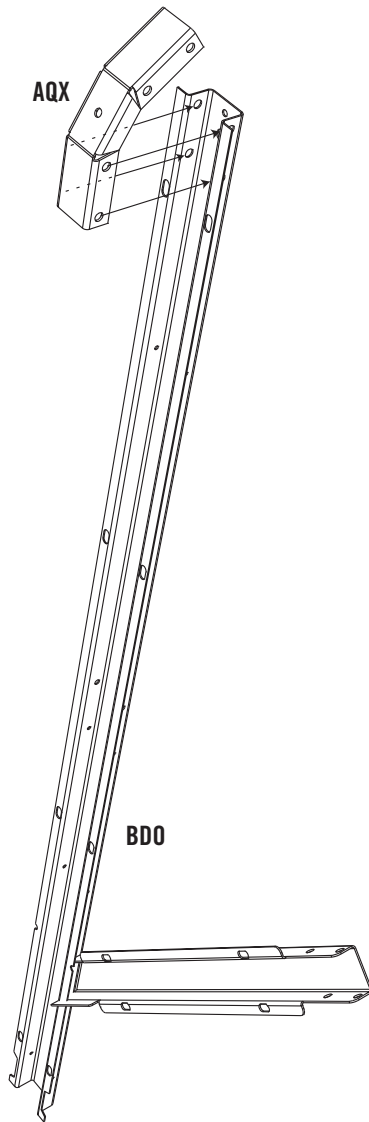



# TOOLS AND HARDWARE REQUIRED FOR THIS PAGE

SEC. 3



7/16"

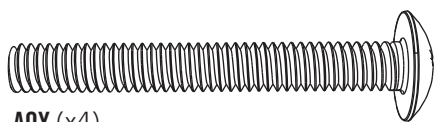

AQY (x4)



ADJ (x4)

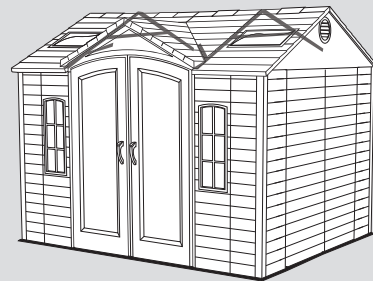

SEC

3.2

Connect a **Truss Gutter Channel (AFH)** to the Truss Connector using two (2) 1/4" x 2" Phillips Truss Screws (AQY) and two (2) 1/4" Cap Nuts (ADJ).

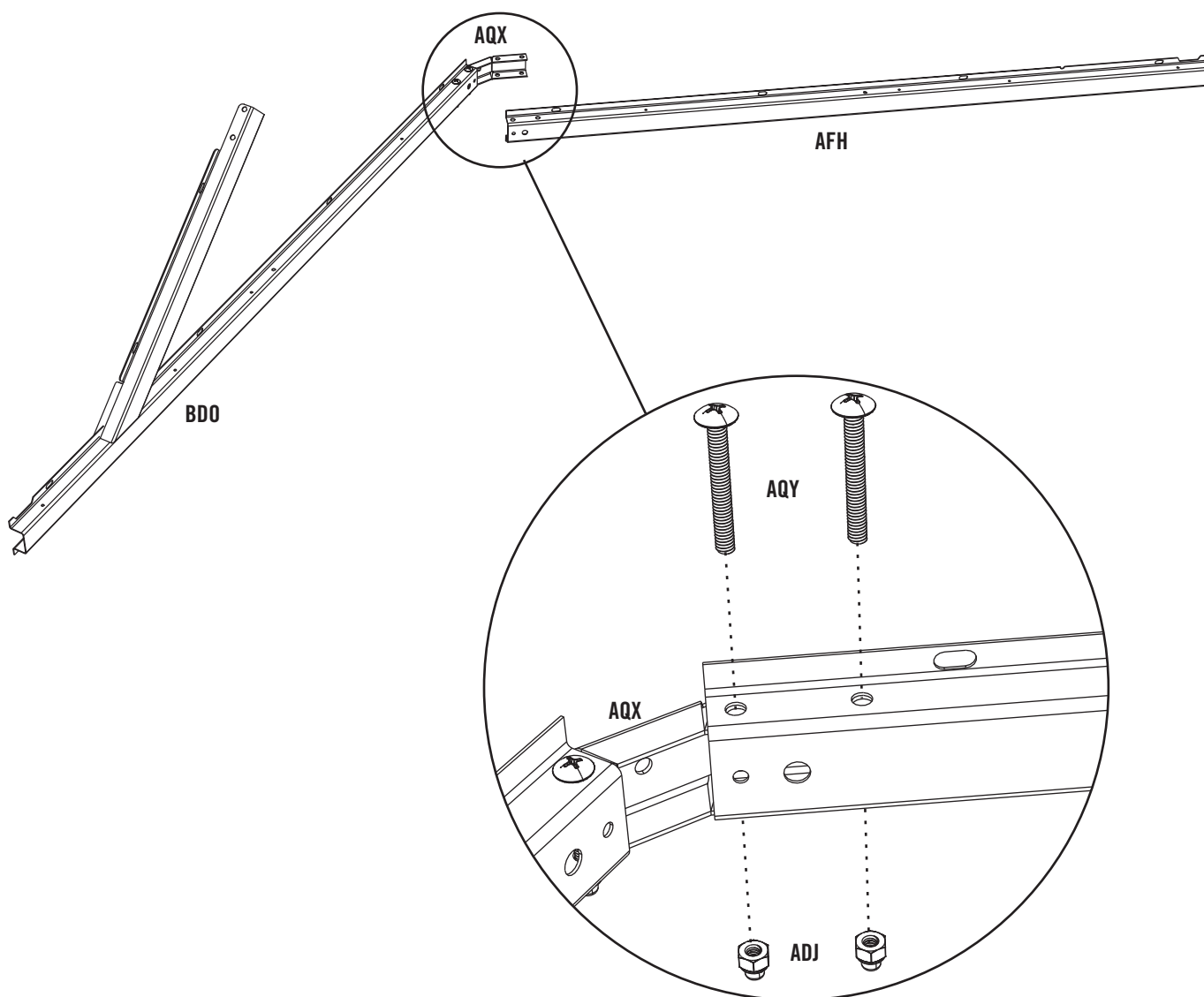



## TOOLS AND HARDWARE REQUIRED FOR THIS PAGE

SEC 3



3/8"

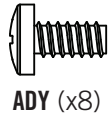

ADY (x8)



ADK (x8)

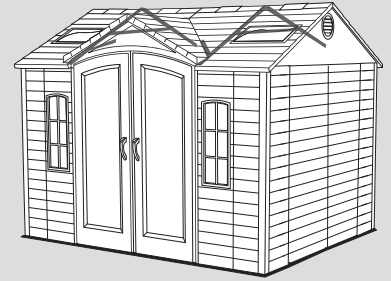

SEC

3.3

With the Angled Truss Assembly on its side, align the holes in a **Roof Truss Brace (AFG)** with those circled in the Left Angled Truss Channel and Truss Gutter Channel as shown.

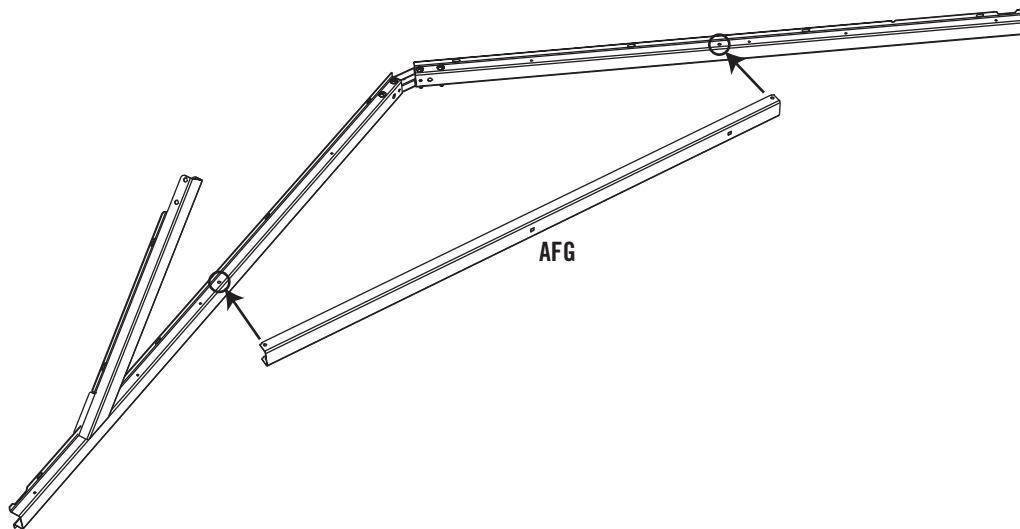

SEC

3.4

Secure the Roof Truss Brace to the Left Angled Truss Channel using two (2) **#10 x 3/8" Pan-Head Screws (ADY)** and two (2) **#10 Cap Nuts (ADK)**. Repeat this step for the other end of the Roof Truss Brace.

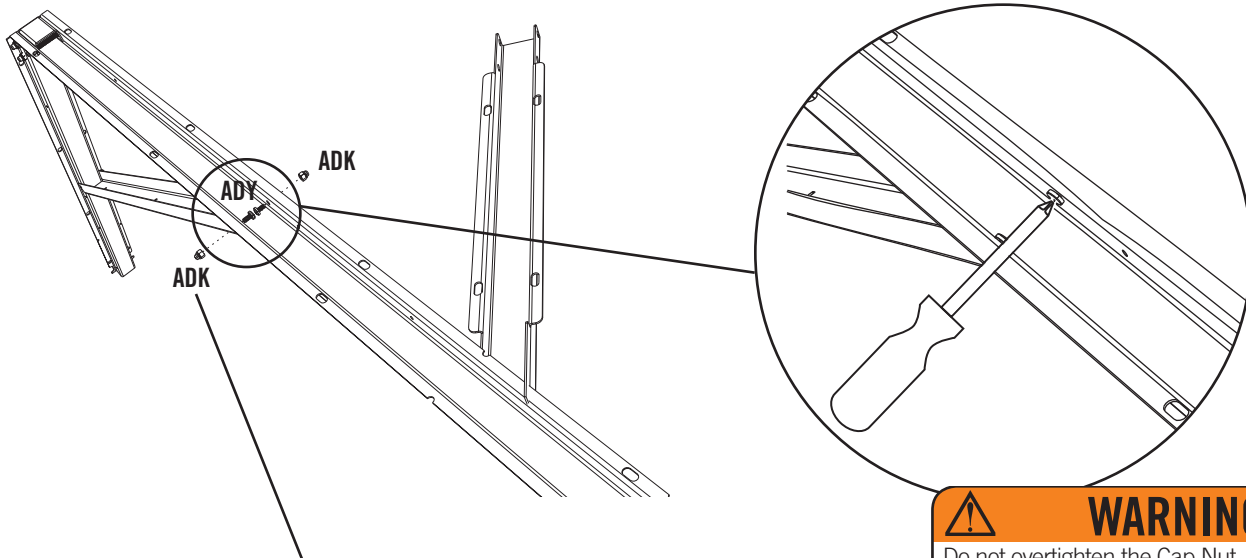

*Note: The Cap Nuts goes on the outside of the Truss.*



### WARNING

Do not overtighten the Cap Nut. If the end of the Bolt breaks through the plastic cap, call our Customer Service Department. Exposed threads on the end of the Bolt may cause serious injuries.



## TOOLS AND HARDWARE REQUIRED FOR THIS PAGE

SEC. 3

7/16" (x2)



ADJ (x4)

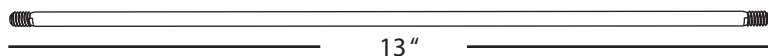

ADH (x2) (Not to scale)

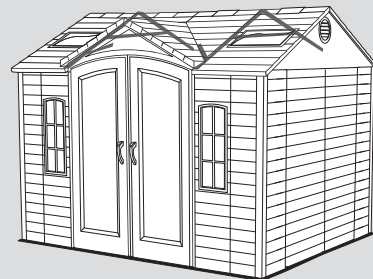

SEC

3.5

With the Angled Truss Assembly on its side, slide a **1/4" Threaded Rod (ADH)** through the Roof Truss Brace and the Truss Connector as shown. Secure the top and bottom of the 1/4" Threaded Rod with a **1/4" Cap Nut (ADJ)**. Tighten all hardware. The 1/4" Threaded Rod will still spin freely. Set aside. **Repeat previous steps for the Right Angled Truss Assembly.**

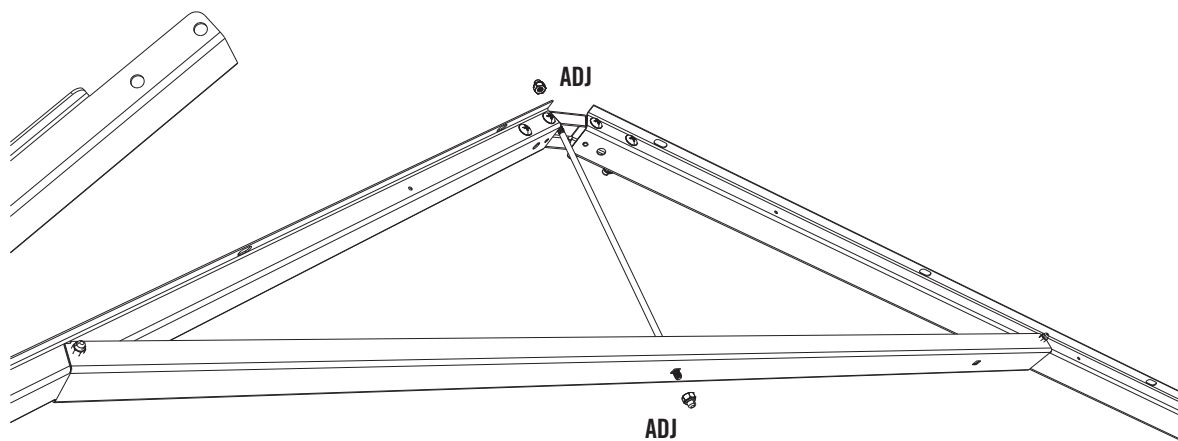
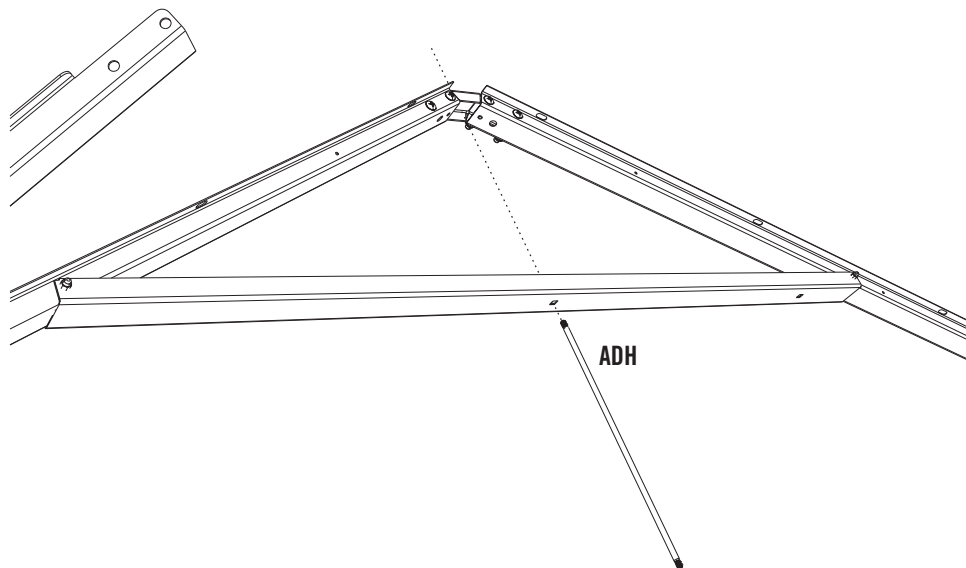

**WARNING**

Do not overtighten the Cap Nut.



# TOOLS AND HARDWARE REQUIRED FOR THIS PAGE

SEC 3



7/16"



ADJ (x4)



AQY (x4)

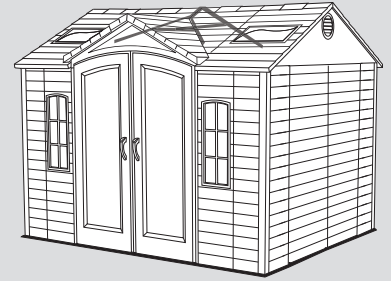

SEC

## CENTER ANGLED TRUSS ASSEMBLY

3.6

Attach a **Truss Connector (AQX)** to the **Center Angled Truss Channel (BDQ)** using the hardware shown.

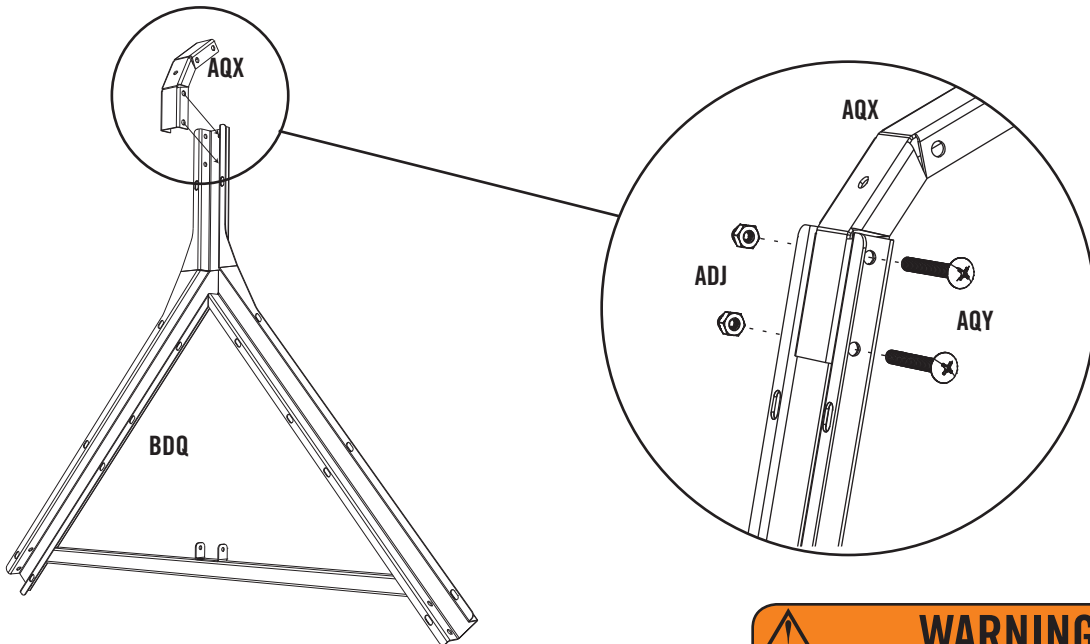

**WARNING**

Do not overtighten the Cap Nut.

SEC

Attach a **Truss Gutter Channel (AFH)** to the Truss Connector using the hardware shown.

3.7

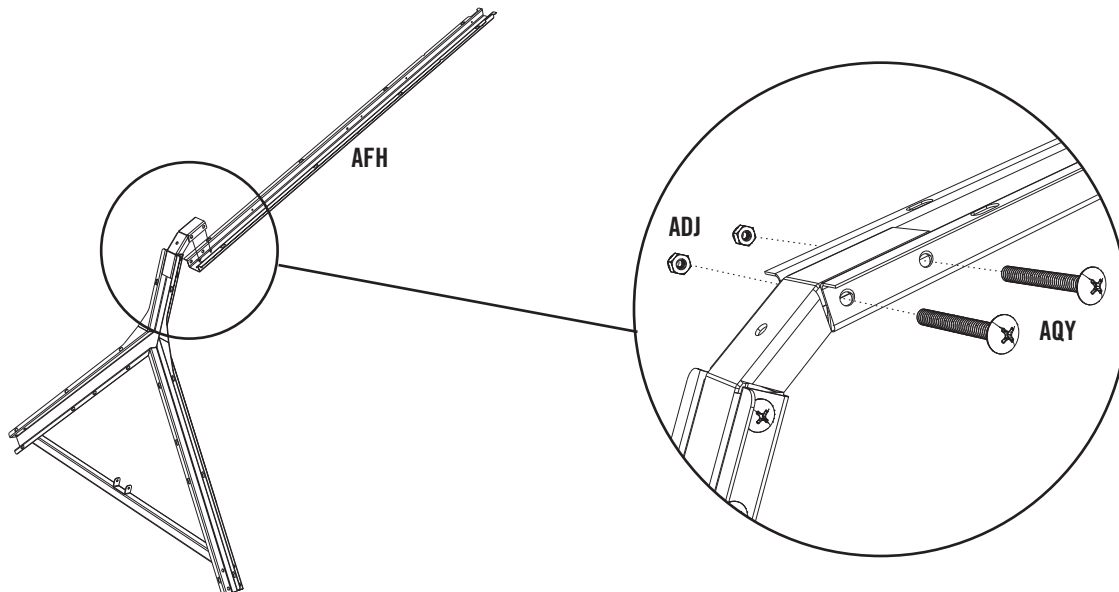



# TOOLS AND HARDWARE REQUIRED FOR THIS PAGE

SEC. 3



3/8"

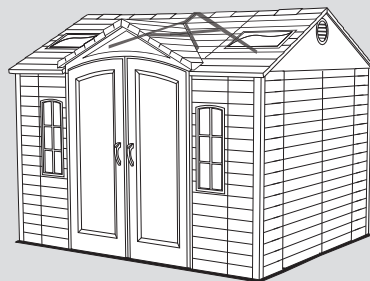

SEC

3.8

Align the hole in the Roof Truss Brace with that circled on the Truss Gutter Channel in the image below. Attach a **Roof Truss Brace (AFG)** to the Center Truss Assembly using the hardware shown.

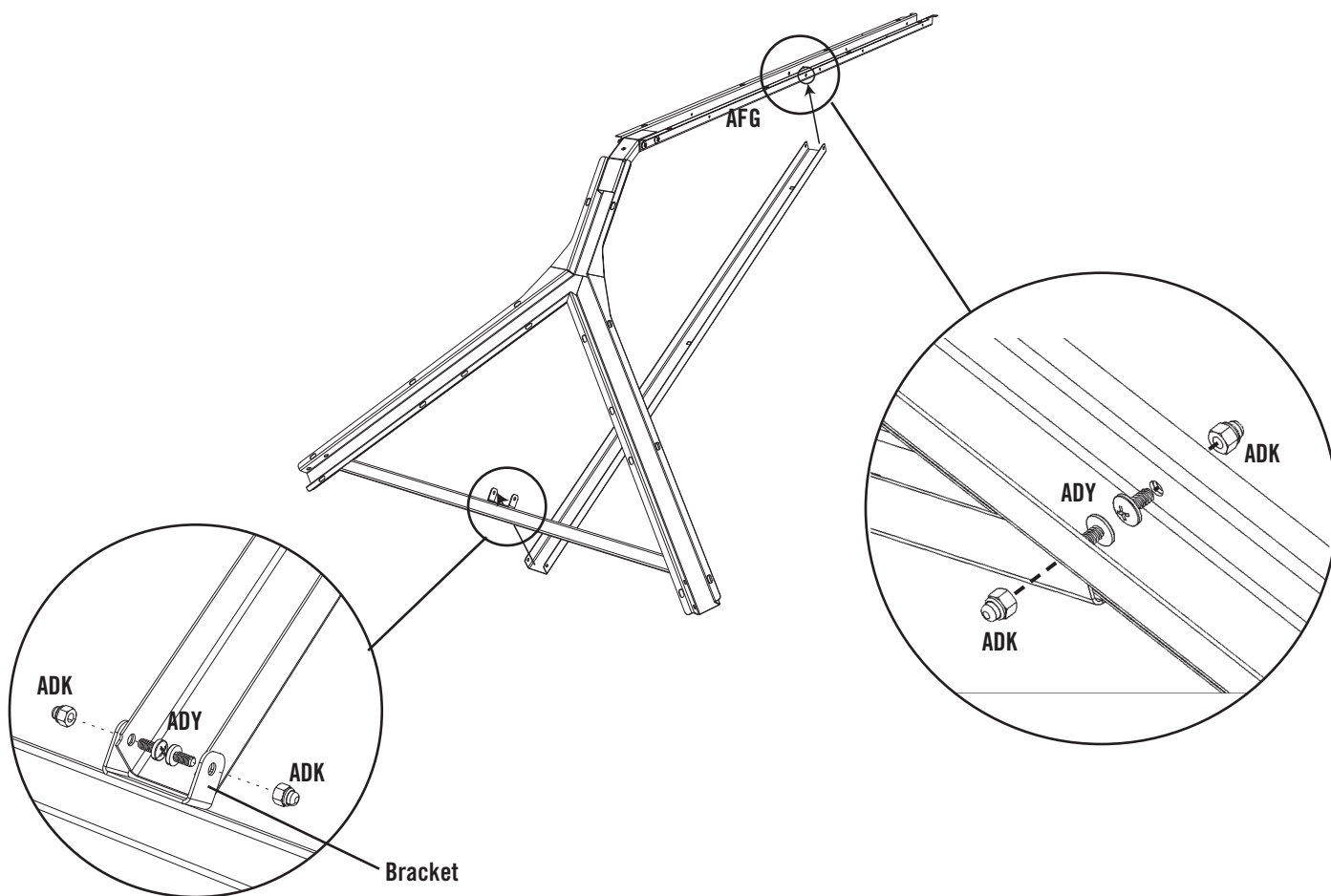

**!** Note: The Roof Truss Brace goes inside the bracket.

**WARNING**  
Do not overtighten the Cap Nut.



## TOOLS AND HARDWARE REQUIRED FOR THIS PAGE



7/16" (x2)



ADJ (x2)

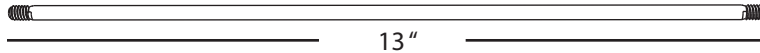

ADH (x1) (Not to scale)

SEC 3

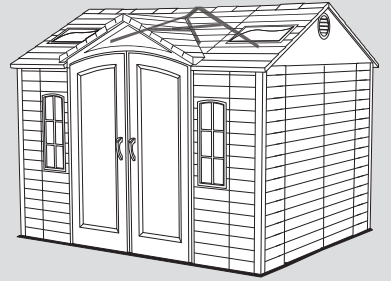

SEC

3.9

Insert a **1/4" Threaded Rod (ADH)** through the Roof Truss Brace and Truss Connector as shown. Ensure channels are parallel, then secure with **1/4" Cap Nuts (ADJ)**. Tighten all hardware. The 1/4" Threaded Rod will still spin freely. Set aside.

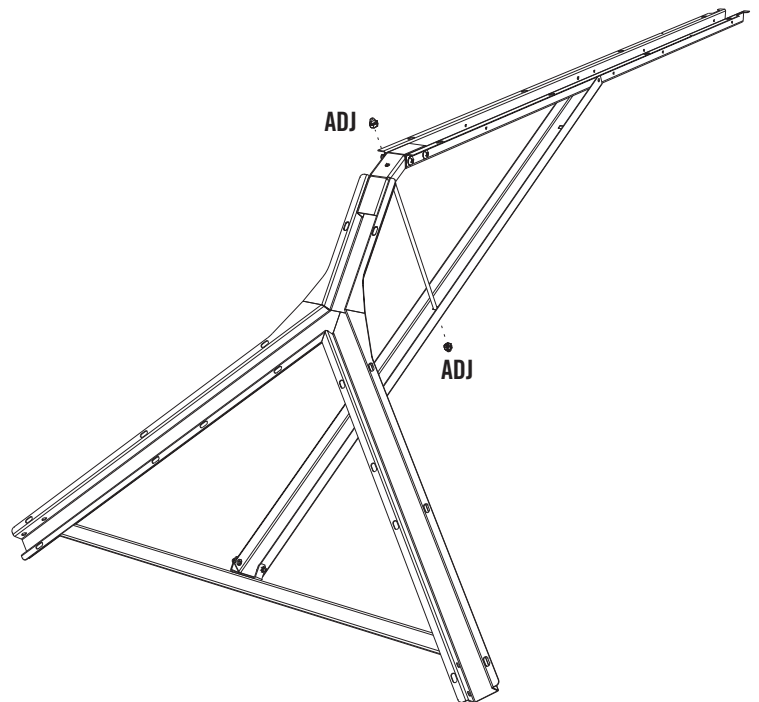
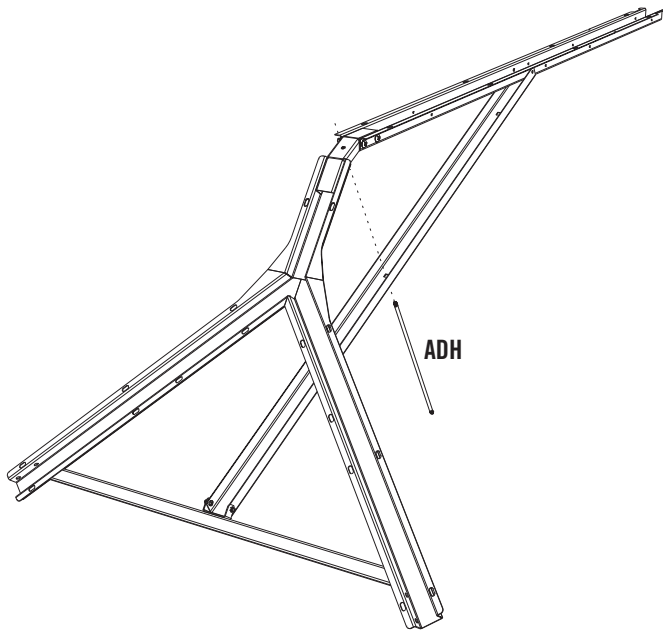

**WARNING**

Do not overtighten the Cap Nut.



## SEC 4 WALL PANEL INSTALLATION

### HARDWARE REQUIRED

**HARDWARE BAG REQUIRED: BEB**

Hardware shown at actual size

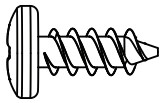

**ADZ** (x85)  
1/4" x 5/8" Pan-Head Screw  
(Not all screws will be used)

### METAL PARTS REQUIRED

**METAL PARTS KIT REQUIRED: CKP**

Part shown at 8% of actual size

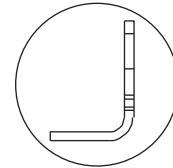
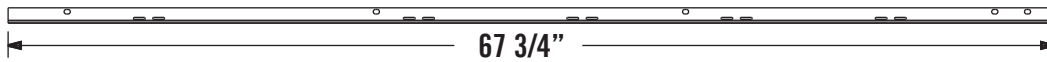

**AFM** (x2)  
Wall Support Channel

### PLASTIC PARTS REQUIRED

Part shown at 4% of actual size

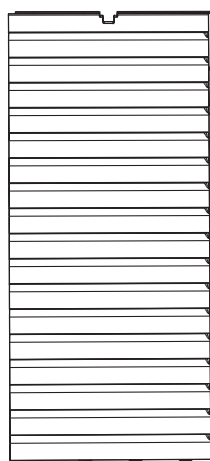
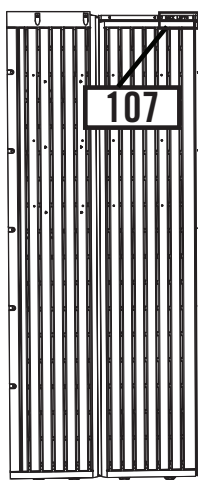
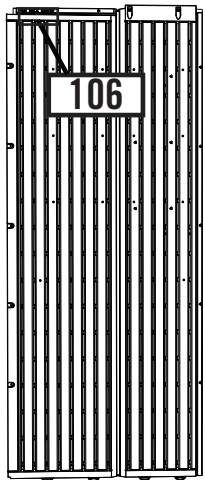

**AGW** (x2)  
Corner Wall Panel 106

**AGL** (x2)  
Corner Wall Panel 107

**AHD** (x6)  
Wall Panel

**AHH** (x1)  
Window Wall Panel



*Note: Pay no attention to the imprinting of "Left" or "Right" on the Corner Wall Panels.*

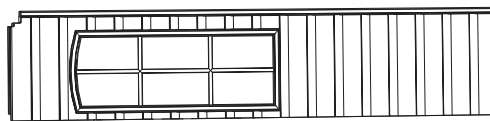
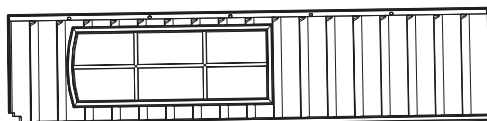

**BDI** (x1)  
Right Half-Window Wall Panel

**BDH** (x1)  
Left Half-Window Wall Panel

### TOOLS REQUIRED

**SMALL PARTS BOX REQUIRED: BUH**

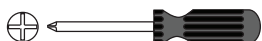

**Phillips Screwdriver**



**Safety Glasses**



**AIW** (x1)  
Wood Block (Included)



## TOOLS AND HARDWARE REQUIRED FOR THIS PAGE

SEC 4



AIW (x1)

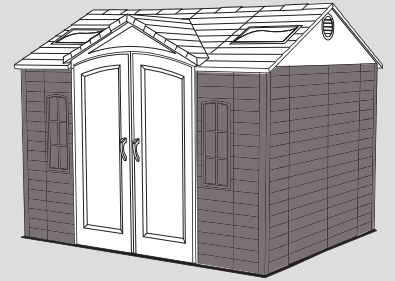

SEC

4.1

### WALL PANEL INSTALLATION

Fold a **Corner Wall Panel 107 (AGL)**. Fit tabs of Panel into the front, left corner of your Floor (while facing shed). Place a **Wood Block (AIW)** under floor panel, directly under the first tab, then pull down on the Corner Panel until the tab snaps into place. Move the Wood Block under the next tab and repeat.

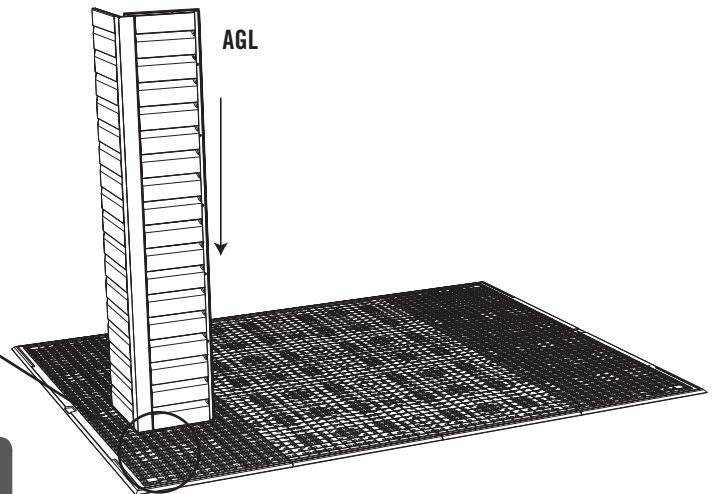
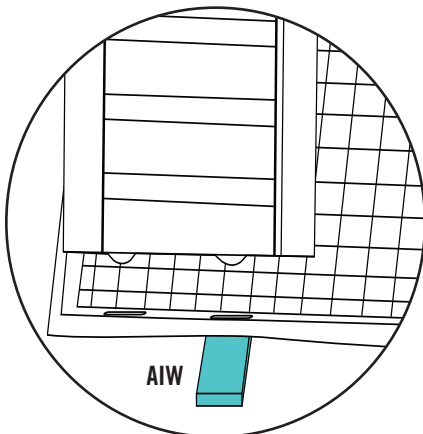

*Note: Place the Wood Block (AIW) directly under the tabs as you insert them throughout the assembly. Snap tabs into place one at a time.*

SEC

4.2

Snap **Wall Panels (AHD)** into place along the side of the shed. Ensure the tops of the Wall Panels are even and the holes align. Use one (1) **1/4" x 5/8" Pan-Head Screw (ADZ)** to fasten the top of the Panels together as shown. You'll finish fastening the panels together towards the end of this section.

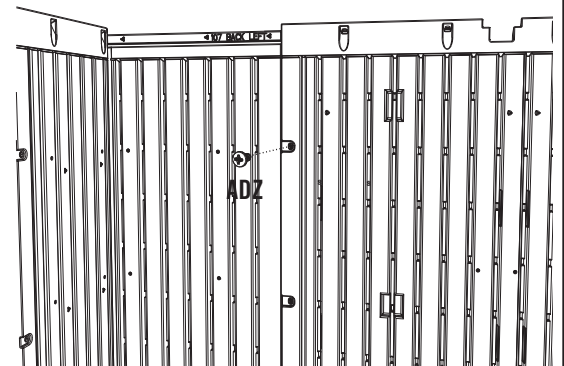
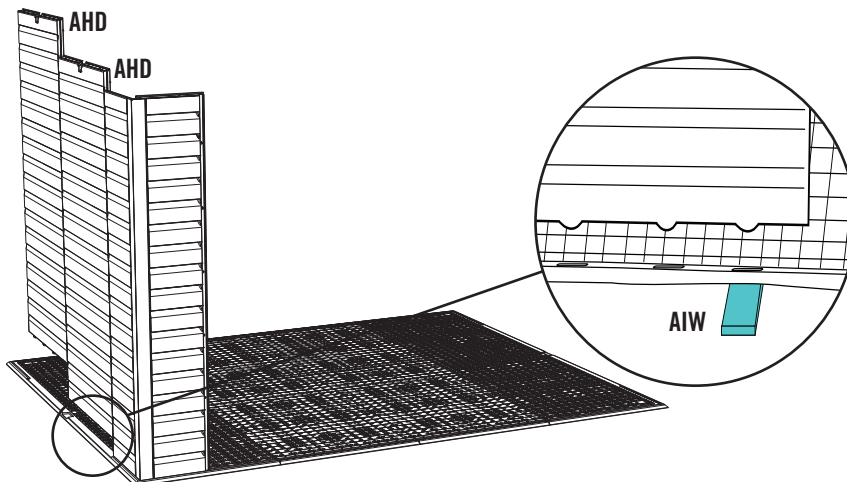

*Note: A second person should apply pressure on opposite side of the Wall Panels for easier insertion of the Screw. Do not overtighten Screw.*



## TOOLS AND HARDWARE REQUIRED FOR THIS PAGE

SEC. 4



AIW (x1)

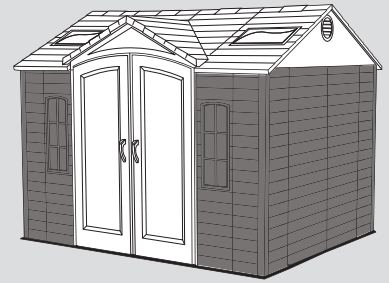

SEC

4.3

Fold a **Corner Wall Panel 106 (AGW)**. Snap into place and fasten at the top hole with the required hardware.

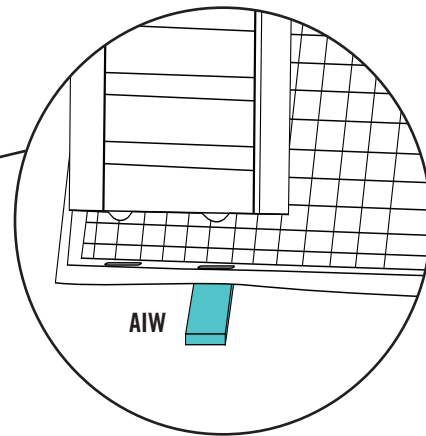
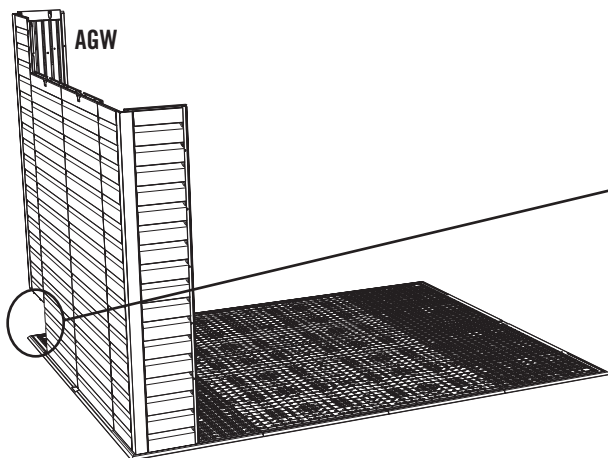

SEC

4.4

Insert two **Wall Panels (AHD)** and a **Window Wall Panel (AHH)** along back side of shed. The Window Wall Panel may be placed in any rear Wall Panel position. Ensure holes line up and fasten Panels at the top hole with the required hardware.

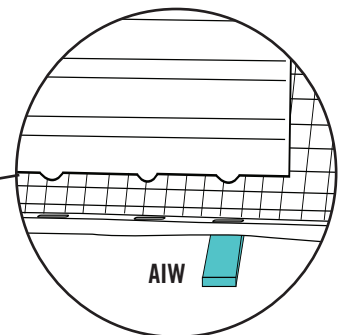
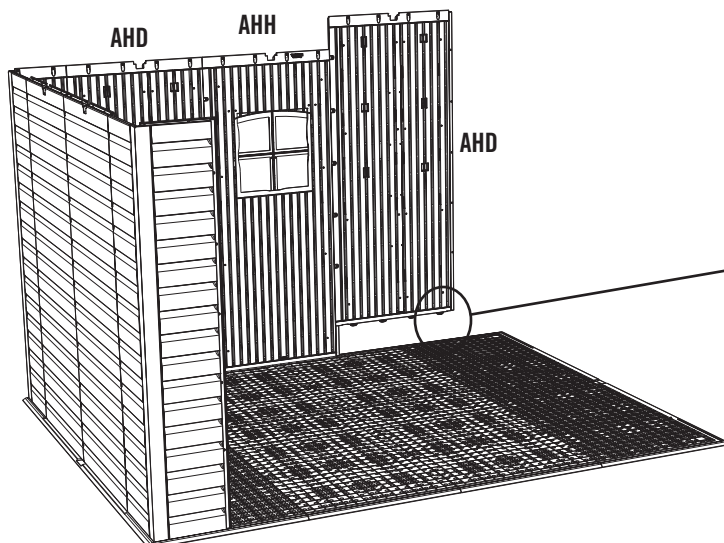



## TOOLS AND HARDWARE REQUIRED FOR THIS PAGE

SEC 4



AIW (x1)

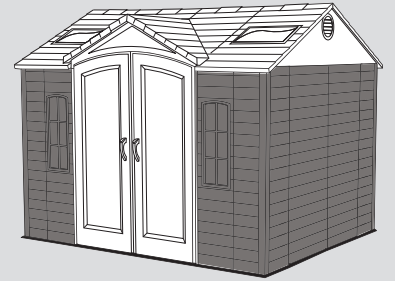

SEC

4.5

Fold a **Corner Wall Panel 107 (AGL)** and fasten to the rear Wall Panel in the top hole using the required hardware.

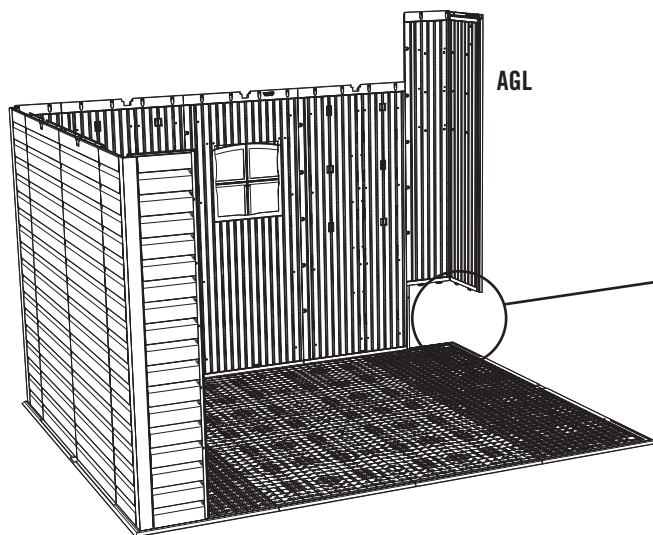

AIW

SEC

4.6

Snap **Wall Panels (AHD)** into place along the side of the shed. Ensure the tops of the Wall Panels are even and the holes align. Use one (1) **1/4" x 5/8" Pan-Head Screw (ADZ)** to fasten the top of the Panels together as shown. You'll finish fastening the panels together towards the end of this section.

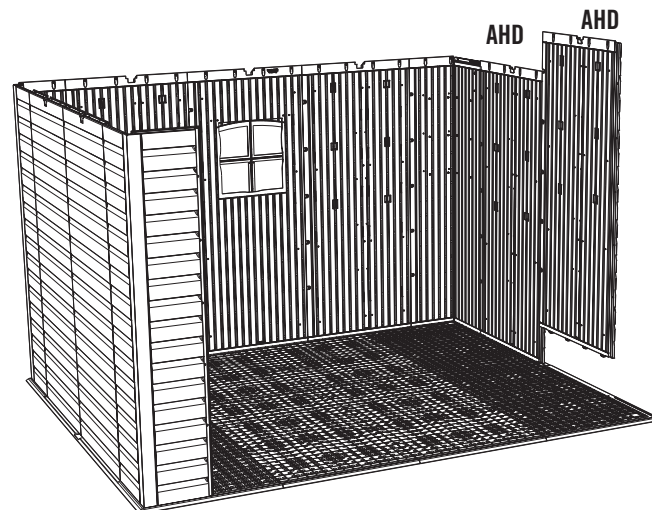



## TOOLS AND HARDWARE REQUIRED FOR THIS PAGE

SEC. 4



AIW (x1)

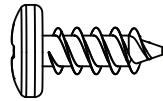

ADZ (x51)

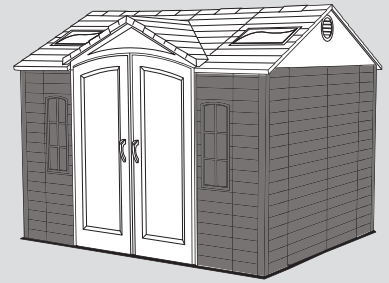

SEC

4.7

Fold the second **Corner Wall Panel 106 (AGW)** and snap it into place at the right, front corner of the Floor as shown. Fasten it to the Wall Panel in the top hole using the required hardware.

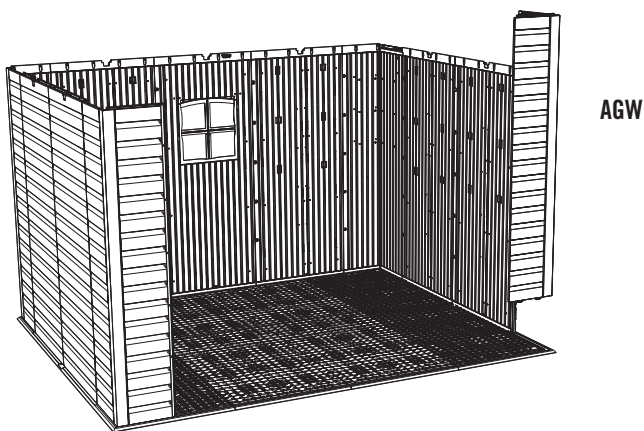

SEC

4.8

Snap the **Left and Right Half-Window Wall Panels (BDI & BDH)** into place along the front of the Shed. After ensuring holes line up, fasten Panels together with the required hardware. Finish fastening all Panels together with rest of the **1/4" x 5/8" Pan-Head Screws (ADZ)** for all holes.

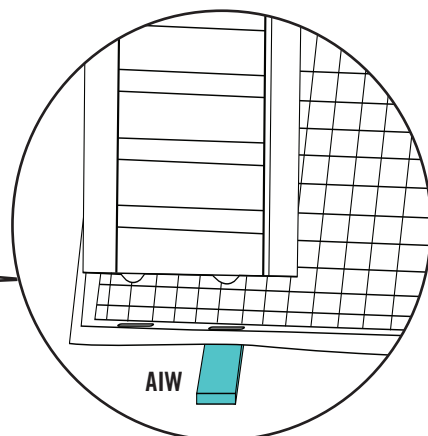
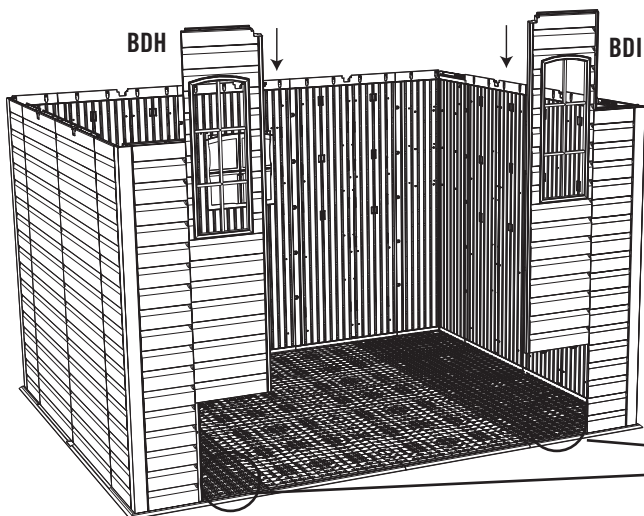

AIW





# TOOLS AND HARDWARE REQUIRED FOR THIS PAGE



# SEC 4

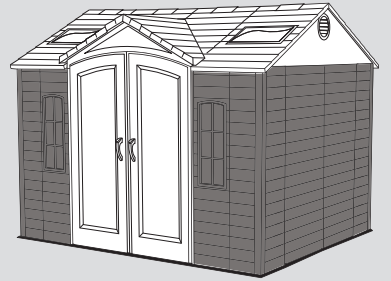

## SEC

### 4.9

Attach a **Wall Support Channel (AFM)** to the Right Half-Window Wall Panel, and secure with four (4) **1/4" x 5/8" Pan-Head Screws (ADZ)**.

Use 2nd groove from the right

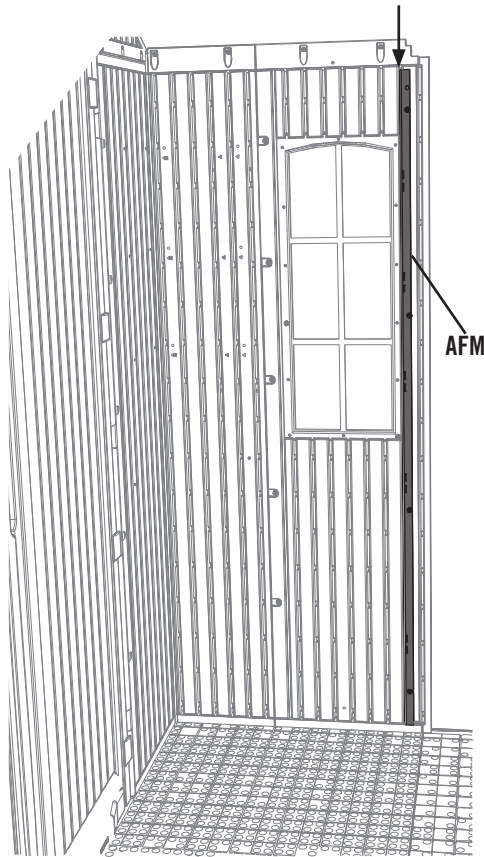

Use 2nd groove from the right

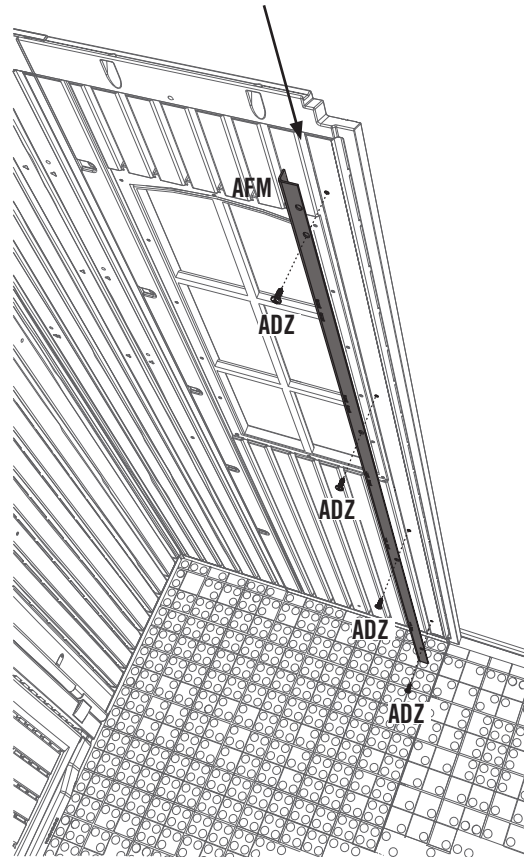

*Note: Use second groove in from edge for Right Half-Window Wall Panel (BDH).*





## TOOLS AND HARDWARE REQUIRED FOR THIS PAGE



SEC. 4

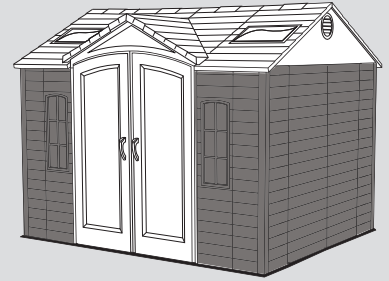

SEC

4.10

Attach a **Wall Support Channel (AFM)** to the Left Half-Window Wall Panel (use the first groove in from the edge, and secure with four (4) **1/4" x 5/8" Pan-Head Screws (ADZ)**).

Use 1st groove from the left

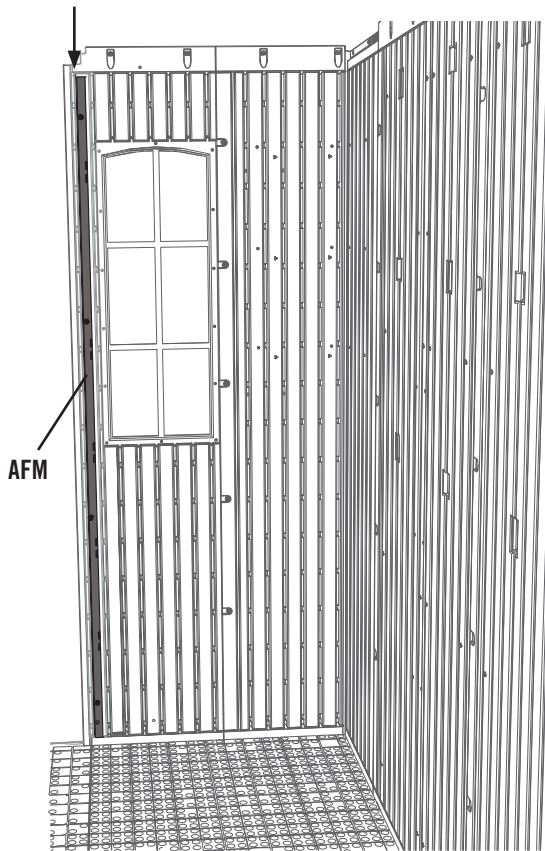

Use 1st groove from the left

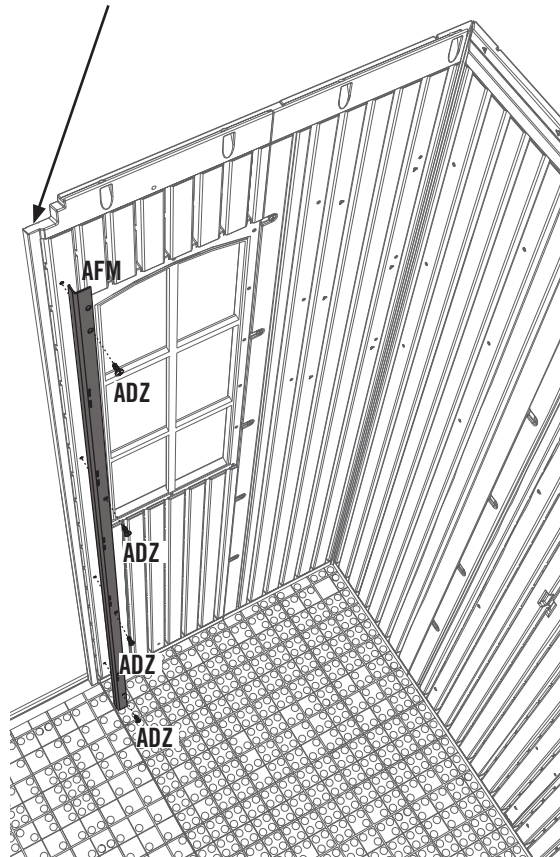

*Note: Use first groove in from edge for Left Half-Window Wall Panel (BDI).*

**SEC 5 DOMED SKYLIGHT ASSEMBLY**

**HARDWARE REQUIRED**

**HARDWARE BAG REQUIRED: BEC (x2)**

Hardware is actual size (\*Unless indicated otherwise)

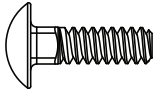

**ACR (x24)**  
#10 x 5/8" Carriage Bolt



**ADK (x24)**  
#10 Cap Nut

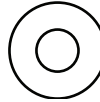

**AEE (x24)**  
#10 x 1/2" Flat Washer



**\*AHI (x2) Butyl Tape**

**PLASTIC PARTS REQUIRED**

**SMALL PARTS KIT REQUIRED: CQM**

Part shown at 4% actual size

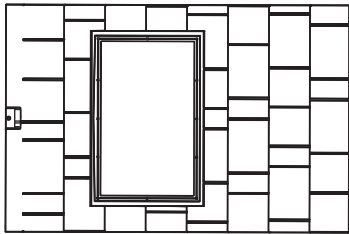

**AHB (x2)**  
Roof Panel for Domed Skylight

Part shown at 8% actual size

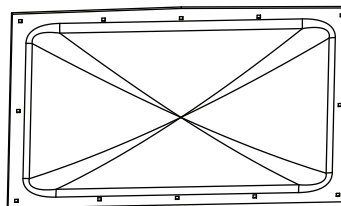

**AGB (x2)**  
Domed Skylight

**TOOLS REQUIRED**

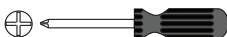

**Plain Screwdriver**



**3/8" Wrench**



**Safety Glasses**



## TOOLS AND HARDWARE REQUIRED FOR THIS PAGE

SEC 5



AHI (x2)  
(Not to scale)

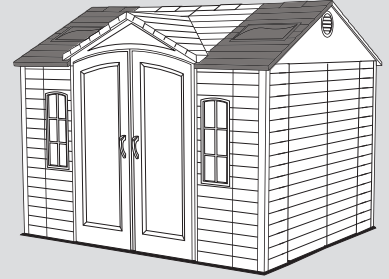

SEC

### DOMED SKYLIGHT ASSEMBLY

5.1

Use a plain screwdriver to gently remove any excess plastic from the twelve holes in the **Roof Panel for Domed Skylight (AHB)**. It's important that the hole stay square; try not to round the corners of the edges of the holes.

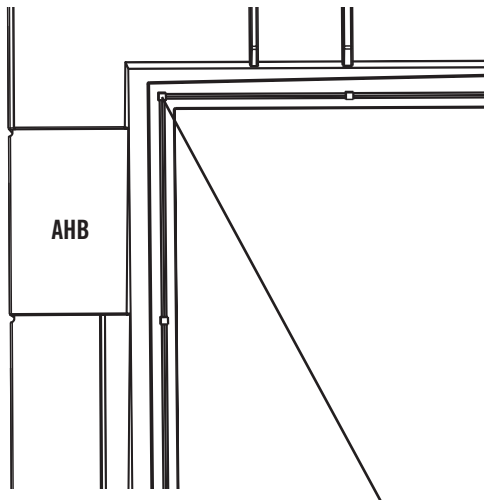

**!** Note: Use a plain screwdriver to remove any excess plastic from all holes in Panel. Ensure the holes remain square.

SEC

5.2

Stick the end of the **Butyl Tape (AHI)** over the groove and top, left hole of the Roof Panel for Domed Skylight as indicated below. Move to the right and over the groove covering all the holes along the top of the opening. Once the top, right corner and hole are covered, cut the Butyl Tape. Run your finger along the paper backing pressing down slightly to remove any gaps or bubbles between the Butyl Tape and the groove. Remove the paper backing from the piece you just applied. Overlap the end of the roll of Butyl Tape with the end you just cut and apply the Butyl Tape over the holes along the groove on the right of the opening. Continue applying the Butyl Tape in this fashion until all holes have been covered and the ends overlap.

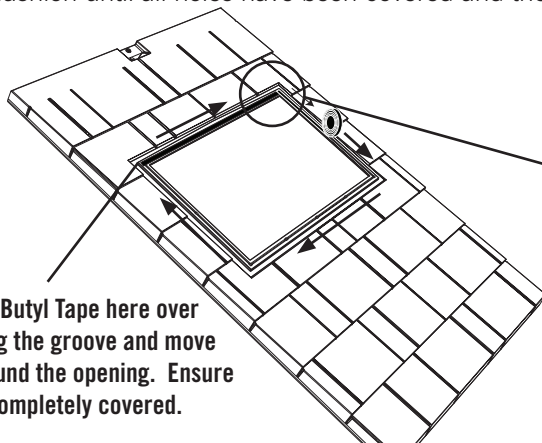

Start applying Butyl Tape here over the holes along the groove and move clockwise around the opening. Ensure all holes are completely covered.

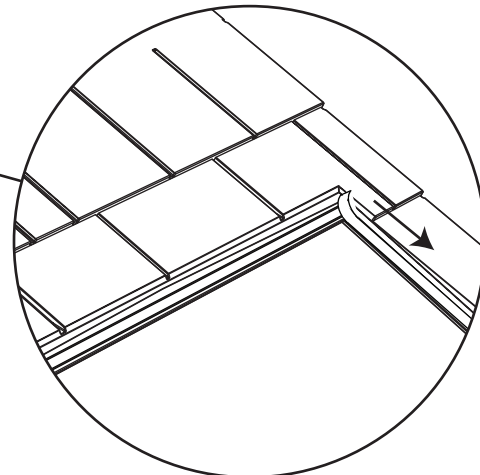

**!** Note: Butyl Tape must overlap at ends and cover all twelve holes.



## TOOLS AND HARDWARE REQUIRED FOR THIS PAGE

SEC. 5



NO HARDWARE REQUIRED FOR THIS PAGE

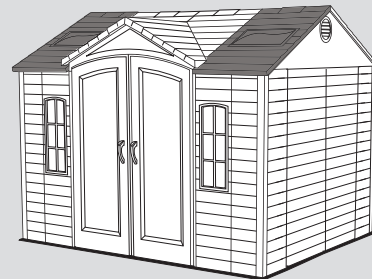

SEC

5.3

Insert a screwdriver through the Butyl Tape and into the twelve holes. This will help you align the holes in the Domed Skylight with those in the Roof Panel for Domed Skylight in the next step.

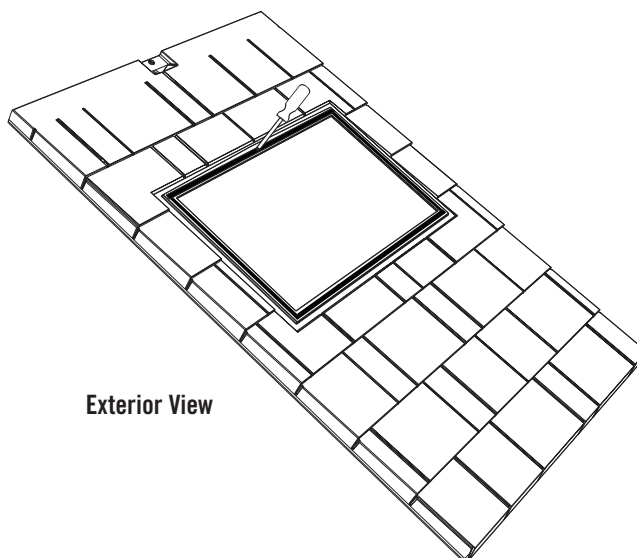

Exterior View

SEC

5.4

Remove the protective plastic film from **both** sides of the **Domed Skylight (AGB)**. Carefully align the holes in the Domed Skylight with those in the Butyl Tape. Set the Domed Skylight over the opening in the Roof Panel for Domed Skylight. Press down and verify there are no gaps or bubbles between the Butyl Tape and the Domed Skylight.

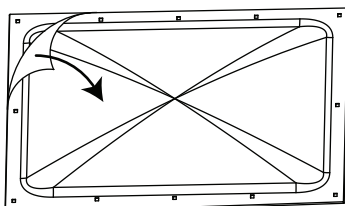

AGB

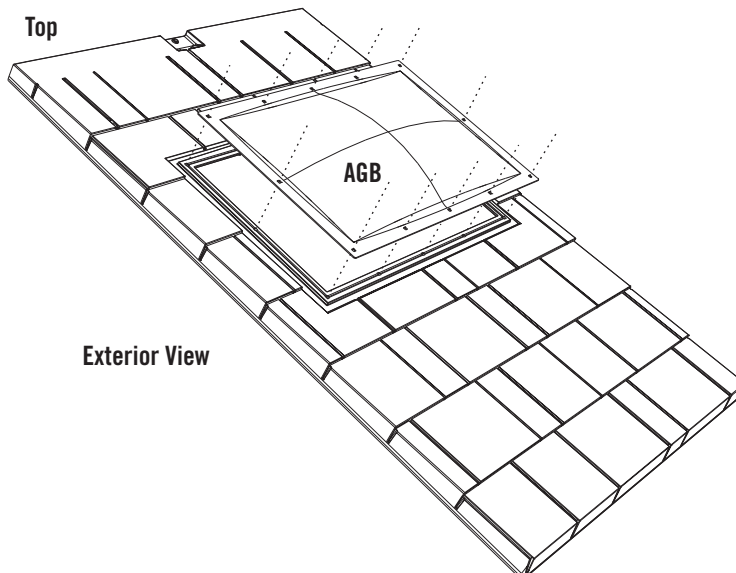

Exterior View



## TOOLS AND HARDWARE REQUIRED FOR THIS PAGE

SEC 5



3/8"

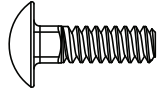

ACR (x24)



ADK (x24)

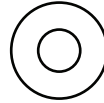

AEE (x24)

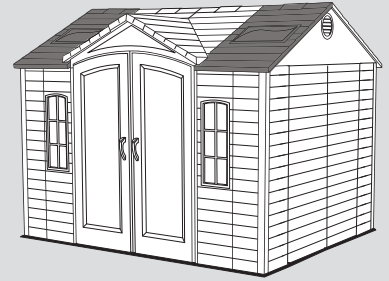

SEC

5.5

Insert one **#10 x 5/8" Carriage Bolt (ACR)** through each hole in the Domed Skylight. Press the Bolt through the Butyl Tape and through the Roof Panel for Domed Skylight. The necks of the Carriage Bolts fit into the square holes in the Domed Skylight.

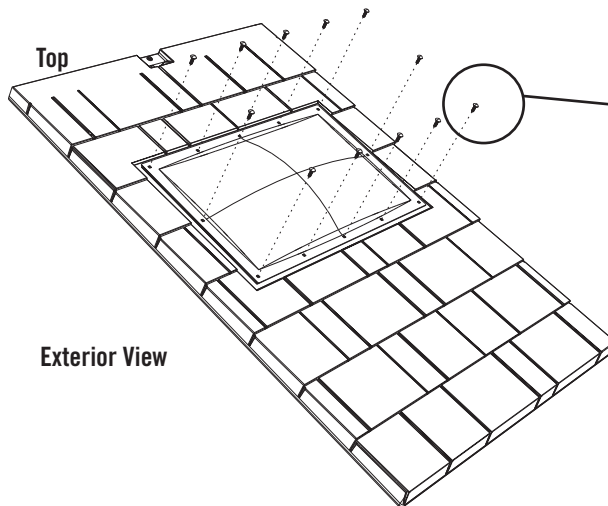

Exterior View

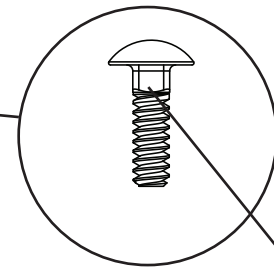

Neck of Carriage Bolt

SEC

5.6

Secure the Domed Skylight to the Roof Panel for Domed Skylight with one (1) **#10 x 1/2" Flat Washer (AEE)** and one (1) **#10 Cap Nut (ADK)** for each Carriage Bolt. Set Skylight/Panel Assembly aside. Repeat this section for the second Roof Panel for Domed Skylight.

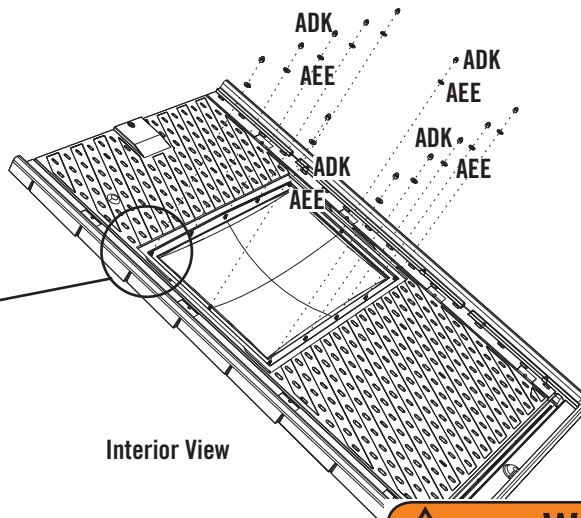
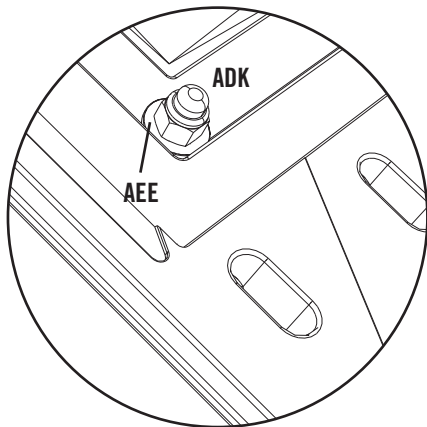

Interior View



### WARNING

Do not overtighten the Cap Nut. If the end of the Bolt breaks through the plastic cap, call our Customer Service Department. Exposed threads on the end of the Bolt may cause serious injuries.

## SEC 6 GABLE ASSEMBLY

### HARDWARE REQUIRED

Hardware shown at actual size

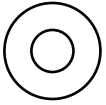

**AEE** (x10)  
#10 x 1/2" Flat Washer

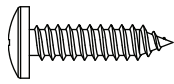

**ADW** (x10)  
#10 x 3/4" Pan-Head Screw

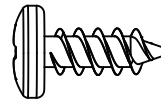

**ADZ** (x8)  
1/4" x 5/8" Pan-Head Screw

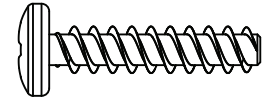

**ADV** (x12)  
1/4" x 1 1/8" Pan-Head Screw  
(Not used)

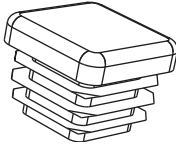

**AHS** (x4)  
End Plug  
(Not used)

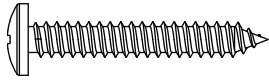

**ACB** (x2)  
#10 x 1 1/4" Pan-Head Screw  
(Not used in this model)

Parts shown at 8% of actual size



**AGP** (x2)  
Louvered Vent

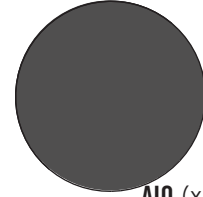

**AIQ** (x2)  
Vent Screen

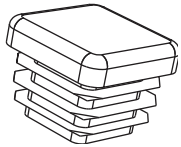

**AHS** (x2)  
End Plug

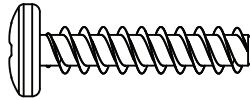

**ADV** (x4)  
1/4" x 1 1/8" Pan-Head Screw

### METAL PARTS REQUIRED

Parts shown at 8% of actual size



**BDD** (x1) Entry Gable Header Bar

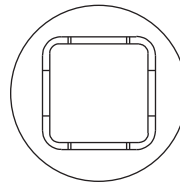

### METAL PARTS KIT REQUIRED: CKP

### PLASTIC PARTS REQUIRED

Parts shown at 4% of actual size

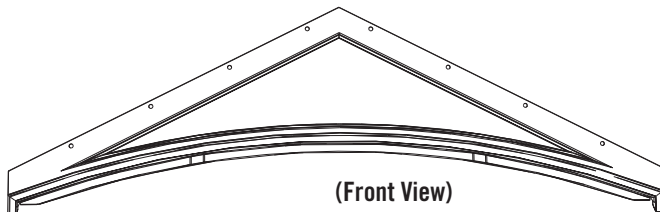

**BDC** (x1)  
Front Entry Gable

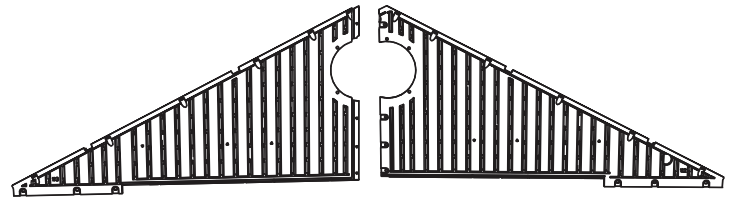

**AGH** (x2)  
Side Gable 1

(Rear View)

**AGI** (x2)  
Side Gable 2

(Rear View)

### TOOLS REQUIRED



Phillips Screwdriver



Safety Glasses





## TOOLS AND HARDWARE REQUIRED FOR THIS PAGE

SEC 6

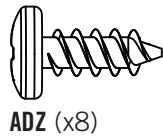

ADZ (x8)

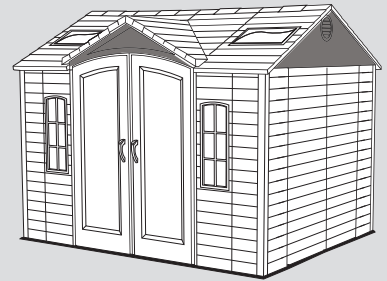

SEC

### SIDE GABLE ASSEMBLY

6.1

Lay the edge of **Side Gable 2 (AGI)** over **Side Gable 1 (AGH)** as shown, and align the four holes.

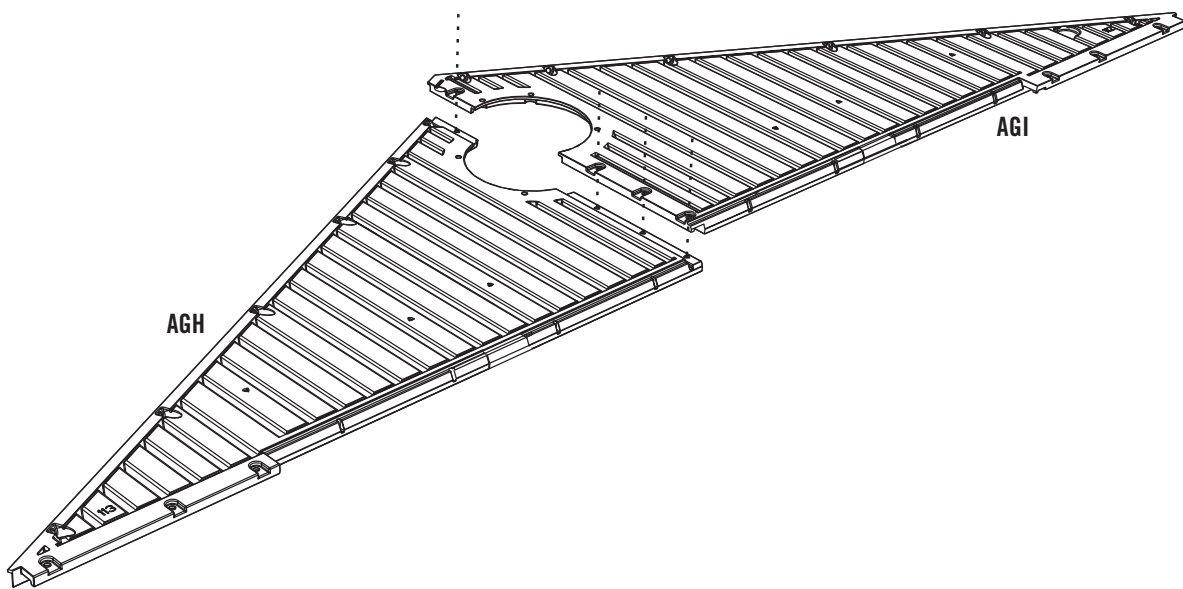

SEC

6.2

Connect Side Gables 1 & 2 together using four (4) 1/4" x 5/8" Pan-Head Screws (ADZ) as shown.

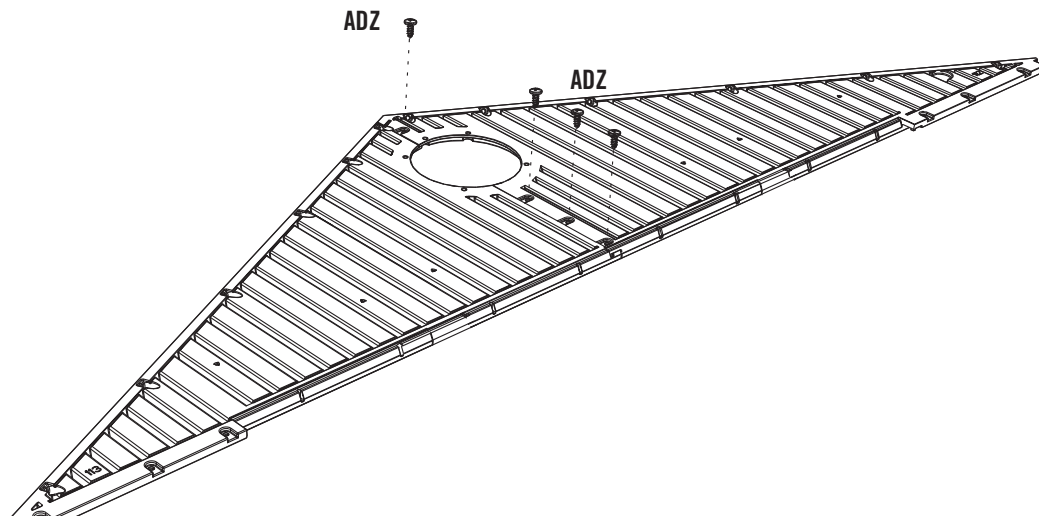

*Note: Only use a hand screwdriver in this step.*



## TOOLS AND HARDWARE REQUIRED FOR THIS PAGE

SEC. 6

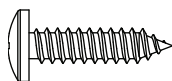

ADW (x10)

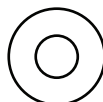

AEE (x10)

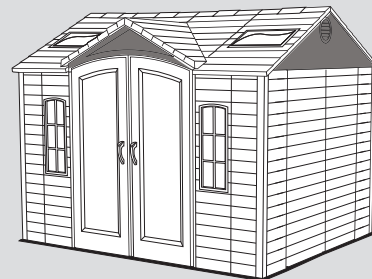

SEC

6.3

Lay Side Gable Assembly flat on the ground over the **Vent Screen (AIQ)** and **Louvered Vent (AGP)**. Align the holes in the Louvered Vent with those in the Side Gable Assembly.

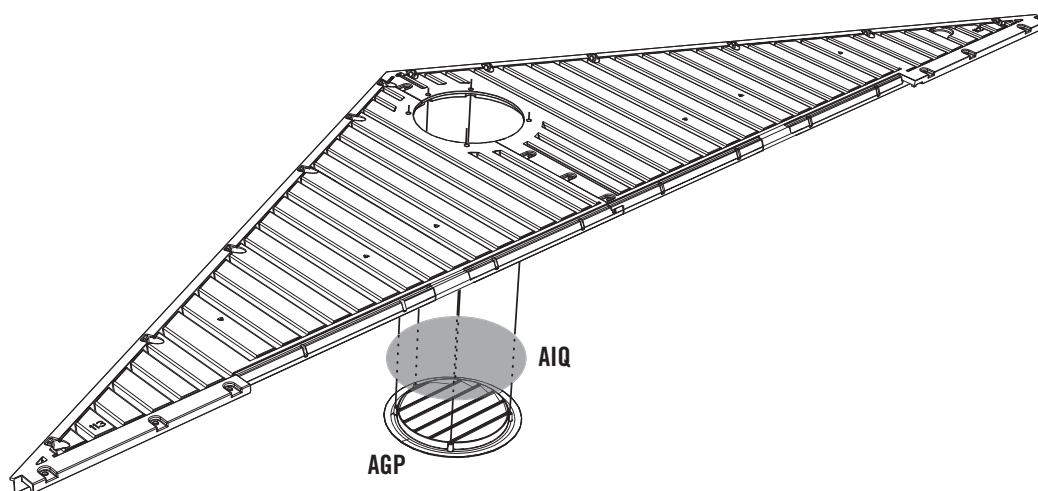

SEC

6.4

After aligning the holes, press down firmly on the Side Gable Assembly when inserting the five (5) **#10 x 3/4" Pan-Head Screws (ADW)** and the five (5) **#10 x 1/2" Flat Washers (AEE)**. Pressing down firmly while inserting the Screws will help prevent the Vent Screen from twisting while inserting the Screws. **Repeat the previous steps for the second Side Gable.**

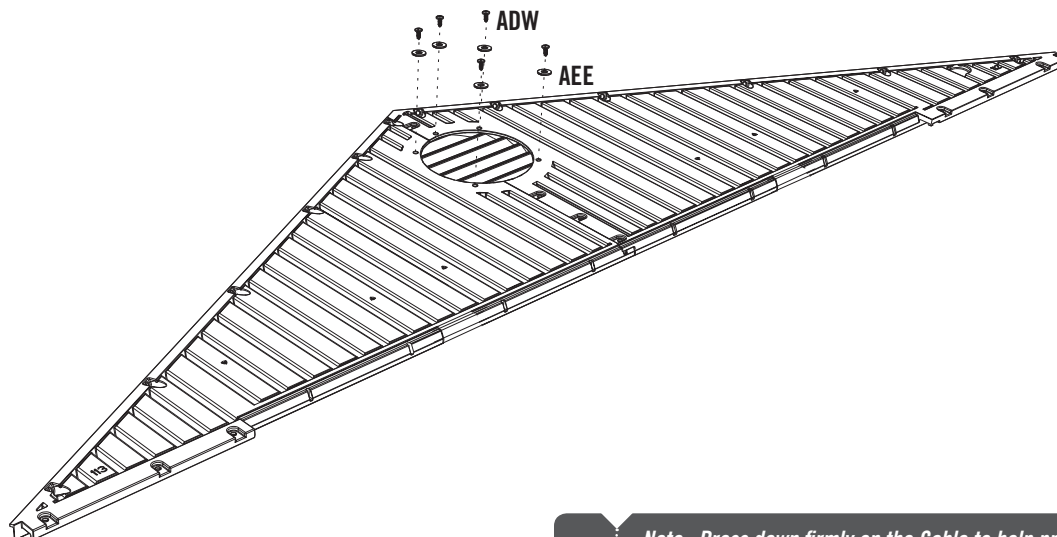

*Note: Only use a hand screwdriver in this step.*



*Note: Press down firmly on the Gable to help prevent the Screen from twisting while inserting the Screws.*



## TOOLS AND HARDWARE REQUIRED FOR THIS PAGE

SEC. 6

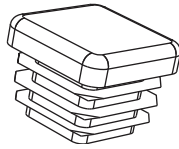

AHS (x2)

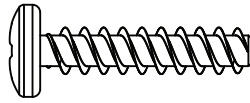

ADV (x4)

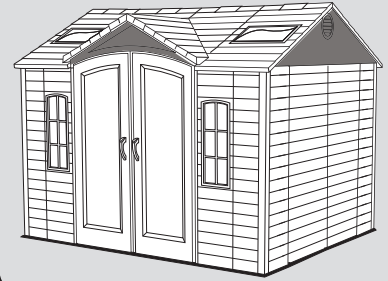

SEC

### FRONT ENTRY GABLE ASSEMBLY

6.5

Insert one **End Plug (AHS)** into each end of the **Entry Gable Header Bar (BDD)** as shown, and align the four holes in the Entry Gable Header Bar with those in the **Front Entry Gable (BDC)**.

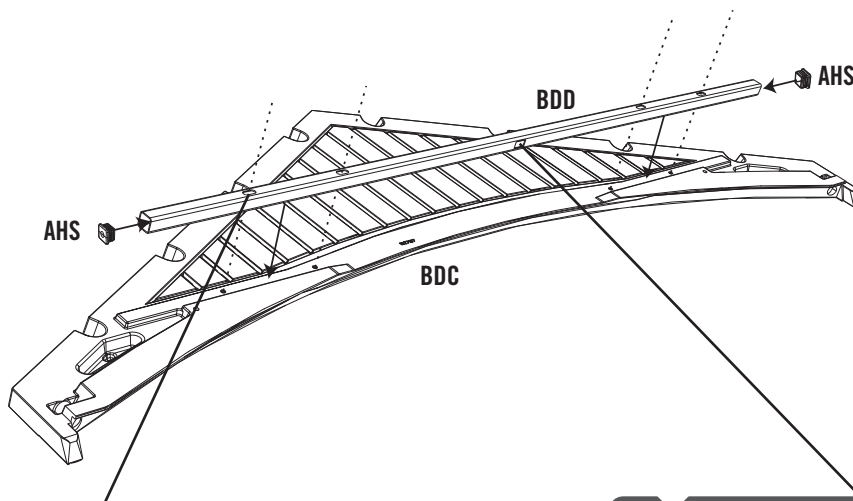

*Note: The indented, oval holes face toward the Gable.*



*Note: The indented, square hole faces downward and to the right of center.*

SEC

6.6

Attach the Entry Gable Header Bar to the Front Entry Gable using four (4) **1/4" x 1 1/8" Pan-Head Screws (ADV)**. Set aside.

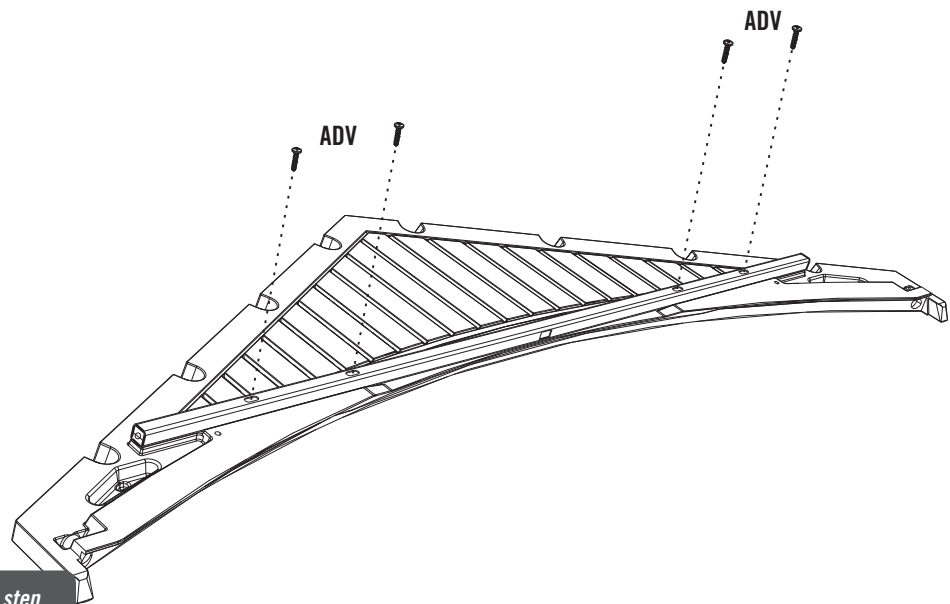

*Note: Only use a hand screwdriver in this step.*

## SEC 7 LEFT DOOR ASSEMBLY

### HARDWARE REQUIRED

### HARDWARE BAG REQUIRED: BEF

Hardware shown at actual size

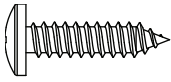

**ADW** (x3)  
#10 x 3/4" Pan-Head Screw

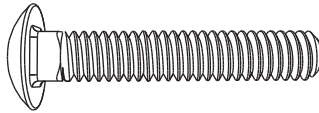

**ABU** (x2)  
1/4" x 1 1/2" Carriage Bolt



**ADJ** (x2)  
1/4" Cap Nut

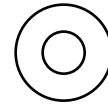

**AEE** (x3)  
#10 x 1/2 Flat Washer

Part shown at 25% of actual size

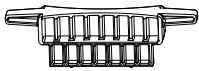

**AHM** (x2)  
Deadbolt Latch

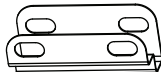

**AIB** (x1)  
Left Door Strike Plate



**AIA** (x1)  
Left Door Lock Bracket

Part shown at 15% of actual size



**AHZ** (x1)  
Left Door Handle

### METAL PARTS REQUIRED

### METAL PARTS KIT REQUIRED: CKP

Part shown at 8% of actual size



**AFC** (x1)  
Door End Channel

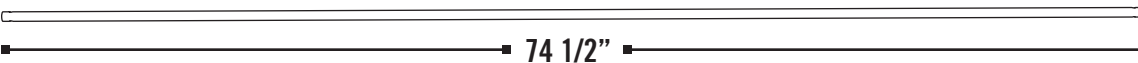
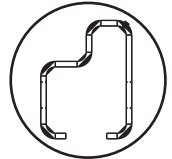

**CRE** (x2)  
Door Hinge Tube

### PLASTIC PARTS REQUIRED

Part shown at 4% of actual size

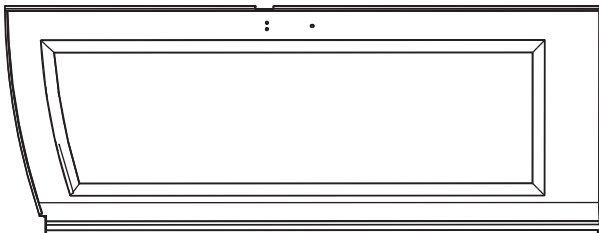

**BDJ** (x1)  
Left Front Door

### TOOLS REQUIRED



Phillips Screwdriver



7/16" Wrench



Safety Glasses



## TOOLS AND HARDWARE REQUIRED FOR THIS PAGE

SEC 7

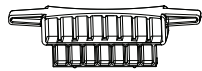

AHM (x2)

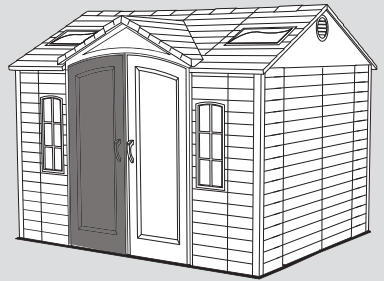

SEC

### LEFT DOOR ASSEMBLY

7.1

Rest the **Left Shed Door (BDJ)** with front side down. Slide a **Door Hinge Tube (CRE)** through the hole in the Door as shown.

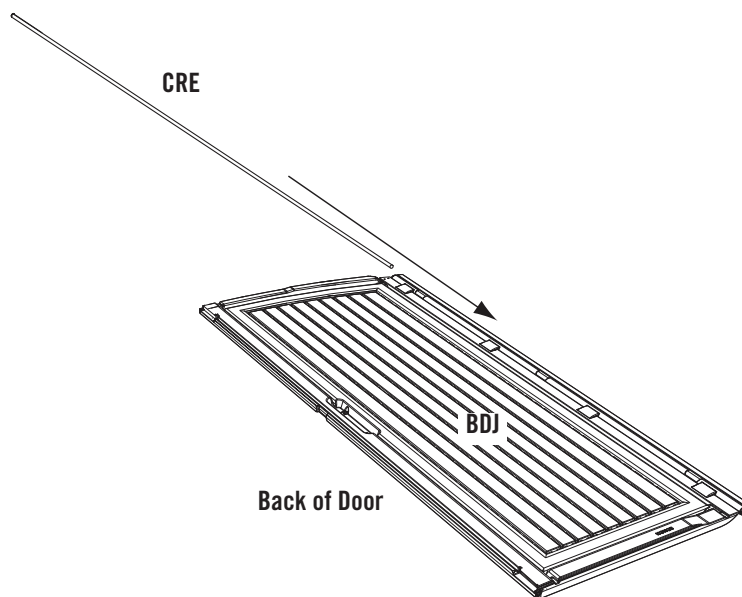

SEC

7.2

Position the **Deadbolt Latches (AHM)** in slots at the top and bottom of the Door, then slide the **Door End Channel (AFC)** onto the Door as shown.

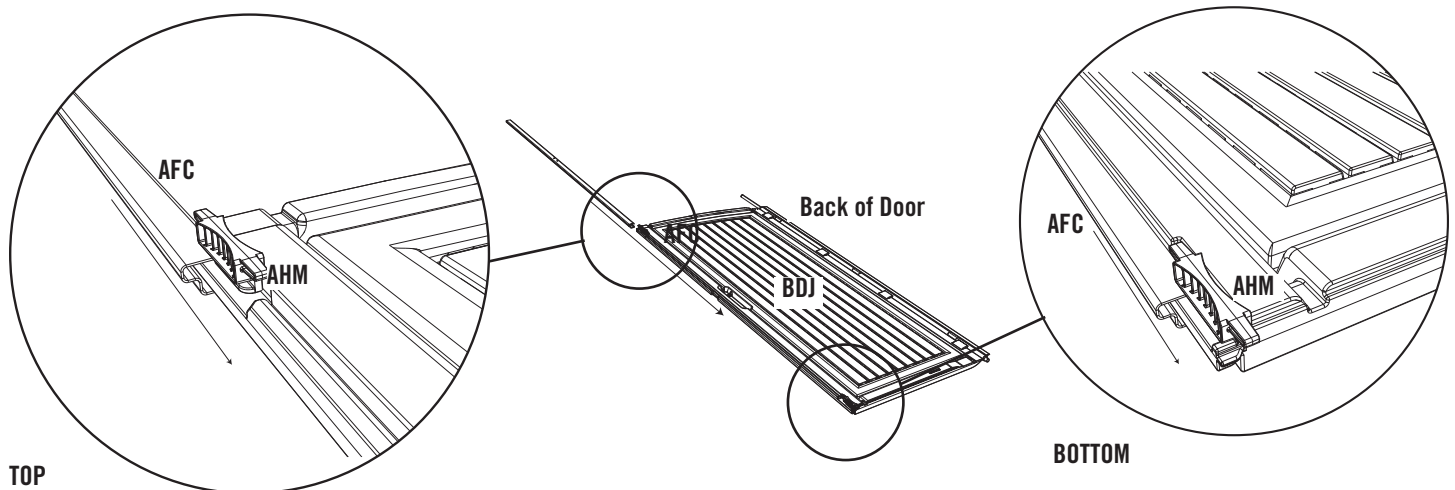

TOP

BOTTOM



*Note: The Door End Channel fits onto Door with the flat side up (facing the Deadbolt Latches).*



## TOOLS AND HARDWARE REQUIRED FOR THIS PAGE

SEC 7

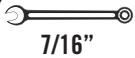

7/16"

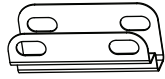

AIB (x1)

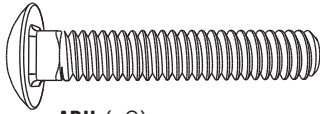

ABU (x2)



ADJ (x2)



AIA (x1)

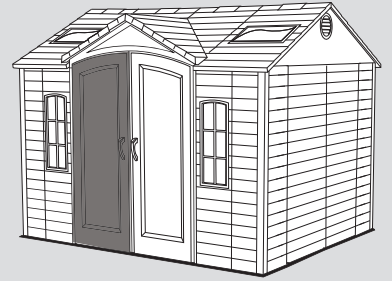

SEC

7.3

Slip the **Left Door Strike Plate (AIB)** over the Left Shed Door and align the holes.

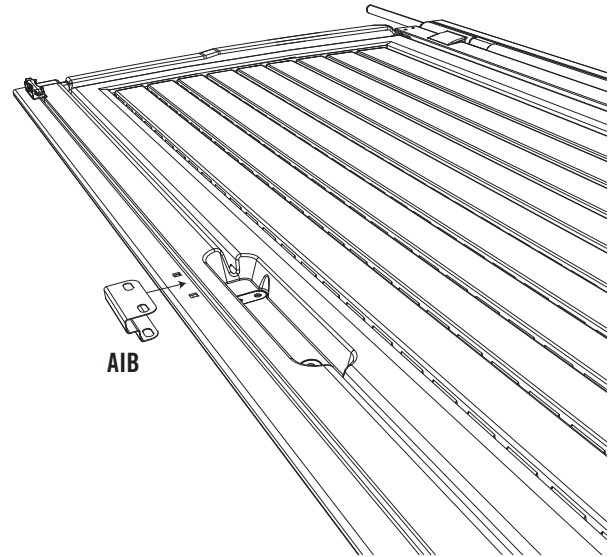

*Note: You may need to nudge the Door End Channel to make these holes line up with the gap in the Door.*

SEC

7.4

Attach the **Left Door Lock Bracket (AIA)** to the Left Door Strike Plate with two (2) **1/4" x 1 1/2" Carriage Bolts (ABU)** and two (2) **1/4" Cap Nuts (ADJ)**.

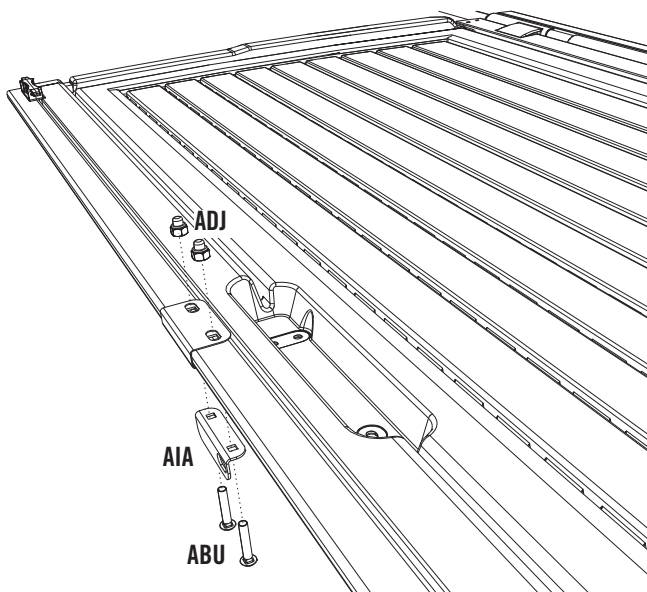

### WARNING

Do not overtighten the Cap Nut. If the end of the Bolt breaks through the plastic cap, call our Customer Service Department. Exposed threads on the end of the Bolt may cause serious injuries.





## TOOLS AND HARDWARE REQUIRED FOR THIS PAGE

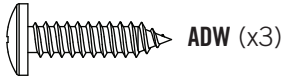
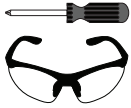

SEC 7

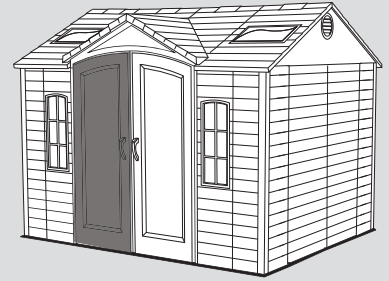

SEC

7.5

Attach the **Left Door Handle (AHZ)** to the Door using three **#10 x 1/2" Flat Washers (AEE)** and three **#10 x 3/4" Pan-Head Screws (ADW)**.

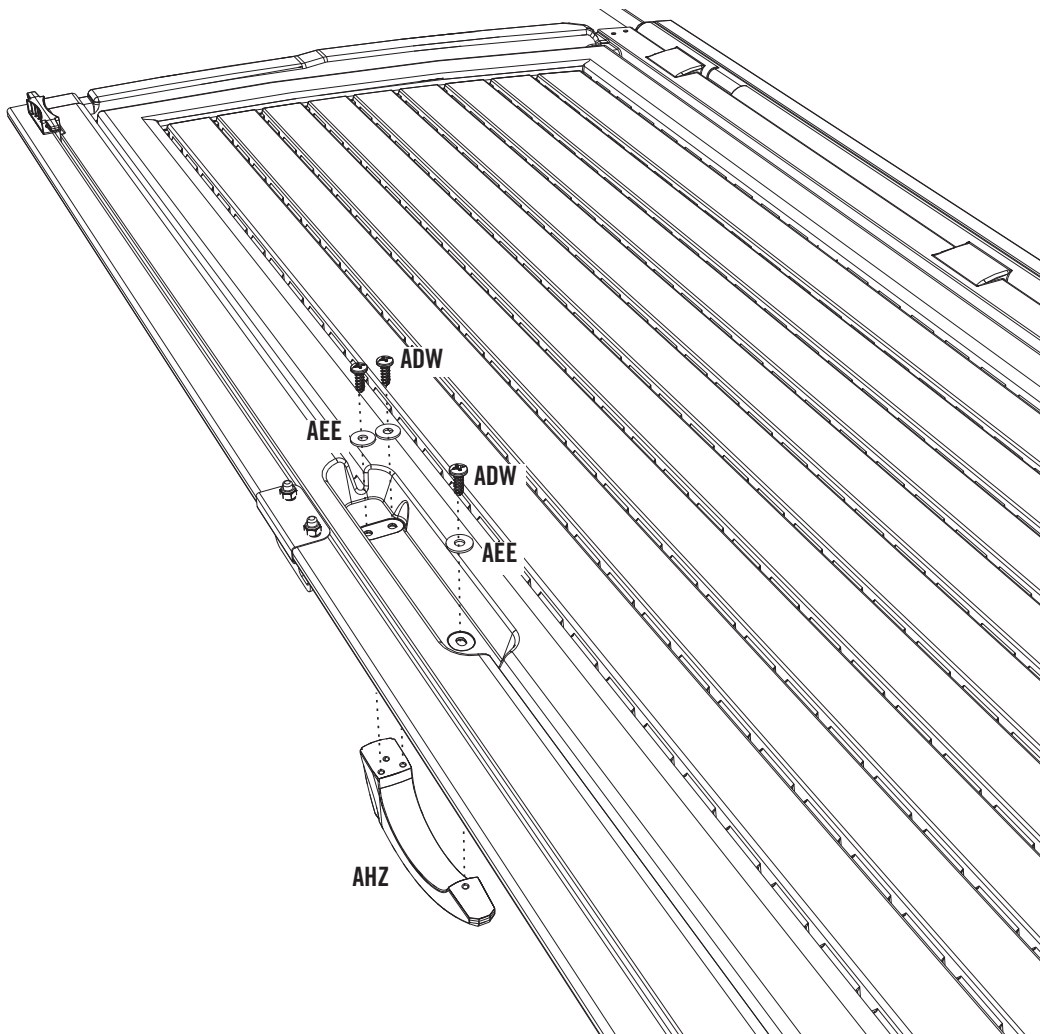

**SEC 8 RIGHT DOOR ASSEMBLY**

**HARDWARE REQUIRED**

**HARDWARE BAG REQUIRED: BEG**

Hardware shown at actual size

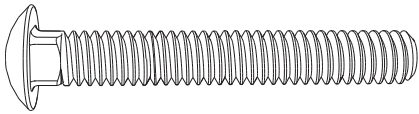

**ABV (x2)**  
1/4" x 2" Carriage Bolt

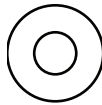

**AEE (x3)**  
#10 x 1/2" Flat Washer

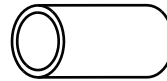

**ADB (x2)**  
3/8" x 1/2" Steel Spacer

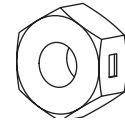

**AAB (x2)**  
1/4" Centerlock Nut

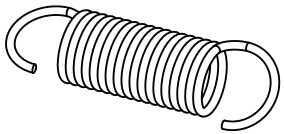

**AHY (x1)**  
Latch Spring

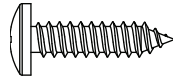

**ADW (x4)**  
#10 x 3/4" Pan-Head Screw

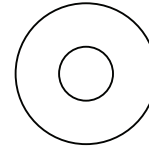

**AEB (x2)**  
1/4" Flat Washer

Part shown at 25% of actual size

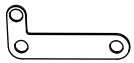

**AHX (x1)**  
Latch Cover Plate

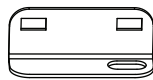

**AIL (x1)**  
Right Door Lock Bracket

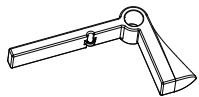

**AHV (x1)**  
Door Latch

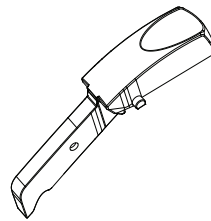

**AIO (x1)**  
Thumb Lever

Part shown at 15% of actual size



**AIK (x1)**  
Right Door Handle

Part shown at 50% of actual size

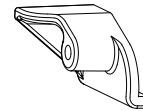

**AHW (x1)**  
Thumb Lever Extension

**METAL PARTS REQUIRED**

**METAL PARTS KIT REQUIRED: CKP**

Part shown at 8% of actual size

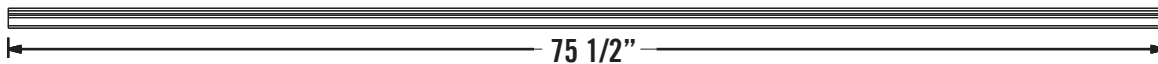

**AFC (x1)**  
Door End Channel

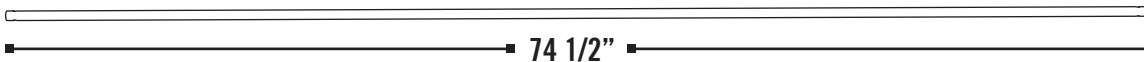
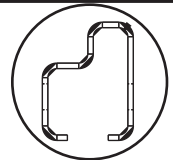

**CRE (x2)**  
Door Hinge Tube

**PLASTIC PARTS REQUIRED**

Part shown at 4% of actual size

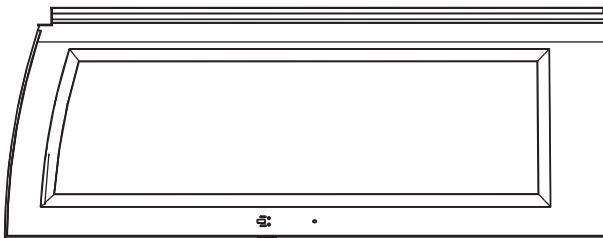

**BDK (x1)**  
Right Front Door

**TOOLS REQUIRED**

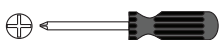

Phillips Screwdriver



7/16" Wrench



Safety Glasses



## TOOLS AND HARDWARE REQUIRED FOR THIS PAGE

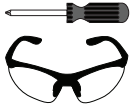

NO HARDWARE REQUIRED FOR THIS PAGE

SEC 8

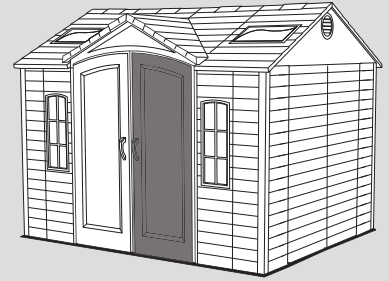

SEC

### RIGHT DOOR ASSEMBLY

8.1

Rest the **Right Shed Door (BDK)** with front side down. Slide a **Door Hinge Tube (CRE)** through the hole in the Door as shown.

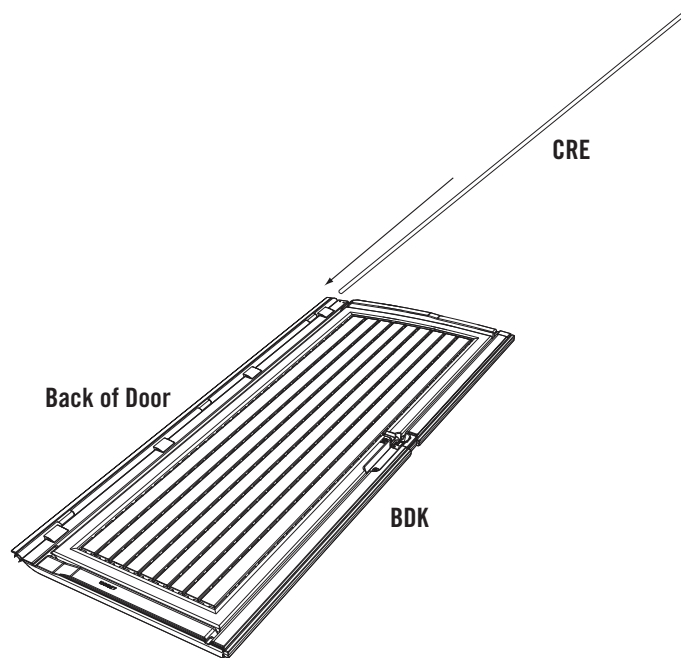

SEC

8.2

Slide the **Door End Channel (AFC)** onto the Door as shown.

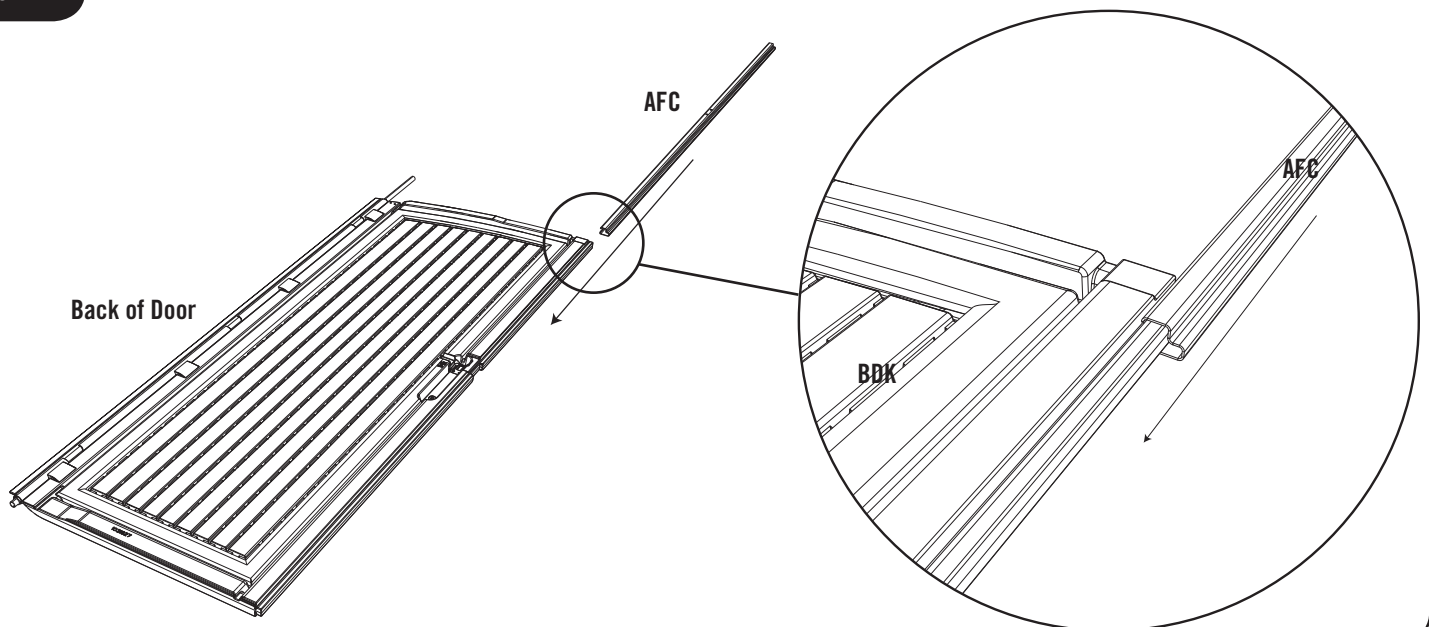



## TOOLS AND HARDWARE REQUIRED FOR THIS PAGE



NO HARDWARE REQUIRED FOR THIS PAGE

SEC. 8

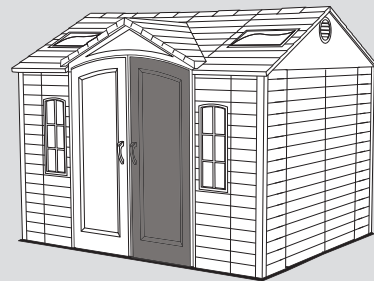

SEC

8.3

Fit knobs of the **Thumb Lever (AIO)** into the grooves of the **Right Door Handle (AIK)**.

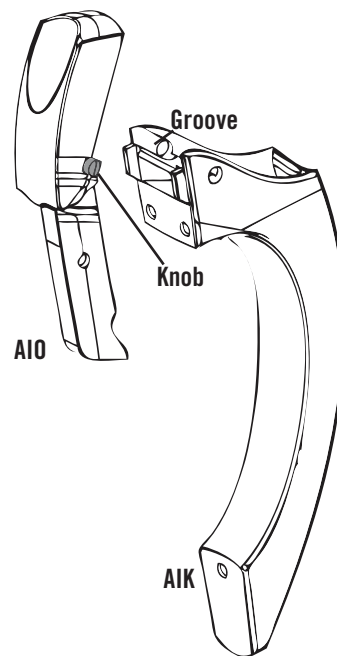

SEC

8.4

Rotate the Thumb Lever into the Right Door Handle. Slide forward until the knobs fit into the holes in the Handle.

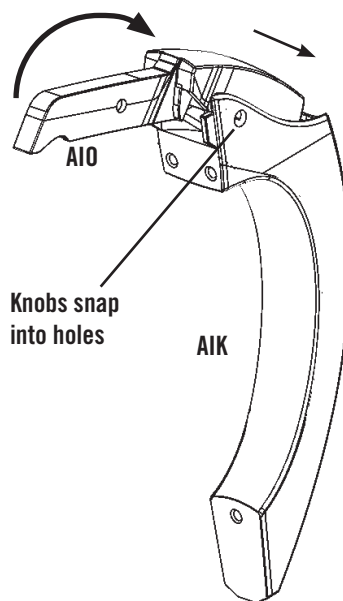



# TOOLS AND HARDWARE REQUIRED FOR THIS PAGE

SEC 8

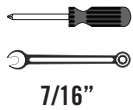

7/16"

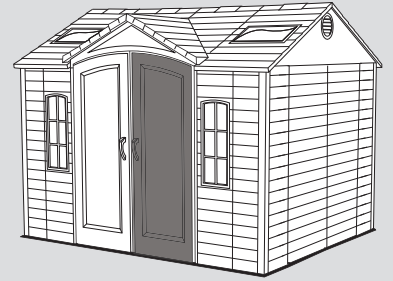
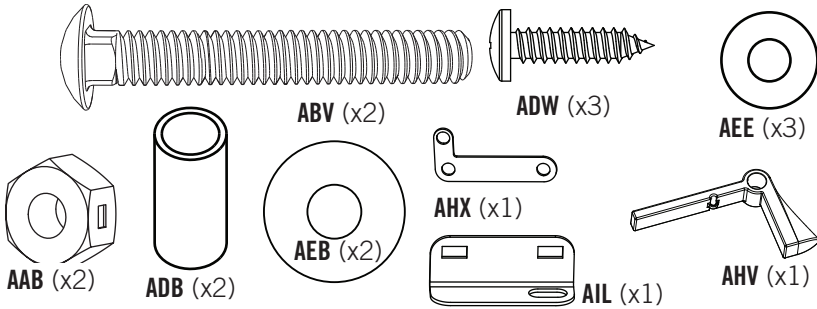

SEC

8.5

Attach the Right Handle Assembly to the Door using three (3) #10 x 1/2" Flat Washers (AEE) and three (3) #10 x 3/4" Pan-Head Screws (ADW).

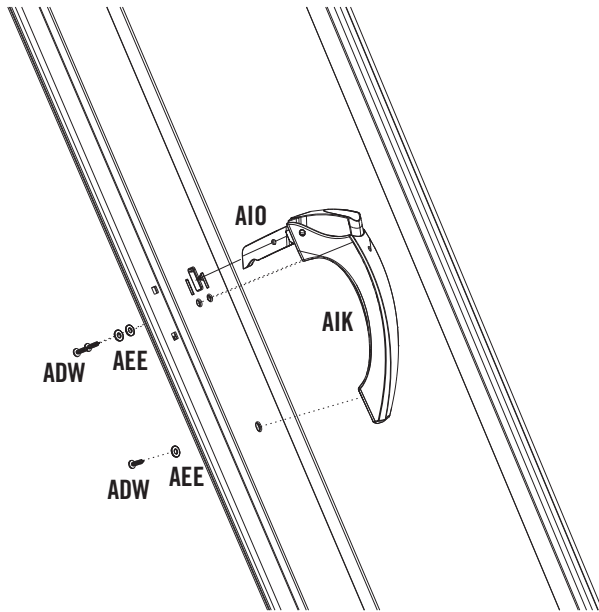

## CAUTION

Do not overtighten. Overtightening may damage parts and void warranty.

SEC

8.6

Install Handle Latch assembly onto the Right Door using the required hardware.

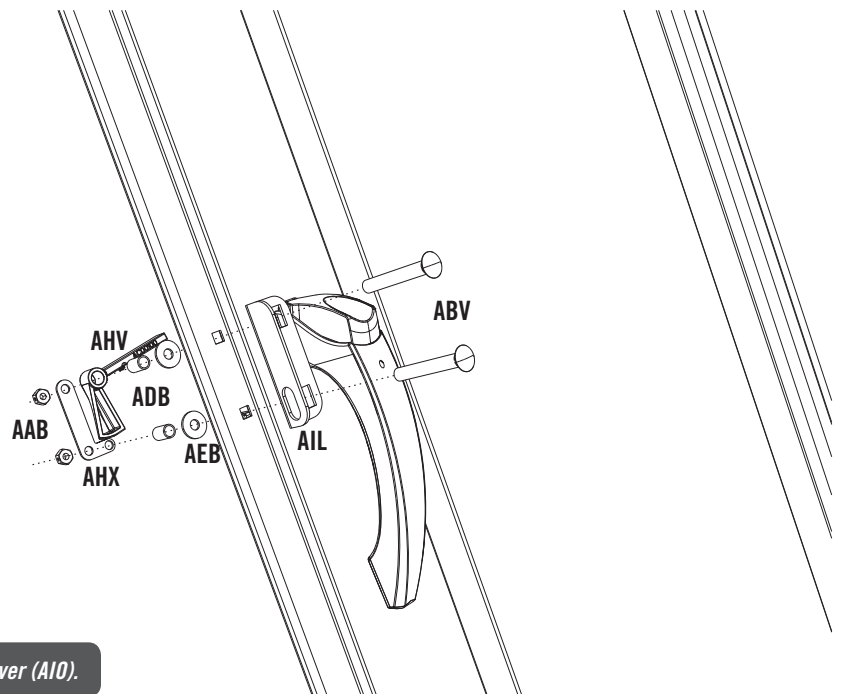
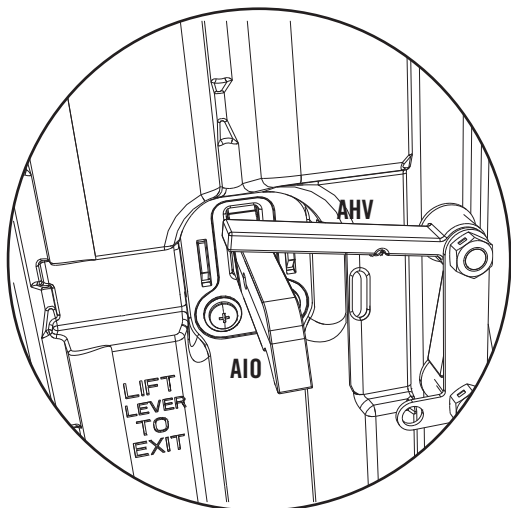

Note: The Door Latch (AHV) goes on top of the Thumb Lever (AIO).



## TOOLS AND HARDWARE REQUIRED FOR THIS PAGE

SEC. 8

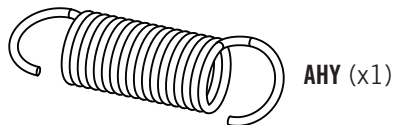

AHY (x1)

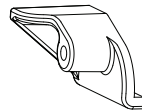

AHW (x1)

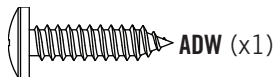

ADW (x1)

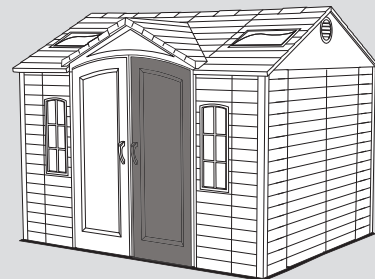

SEC

8.7

Line up the hole in the **Thumb Lever Extension (AHW)** with the hole in the Thumb Lever and **#10 x 3/4" Pan-Head Screw (ADW)** into place.



*Note: The Spring is not shown in this illustration in order to better show the correct placement of the Latch Block.*

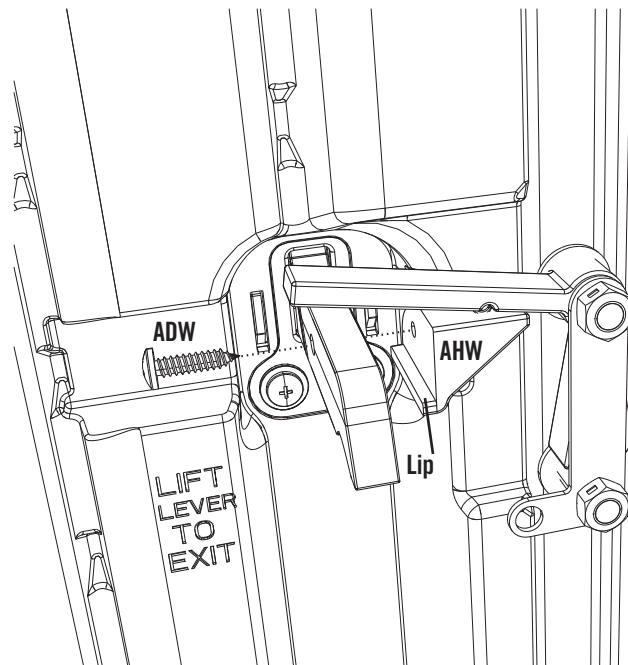

*Note: The lip of the Latch Block (AHW) fits under the Thumb Lever (AIO).*

SEC

8.8

Attach **Latch Spring (AHY)** to the **Door Latch (AHV)** and the **Latch Cover Plate (AHX)**. Set the Door aside.

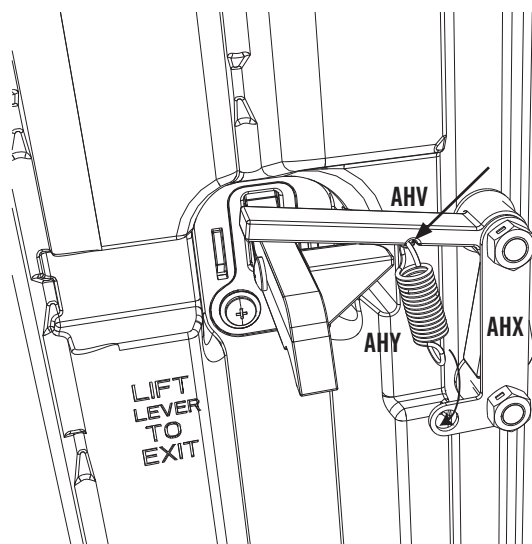

*Note: Use pliers to pull spring down and hook into bottom hole.*



## WARNING

While performing this step, each person should use protective eye glasses to help prevent serious eye injury.



**SEC 9 GABLE, TRUSS, DOOR, & ROOF INSTALLATION**

**HARDWARE REQUIRED**

Hardware shown at actual size (\*Unless noted otherwise)

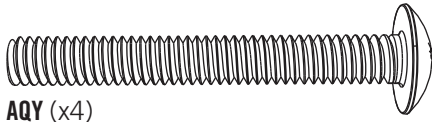

**AQY (x4)**  
1/4" x 2" Truss Screw

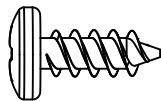

**ADZ (x160)**  
1/4" x 5/8" Pan-Head Screw  
(Not all screws will be used)

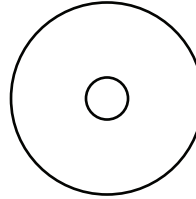

**AED (x24)**  
#10 x 1" Fender Washer



**ADJ (x4)**  
1/4" Cap Nut



**ARA (x1)** 1/8" Drill Bit

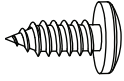

**ADX (x28)**  
#10 x 1/2" Pan-Head Screw



**AHP (x4)**  
Cotter Pin

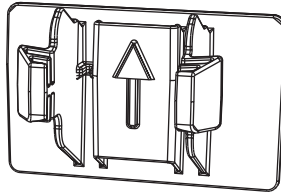

**\*AXX (x4)**  
Truss Hole Insert

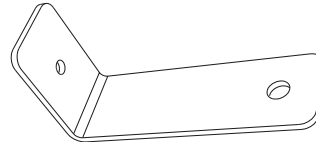

**\*AQZ (x2)**  
Entry Gable Bracket

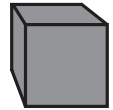

**\*AJA (x2)**  
Foam Cube

**METAL PARTS REQUIRED**

**METAL PARTS KIT & SMALL PARTS KIT REQUIRED: CKQ, CQM**

Parts shown at 8% of actual size (Unless noted otherwise)



**AFL (x8)**  
Roof Support Strip

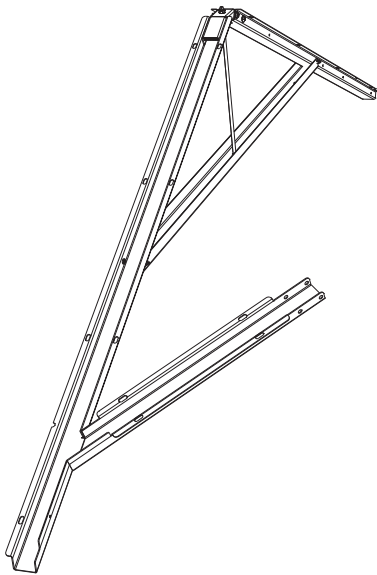

**Left Angled Truss Assembly (x1)**  
(Not shown any scale)

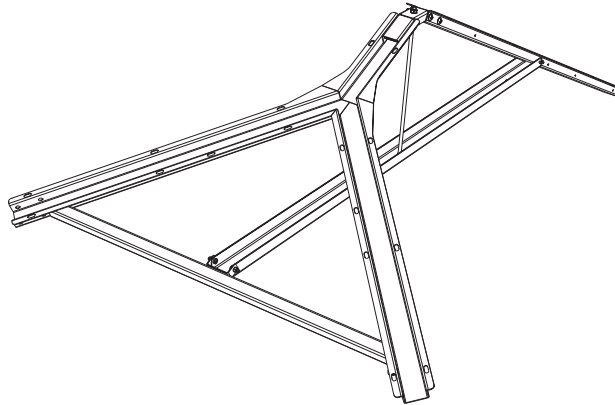

**Center Truss Assembly (x1)**  
(Not shown any scale)

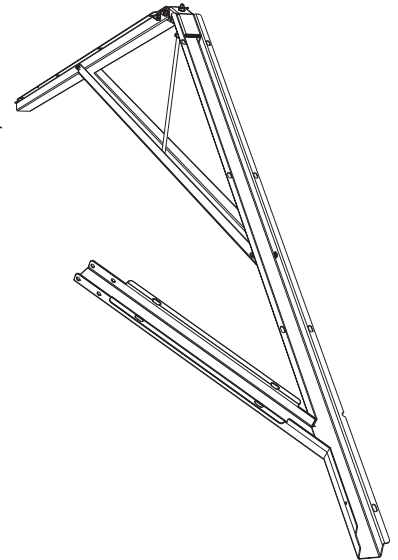

**Right Angled Truss Assembly (x1)**  
(Not shown any scale)

## PLASTIC PARTS REQUIRED

## SMALL PARTS KIT REQUIRED: CQM

Parts shown at 4% of actual size

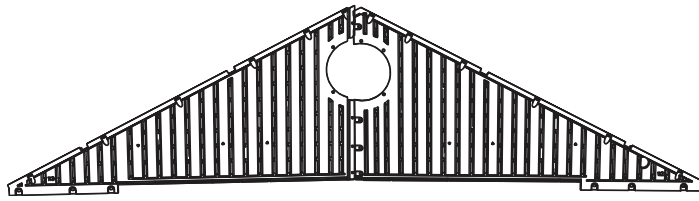

Side Gable Assembly (x2)

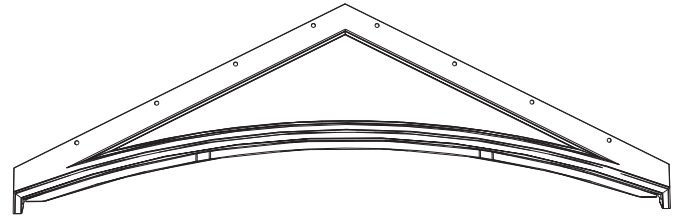

Entry Gable Assembly (x1)

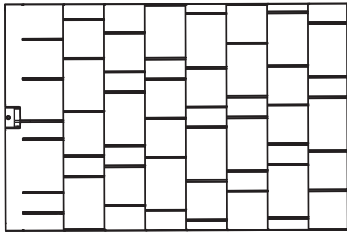

AGQ (x4)  
Roof Panel

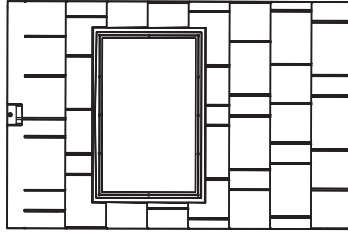

Roof Panel for Skylight Assembly (x2)

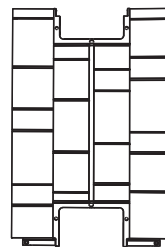

AFY (x3)  
Center Roof Cap

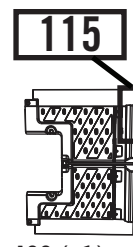

AGG (x1)  
Left End Roof Cap

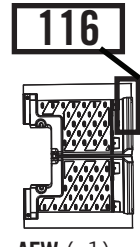

AFW (x1)  
Right End Roof Cap

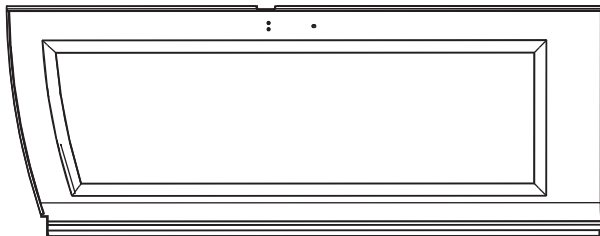

BDJ (x1)  
Left Front Door Assembly (Notched)

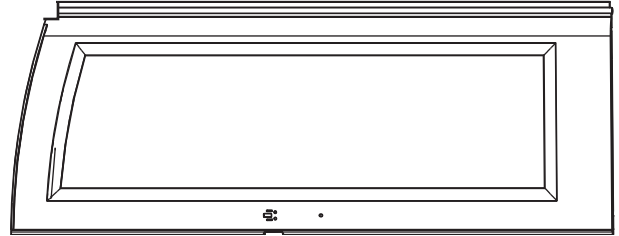

BDK (x1)  
Right Front Door Assembly (Notched)

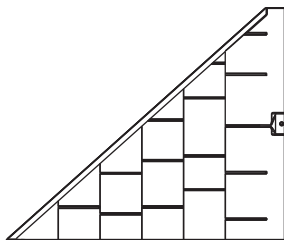

BDT (x1)  
Upper Left, Front Gable Roof Panel

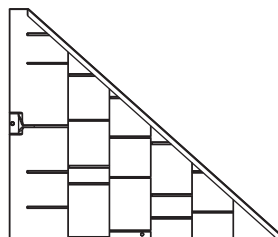

BDU (x1)  
Upper Right, Front Gable Roof Panel

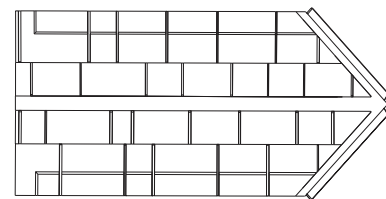

BDW (x1)  
Entry Gable Roof Cap

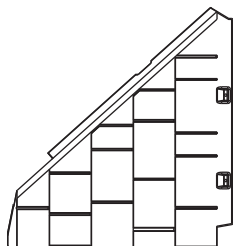

BDR (x1)  
Lower Left, Front Gable Roof Panel

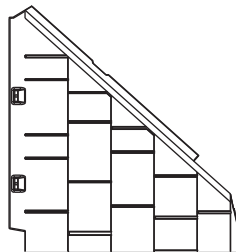

BDS (x1)  
Lower Right, Front Gable Roof Panel

Part shown at 8% of actual size

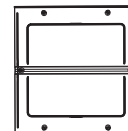

AHC (x4)  
Skylight

## TOOLS REQUIRED

## HARDWARE BAG REQUIRED: BEH

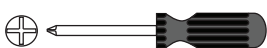

Phillips Screwdriver



Pliers



7/16"



ARA (x1) 1/8" Drill Bit (Included)



Safety Glasses



## TOOLS AND HARDWARE REQUIRED FOR THIS PAGE

SEC. 9

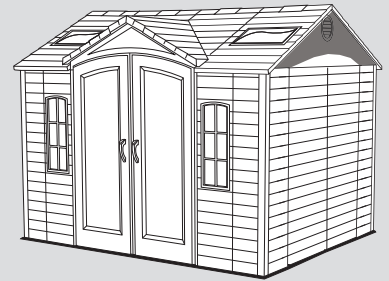

### 2 ADULTS REQUIRED FOR STEPS 9.1 - 9.2

SEC

#### SIDE GABLE INSTALLATION

9.1

Align the fourteen holes in the **Side Gable Assembly** with those along the tops of the Wall Panels on the right side of your shed.

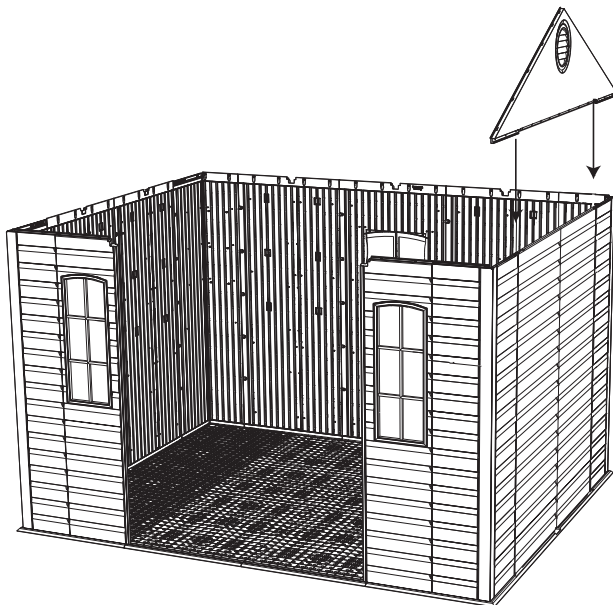

SEC

9.2

Secure the Side Gable Assembly using fourteen (14) 1/4" x 5/8" **Pan Head Screws (ADZ)** at the locations indicated.

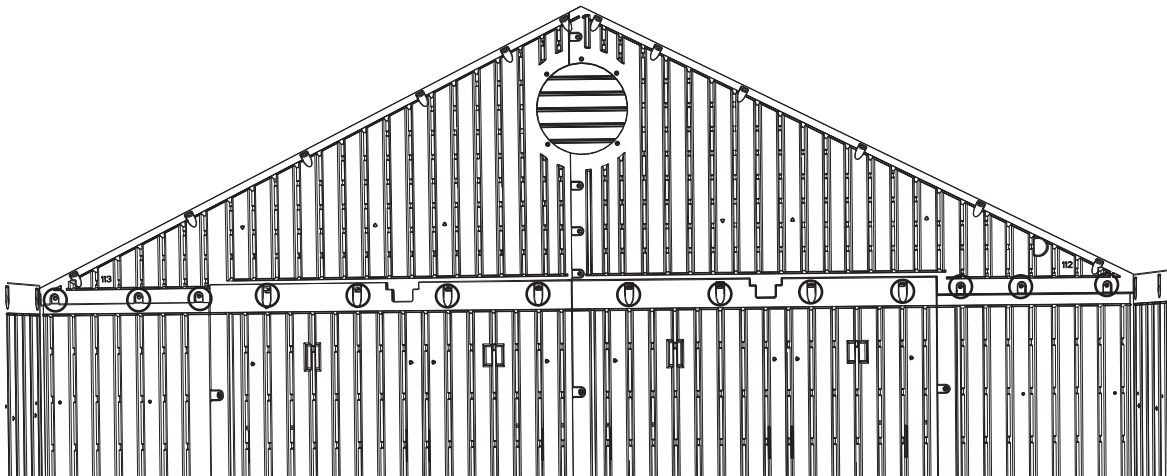



## TOOLS AND HARDWARE REQUIRED FOR THIS PAGE

SEC 9



NO HARDWARE REQUIRED FOR THIS STEP

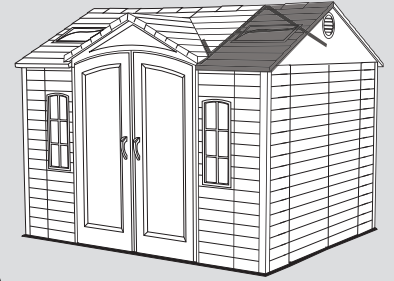

3 ADULTS REQUIRED FOR STEPS 9.3 - 9.23

SEC

### TRUSS & ROOF INSTALLATION

9.3

Place the ends of the **Right Angled Truss Assembly** into the first set of notches on the Wall Panels as shown. The angled arm faces inward.

Angled Arm

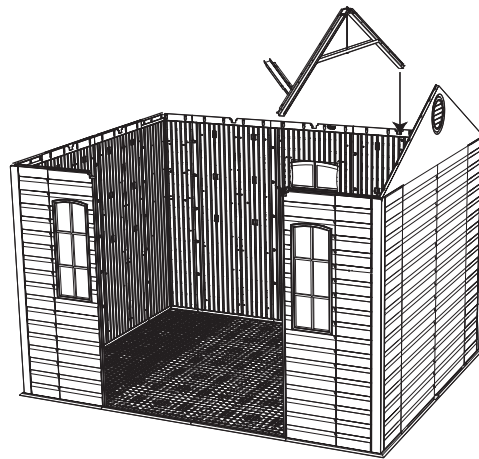
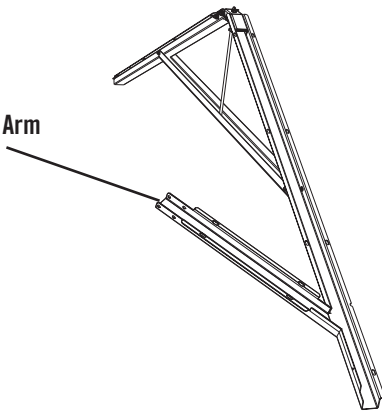

*Note: Ensure to carefully read and follow the roof installation instructions and notes. Following each step in the order listed will minimize potential complications during installation.*

SEC

9.4

While one adult holds the Right Angled Truss Assembly in place, set a **Roof Panel for Domed Skylight Assembly** onto the Right Angled Truss Assembly and Right Gable. The edge of the Roof Panel for Domed Skylight fits down inside the Truss Channels. Ensure the alignment nub in the Roof Panel fits into notch on the Truss (this helps to align the holes in the Roof Panel with those in the Truss, the Wall Panel, and Gable).

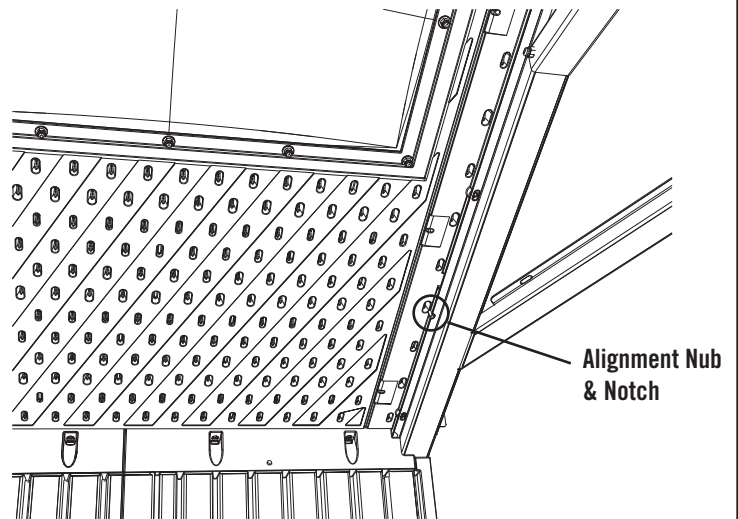
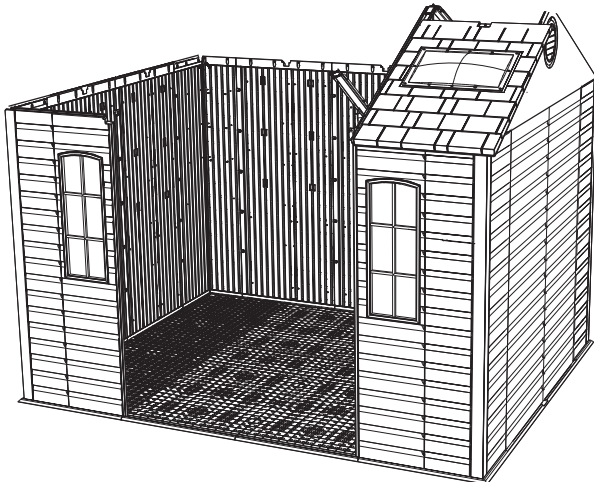

Interior Upward View



*Note: The edge of the Roof Panel fits into the Truss Assembly.*





## TOOLS AND HARDWARE REQUIRED FOR THIS PAGE

SEC. 9



(Not actual size) **AFL** (x3)

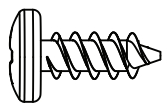

**ADZ** (x22)

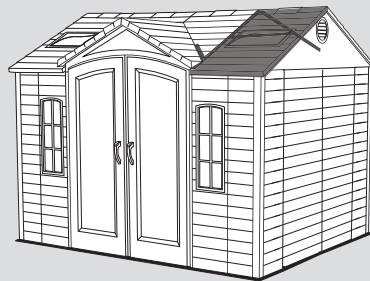

SEC

9.5

With the Roof Panel for Domed Skylight Assembly in position between the Gable and Truss, slide two (2) **Roof Supports (AFL)** into place within the notches of the Roof Panel for Domed Skylight. The bottom lip of the Roof Panels fit over the Wall Panel. The top of the Wall Panel fits into the ridge near the bottom of the Roof Panel.

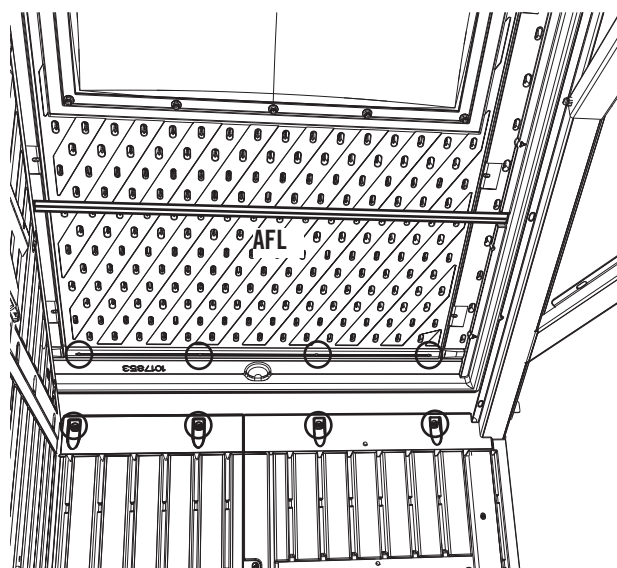
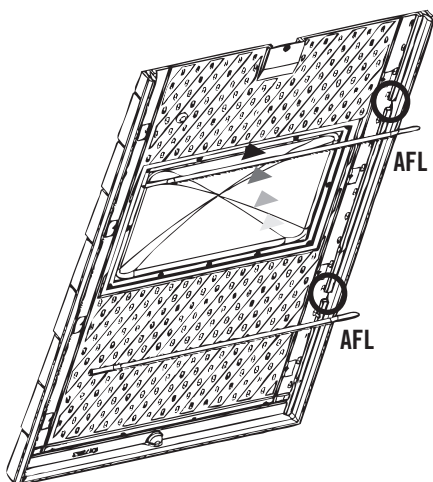

Interior Upward View



*Note: The Roof Support fits into the notches in the Roof Panel (as shown). The holes in the Roof Support Strips are for manufacturing purposes only.*

SEC

9.6

After aligning the holes in the **Roof Panel Domed for Skylight Assembly** with those in the Wall Panels, Truss, and Gable, secure the Roof Panel for Domed Skylight to the shed using the required hardware. Then, secure a Roof Panel (AGQ) to the rear of the shed. A regular Roof Panel only uses one (1) **Roof Support (AFL)**.



*Note: Use only a hand screwdriver for this step.*

AGQ

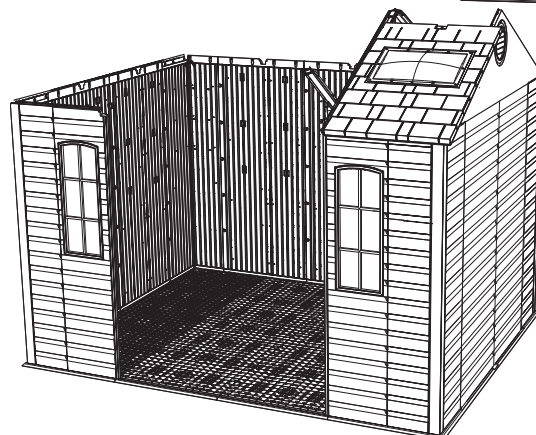
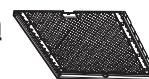

*Note: Ensure the ridge in the bottom of the Roof Panel fits into the top of the wall.*



## TOOLS AND HARDWARE REQUIRED FOR THIS PAGE

SEC 9



(Not actual size) **AFL** (x3)

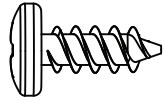

**ADZ** (x36)

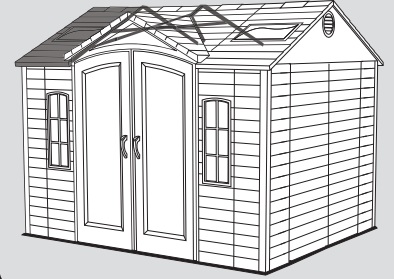

SEC

9.7

Attach a Side Gable Assembly to the left side of the shed and secure with fourteen (14) 1/4" x 5/8" Pan-Head Screws (**ADZ**) as you did in steps 9.1 - 9.2. Follow steps 9.3 - 9.6 to install the **Left Angled Truss Assembly**, a **Roof Panel for Domed Skylight Assembly**, **Roof Panel (AGQ)**, and **Roof Supports (AFL)** on the left side of the shed.

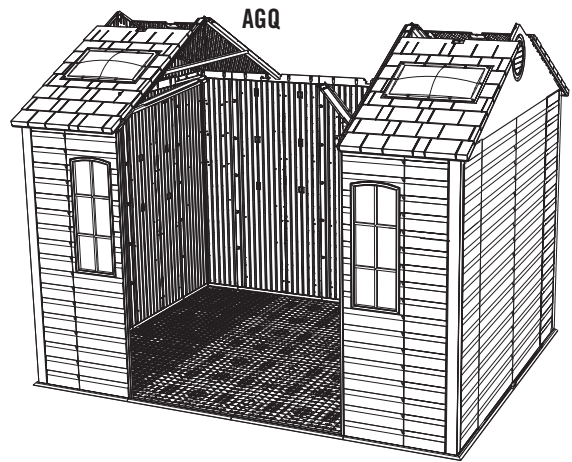
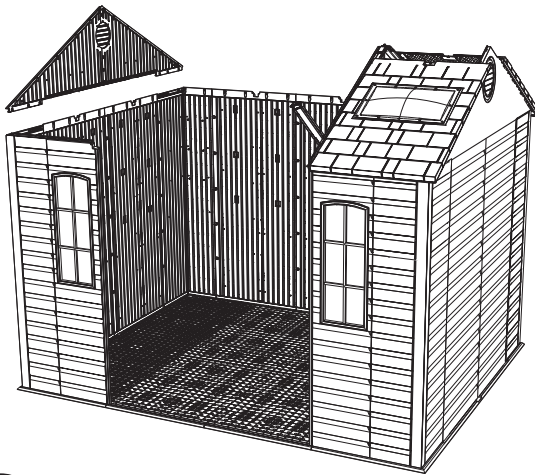

SEC

9.8

Set the back end of the **Center Truss Assembly** into the notch in the center of the rear Wall and the front, angled ends into the Left and Right Angled Truss Assemblies.

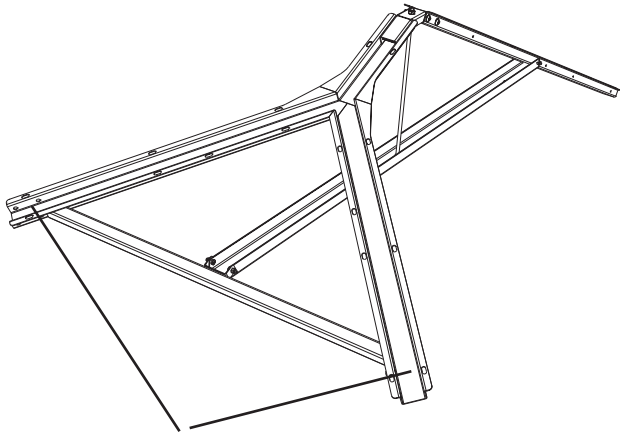

Angled Arms

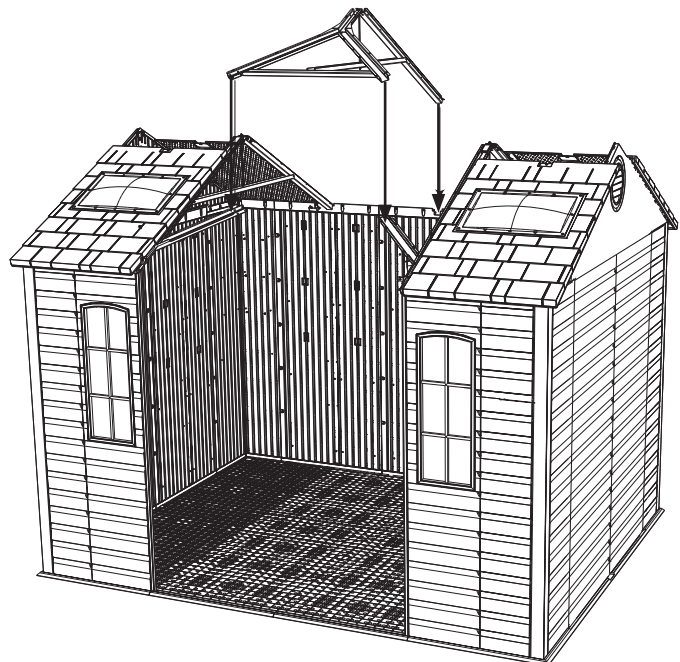





## TOOLS AND HARDWARE REQUIRED FOR THIS PAGE

SEC. 9



7/16"



ADJ (x4)

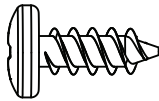

ADZ (x20)



(Not actual size) AFL (x2)



AQY (x4)

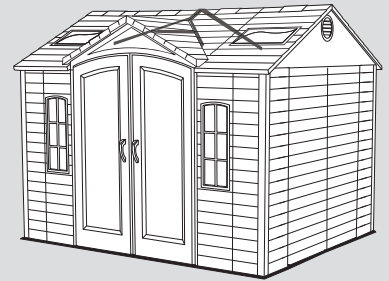

SEC

9.9

With the front arms of the Center Truss Assembly in the angled arms of the Left and Right Angled Truss Assemblies, secure the **Center Truss Assembly** to the Left and Right Angled Truss Assemblies using the required hardware. Tighten hardware securely.

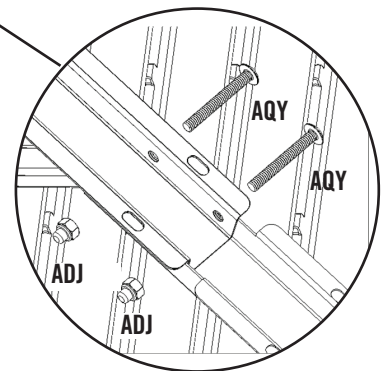
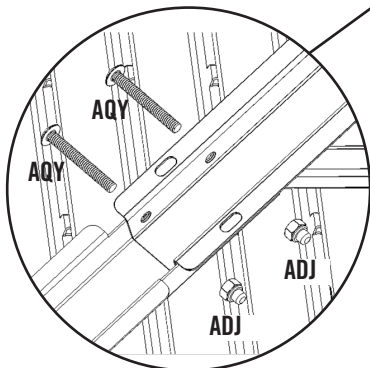
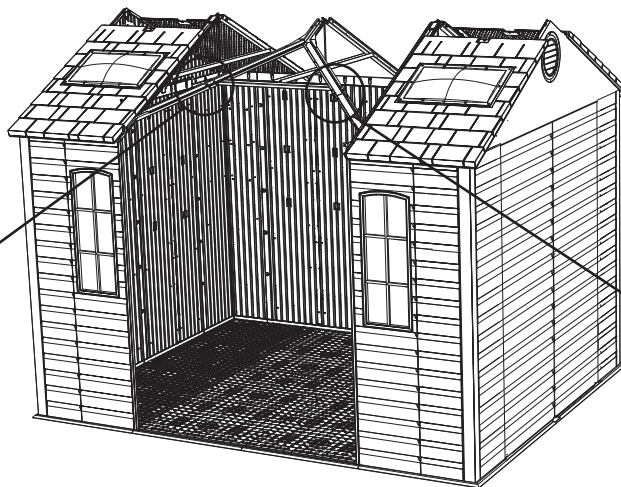

SEC

9.10

Install the remaining **Roof Panels (AGQ)** and **Roof Supports (AFL)** to the rear of the shed using twenty (20) 1/4" x 5/8" **Pan-Head Screws (ADZ)**. The Roof Panels fit down inside the Truss Gutter Channels.

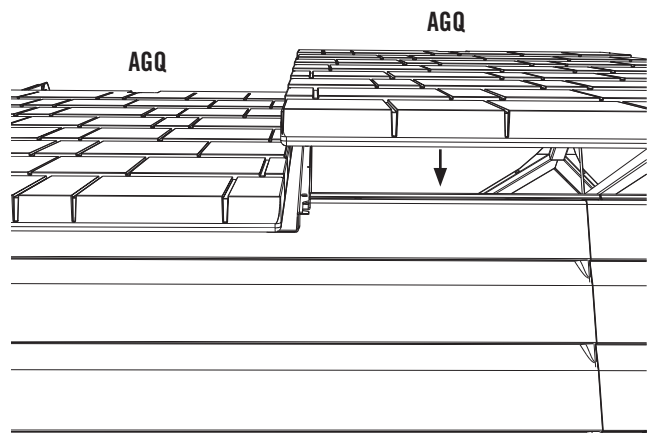
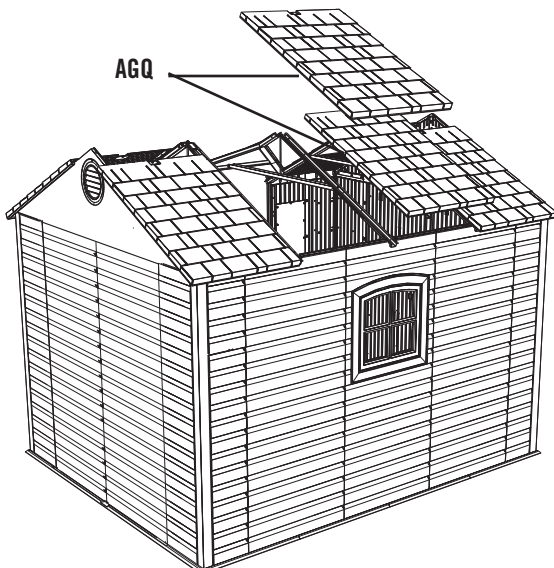

Rear of Shed



*Note: Roof Panels butt up against each other inside the Truss Gutter Channels.*



## TOOLS AND HARDWARE REQUIRED FOR THIS PAGE

SEC 9

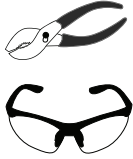

AHP (x2)

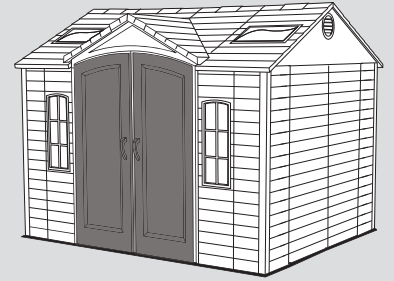

SEC

9.11

### DOOR & ENTRY GABLE INSTALLATION

Insert the hinge tube of the **Left, Front Door Assembly** into the left, front Door Hinge Bushing as shown. Ensure bottom of Hinge fits completely into the Door Hinge Bushing.

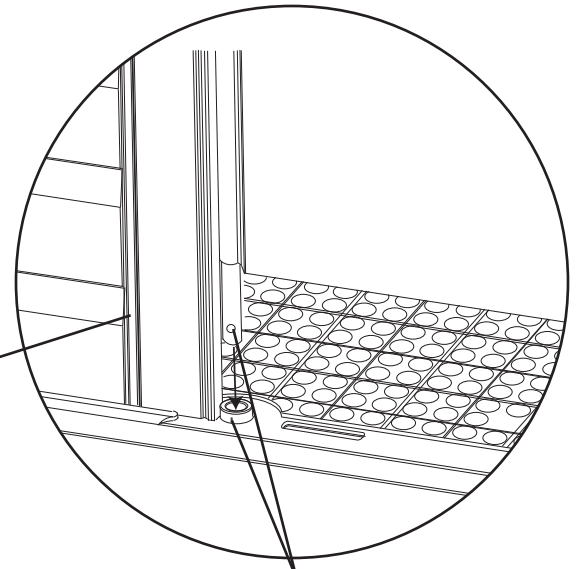
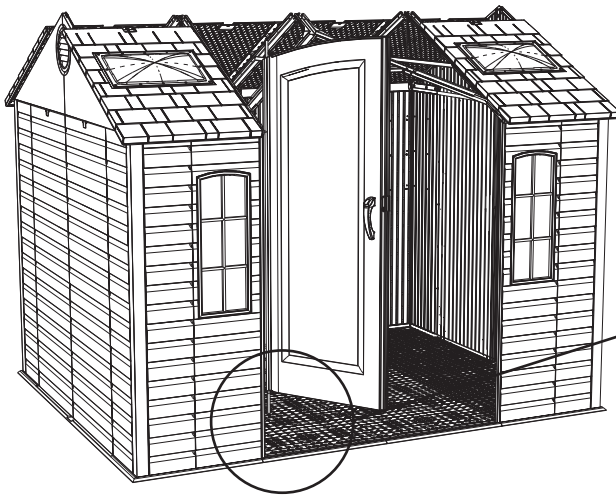

*Note: Ensure that these two holes line up, so that the Cotter Pin (AHP) can be inserted.*

SEC

9.12

Insert a **Cotter Pin (AHP)** through the Bushing and Door Hinge. Use a pair of pliers to bend the ends of the Cotter Pins outward. **Repeat steps 9.11 & 9.12 for the Right, Front Door Assembly (Notched).**

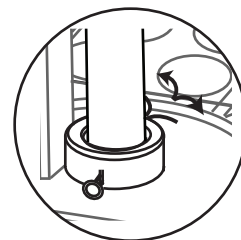
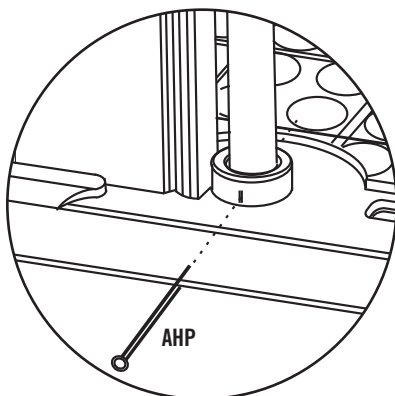

*Note: Use pliers to bend back the ends of the Cotter Pin (AHP).*



## TOOLS AND HARDWARE REQUIRED FOR THIS PAGE

SEC. 9

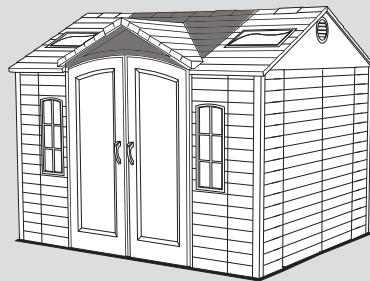

SEC

9.13

While another adult holds the Doors in place, slide the **Entry Gable Assembly** over the Door Hinges. The tops of the hinges will fit into the holes on each end of the Gable.

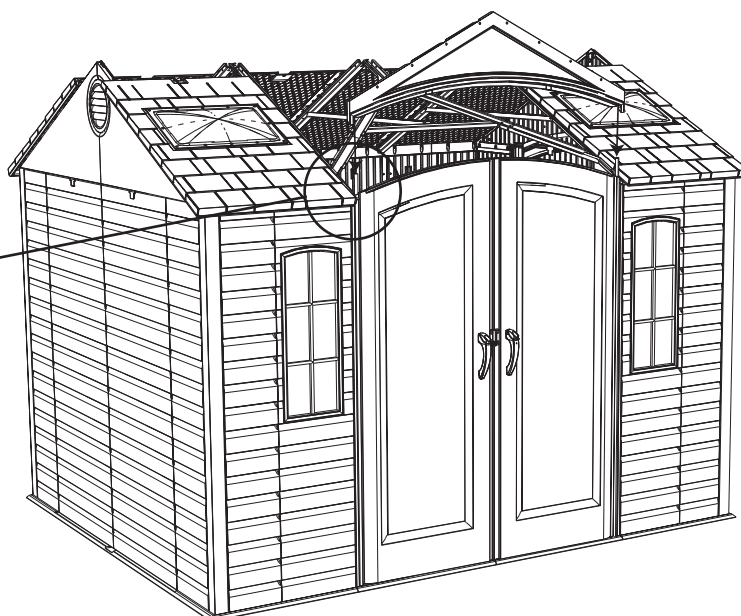
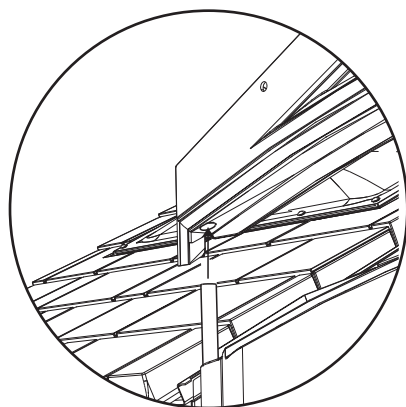

SEC

9.14

Attach the **Upper Left** and **Right Front Gable Roof Panels (BDT & BDU)** using seven (7) 1/4" x 5/8" Pan-Head Screws (ADZ) per Panel at the locations indicated.

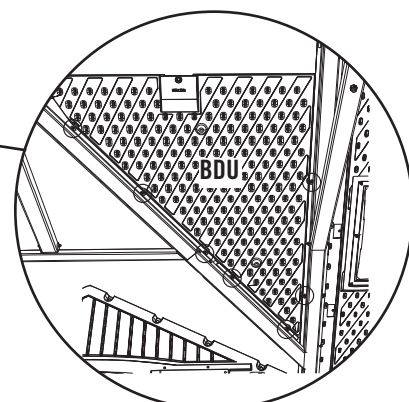
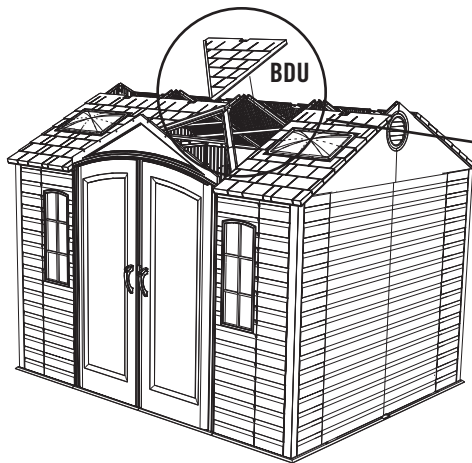
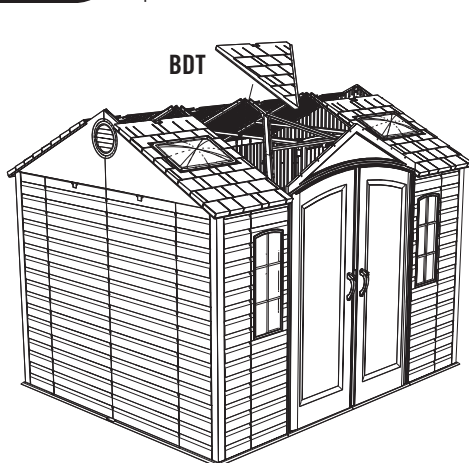

Interior Upward View





# TOOLS AND HARDWARE REQUIRED FOR THIS PAGE

SEC 9

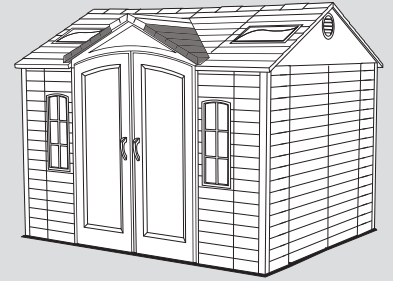

SEC

9.15

Align the holes in the **Lower Left Front Gable Roof Panel (BDR)** with those in the Angled Truss and Front Gable Assemblies and secure with the required hardware. Repeat this step for the **Lower Right Front Gable Roof Panel (BDS)**.

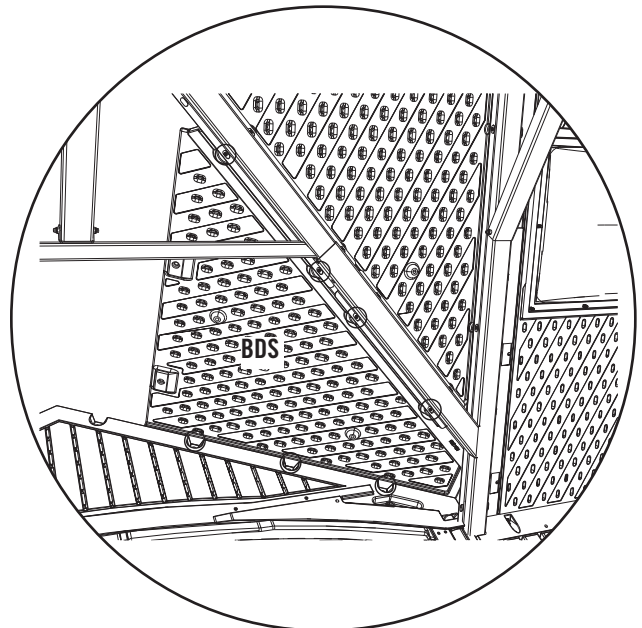
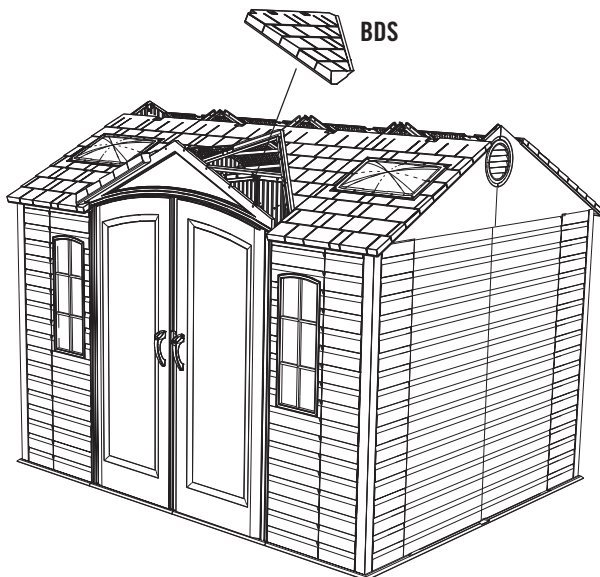
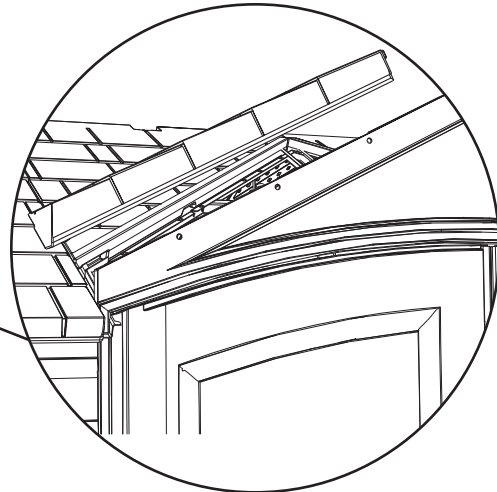
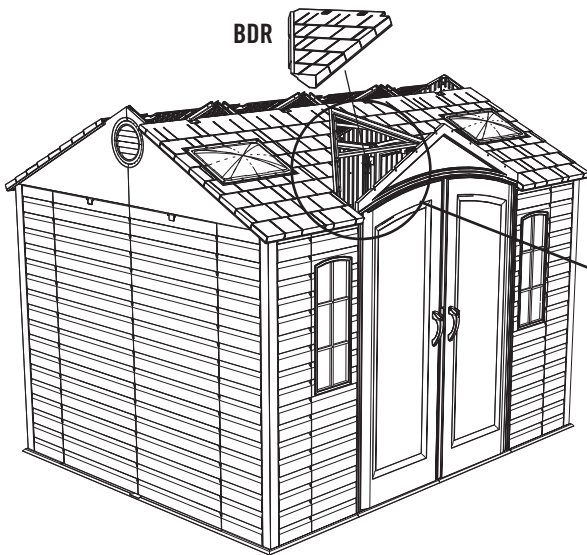

Interior Upward View



## TOOLS AND HARDWARE REQUIRED FOR THIS PAGE

SEC. 9

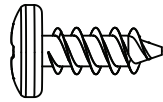

ADZ (x10)

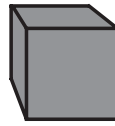

AJA (x2)  
(Not to scale)

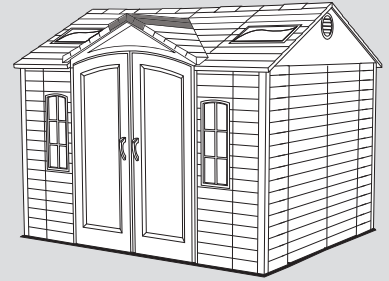

SEC

9.16

Insert two **Foam Cubes (AJA)** inside the Center Truss Assembly at the location shown. The purpose of the Foam Cubes is to block light entering at this point.

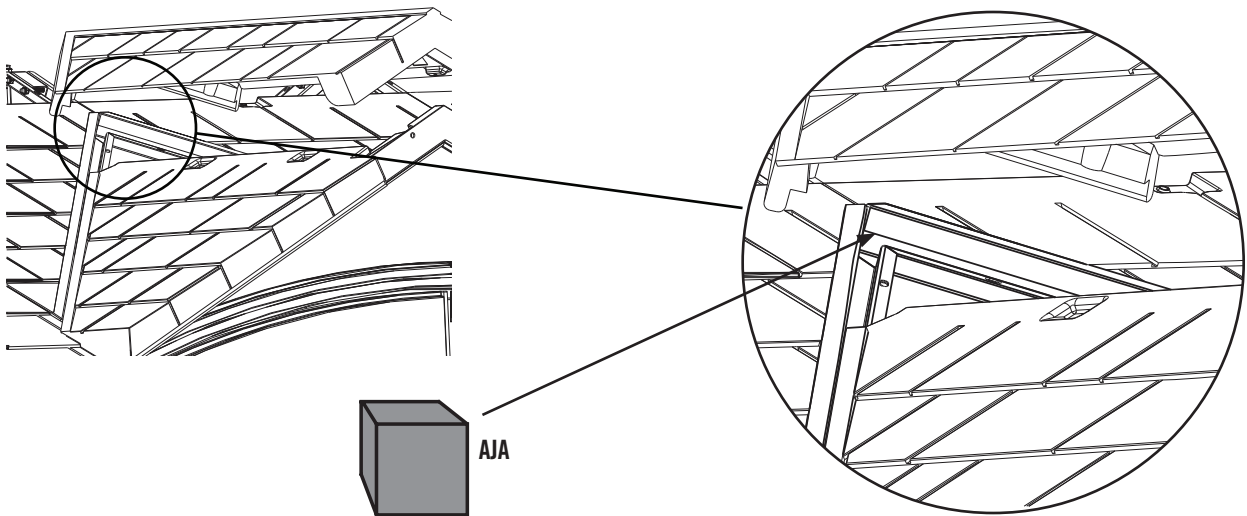

SEC

9.17

Attach the **Entry Gable Roof Cap (BDW)** at the locations indicated using the required hardware.

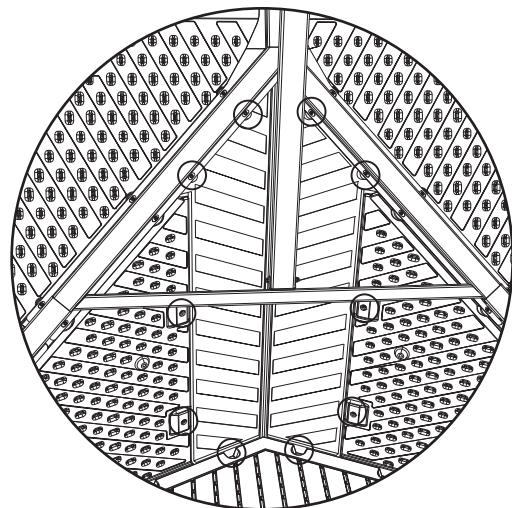
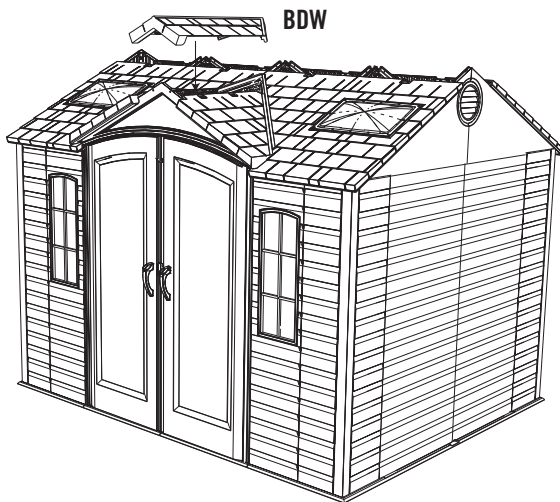

Interior Upward View



*Note: Attach the Roof Cap to the Panels and the Gable at the locations shown.*



## TOOLS AND HARDWARE REQUIRED FOR THIS PAGE

SEC 9

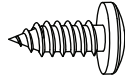

ADX (x4)



ARA (x1)

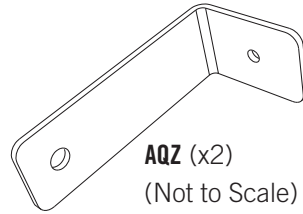

AQZ (x2)  
(Not to Scale)

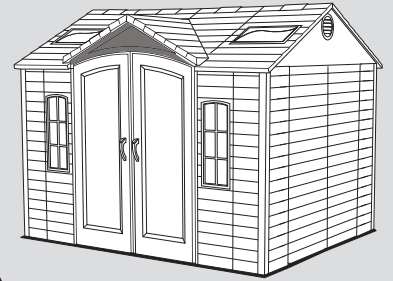

SEC

9.18

Loosely attach the **Entry Gable Bracket (AQZ)** to the Truss at the location shown with a **Screw (ADX)**. Turn the Entry Gable Bracket into position and use the hole as a guide for the **1/8" Drill Bit (ARA)**. Carefully drill through the Gable and into the Door Hinge (be sure that the bit goes into the Hinge Tube but not all the way through).

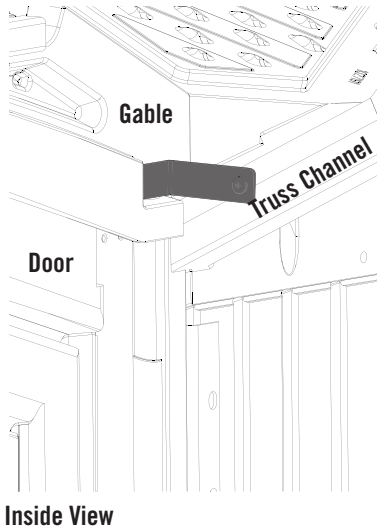
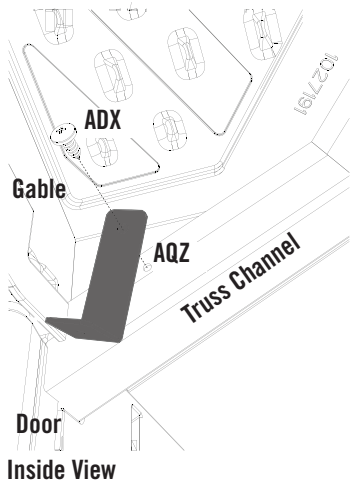

### WARNING

While performing this step, each person should use protective eye glasses to help prevent serious eye injury.



### CAUTION

Do not drill all the way through the Gable. Only drill into the Hinge Tube.

SEC

9.19

Insert two (2) **#10 x 1/2" Pan-Head Screws (ADX)** through the Bracket and into the Gable and Door Hinge. **Repeat** steps 9.20 - 9.21 for the other end of the Front Entry Gable.

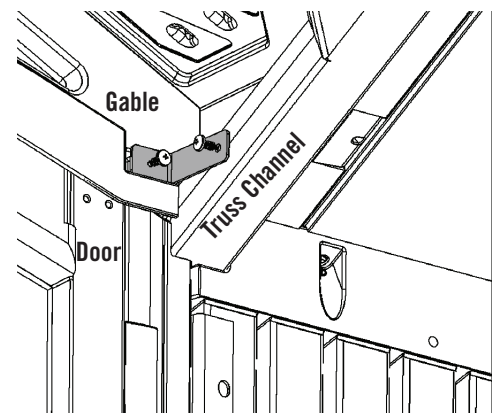

Inside View



*Note: The front of the Panel fits over the Gable.*





## TOOLS AND HARDWARE REQUIRED FOR THIS PAGE

SEC. 9

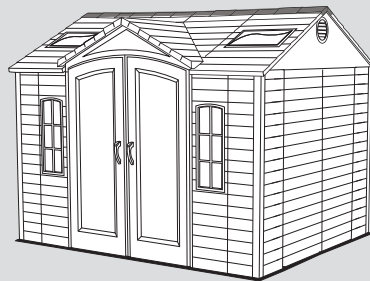

SEC

9.20

Starting at the left side of your shed, attach the **Left End Roof Cap (AGG)** to the Roof Panels and Left Side Gable. Continue moving to the right attaching the **Center Roof Caps (AFY)**. Finally attach the **Right End Roof Cap (AFW)** to the Roof Panels and Gable.



*Note: Use only a hand screwdriver for this step.*

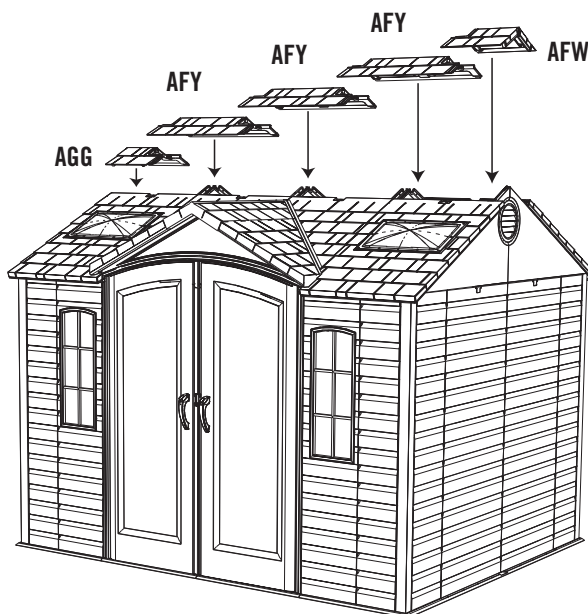

**CAUTION**

Only hand tighten screws. Do not overtighten. Overtightening may damage plastic parts and void warranty.

SEC

9.21

Connect the Roof Caps to each other using **1/4" x 5/8" Pan-Head Screws (ADZ)**.

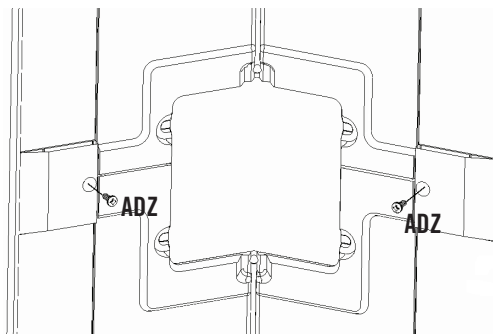



## TOOLS AND HARDWARE REQUIRED FOR THIS PAGE

SEC 9

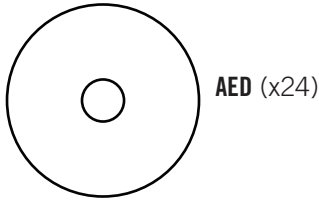

AED (x24)



ADX (x24)

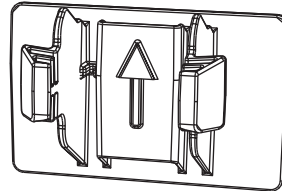

AXX (x2)  
(Not to scale)

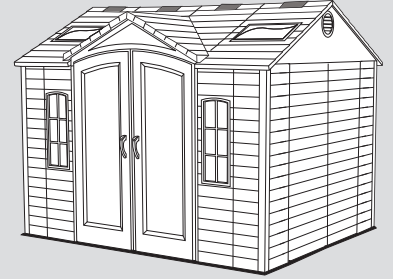

SEC

9.22

### SKYLIGHT INSTALLATION

Pre-fold **Skylight (AHC)** before installing. Push folded Skylight up through opening between Roof Caps; open Skylight; use tabs to pull Skylight down into place. Fasten Skylight in place with **#10 x 1" Fender Washers (AED)** and **#10 x 1/2" Pan-Head Screws (ADX)** (pull down on tabs while inserting screw to provide resistance). Repeat this step for each Skylight.

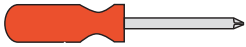

Note: Use only a hand screwdriver for this step.

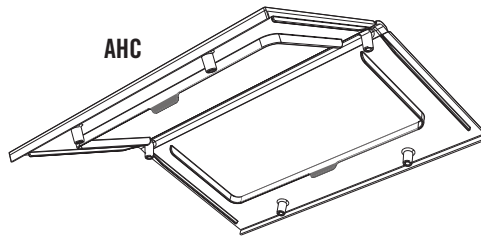

AHC

AHC AHC AHC AHC

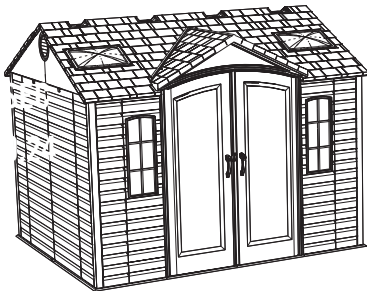

Pull down on tabs while inserting screws.

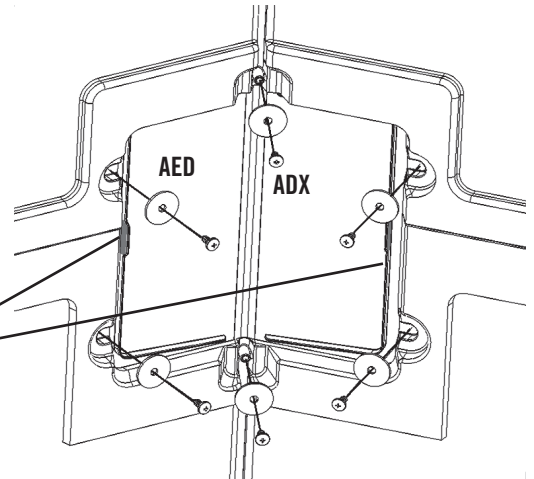

SEC

9.23

### GABLE CLIP INSERTION

Insert the **Truss Hole Inserts (AXX)** into the side walls as shown.

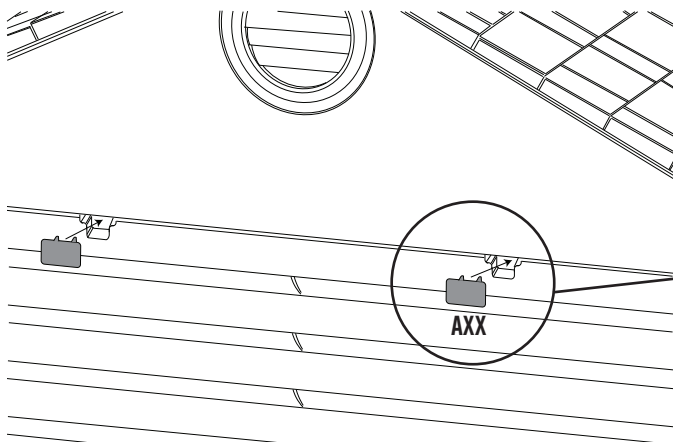

AXX

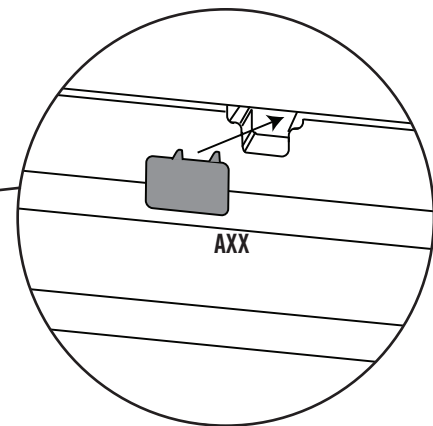

AXX



Note: Gable Clip can only be inserted with the arrow pointing up.

# SEC 10 SHELF INSTALLATION

## HARDWARE REQUIRED

Hardware shown at actual size

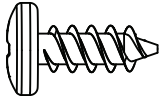

**ADZ** (x28)  
1/4" x 5/8" Pan-Head Screw

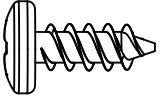

**ADZ** (x8)  
1/4" x 5/8" Pan-Head Screw

## HARDWARE BAG REQUIRED: BHH (x2), BHI (x2)

Part shown at 15% of actual size



**AIY** (x4)  
Shelf Bracket

## METAL PARTS REQUIRED

Part shown at 8% of actual size

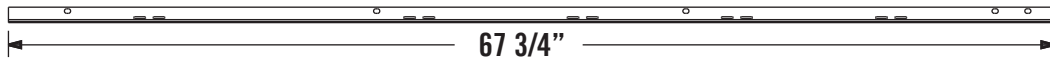

**AFM** (x4)  
Shelf Support Channel

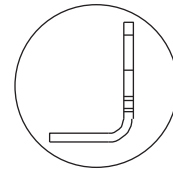

## METAL PARTS KIT REQUIRED: CKP

## PLASTIC PARTS REQUIRED

Part shown at 4% of actual size



**AFV** (x2)  
90" Shelf

## SMALL PARTS KIT REQUIRED: CQM

Part shown at 8% of actual size

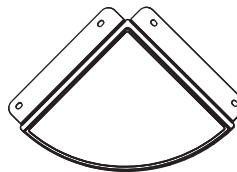

**AFZ** (x2)  
Corner Shelf

## TOOLS REQUIRED

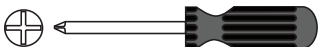

Phillips Screwdriver



Safety Glasses



## TOOLS AND HARDWARE REQUIRED FOR THIS PAGE

SEC 10

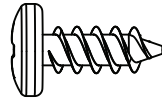

ADZ (x16)

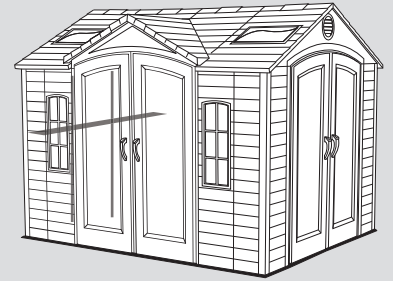

SEC

10.1

### SHELF SUPPORT CHANNEL INSTALLATION

Insert a **Shelf Support Channel (AFM)** into the slots in the Wall Panels directly below the Right Truss notch on the left side of your shed, and secure with four (4) **1/4" x 5/8" Pan-Head Screws (ADZ)**. Insert a second Shelf Support Channel in the slot directly to the right of the Left Truss Notch and secure with four (4) **1/4" x 5/8" Pan-Head Screws**.

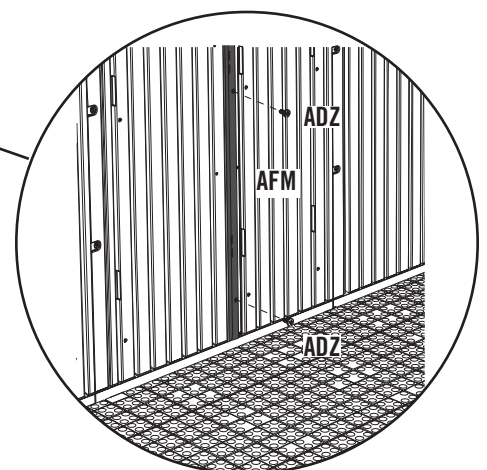
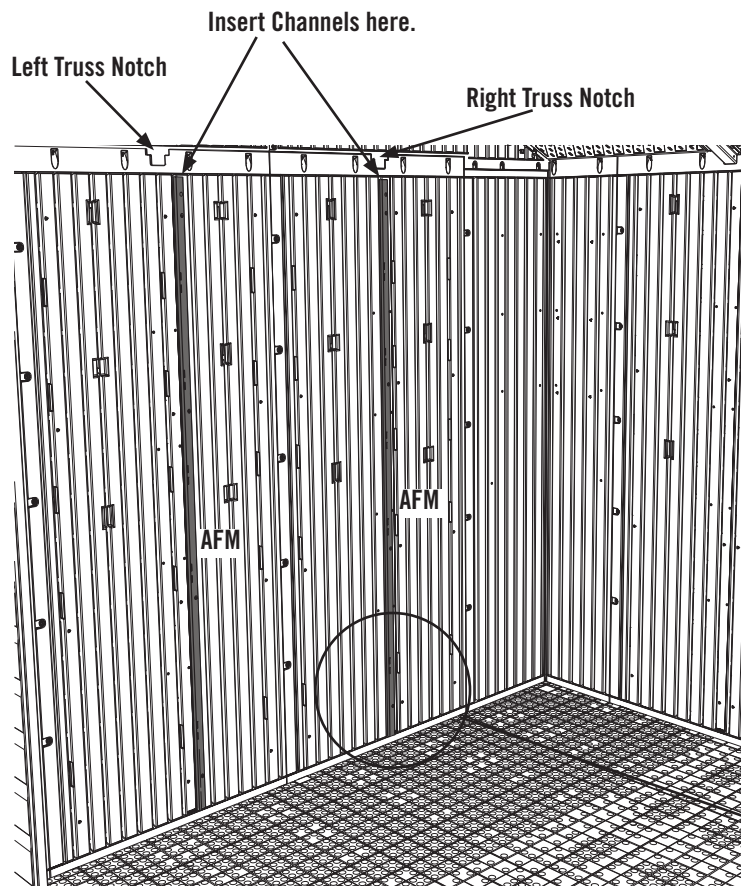



## TOOLS AND HARDWARE REQUIRED FOR THIS PAGE

SEC. 10

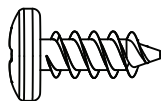

ADZ (x12)

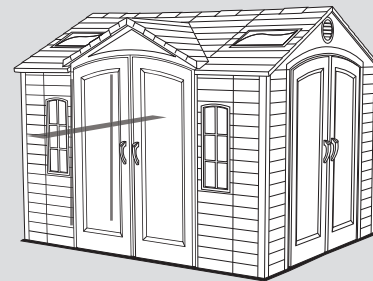

SEC

10.2

### 90" SHELF INSTALLATION

Set a **Shelf Support Bracket (AIY)** into the slots of each of the Shelf Support Channels. The slots must be at the same height.

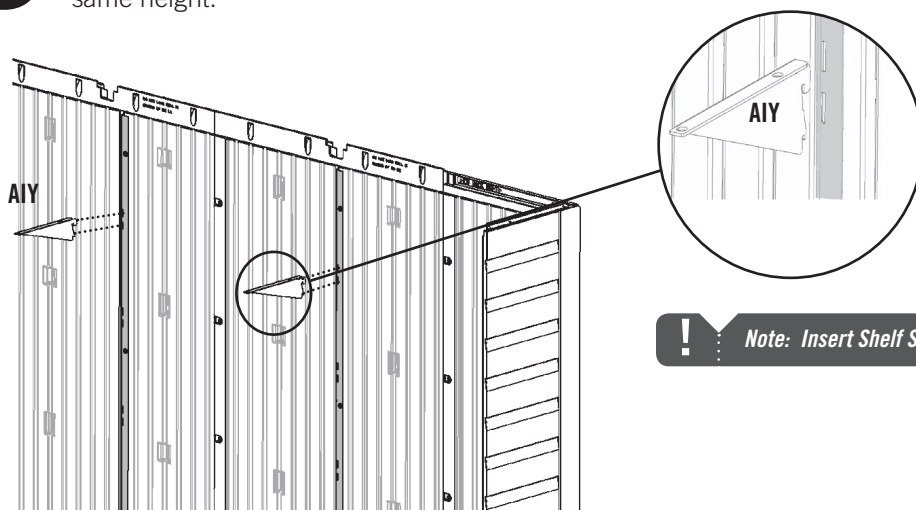

*Note: Insert Shelf Support Bracket at an angle.*

SEC

10.3

Fold up flaps on the end of **90" Shelf (AFV)**. Set Shelf on Brackets with indentations toward wall, and secure with six (6) **1/4" x 5/8" Phillips Pan-Head Screws (ADZ)**. Repeat this section for the second 90" Shelf for the right side of the shed.

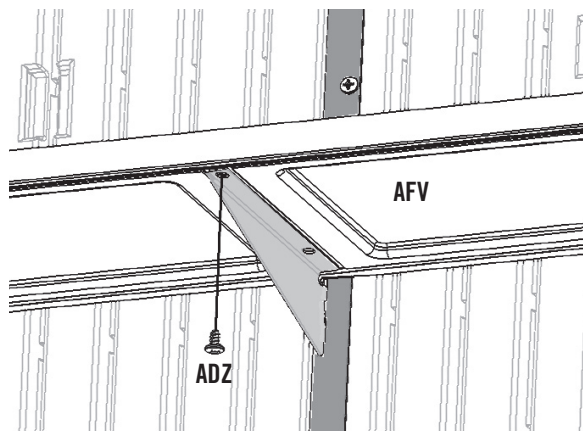

Upward view

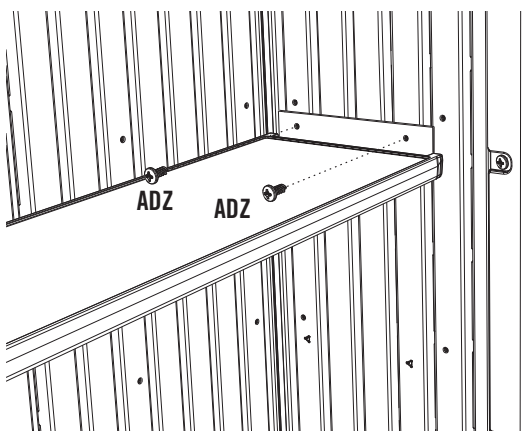

### WARNING

The weight limit for a 90" Shelf is 30 lb. per 30" section of Wall Panel. Failure to heed this warning could result in property damage and/or personal injury.



*Note: There are only holes for screws along front side of the Shelf (front is labeled "Front" on underside of Shelf).*





## TOOLS AND HARDWARE REQUIRED FOR THIS PAGE

SEC 10

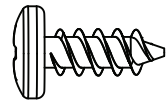

ADZ (x8)

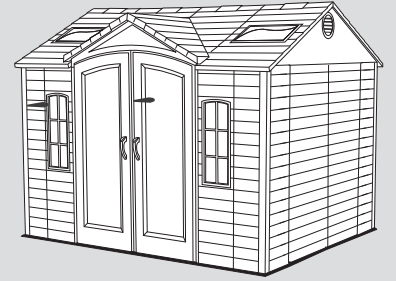

SEC

10.4

### CORNER SHELF INSTALLATION

Note the top set of pre-made holes in the corners of the shed (Fig. 1). Any of these holes may be used for a **Corner Shelf (AFZ)**. Fold up edges of a Corner Shelf. Line-up the holes in the Corner Shelf with the top set of pre-made holes in any corner Wall Panel (Fig. 2). Secure with four (4) **1/4" x 5/8" Phillips Pan-Head Screws (ADZ)**. Repeat this step for the second Corner Shelf.

Holes

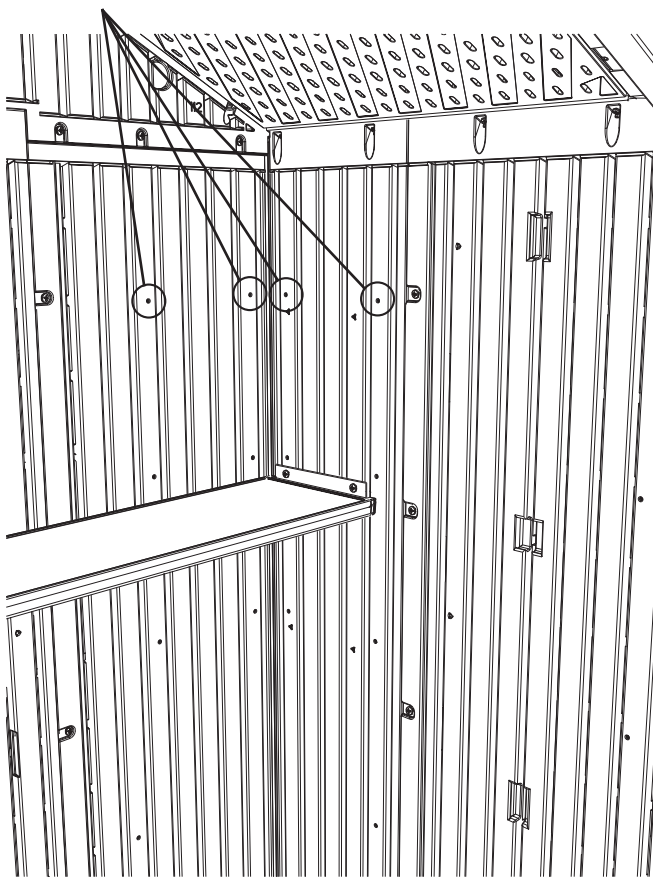

Fig. 1

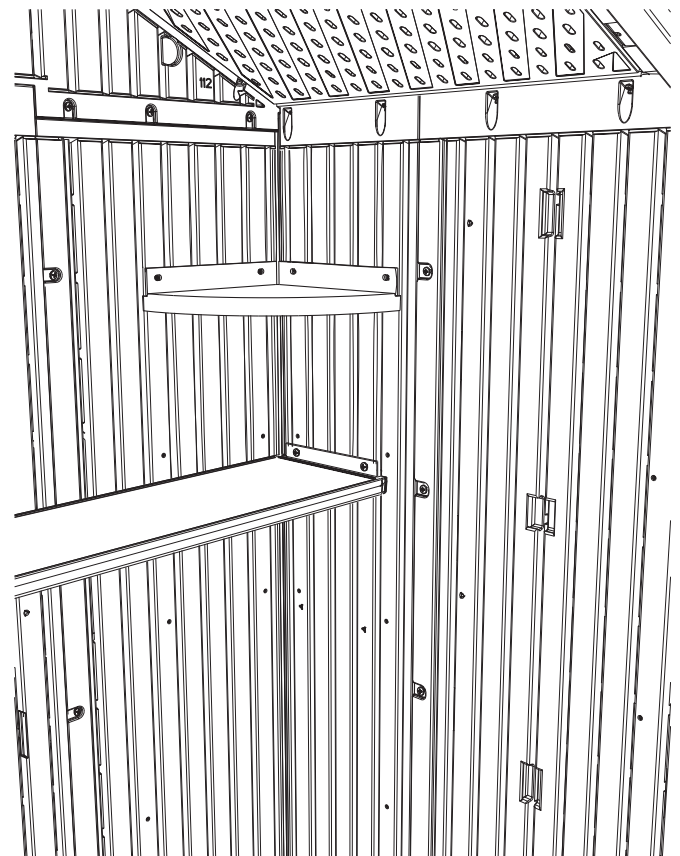
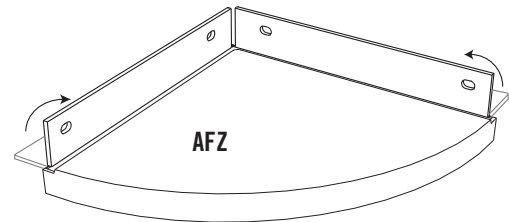

Fig. 2



### WARNING

The weight limit for a Corner Shelf is 10 lb. per Shelf. Failure to heed this warning could result in property damage and/or personal injury.



**SEC 11 WINDOW INSTALLATION**

**HARDWARE REQUIRED**

**HARDWARE BAG REQUIRED: BEI**

Hardware shown at actual size

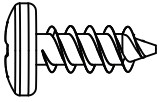

**ADZ** (x4)  
1/4" x 5/8" Pan-Head Screw

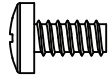

**ADY** (x1)  
#10 x 3/8" Pan-Head Screw

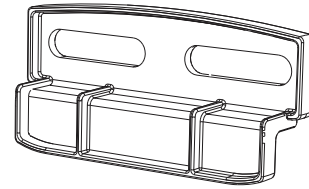

**AIS** (x2)  
Window Latch

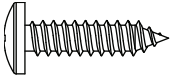

**ADW** (x28)  
#10 x 3/4" Pan-Head Screw

**METAL PARTS REQUIRED**

**NO METAL PARTS REQUIRED FOR THIS SECTION**

**PLASTIC PARTS REQUIRED**

**SMALL PARTS KIT REQUIRED: CQM**

Part shown at 4% of actual size

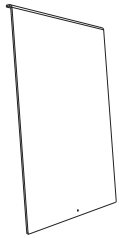

**AHE** (x1)  
Window



**BDV** (x2)  
Half-Wall Window

**TOOLS REQUIRED**

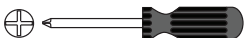

**Phillips Screwdriver**



**Safety Glasses**



## TOOLS AND HARDWARE REQUIRED FOR THIS PAGE

SEC 11

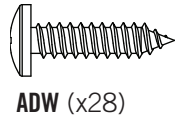

ADW (x28)

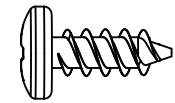

ADZ (x4)

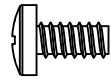

ADY (x1)

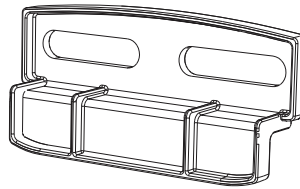

AIS (x2)

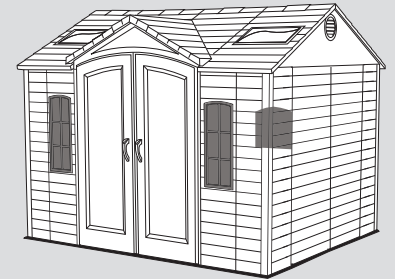

SEC

11.1

Remove the plastic protective film from **both sides** of the **Window for Half-Window Wall Panel (BDV)** and attach the Window for Half-Window Wall Panel to the Right Half-Window Wall Panel using fourteen (14) **#10 x 3/4" Pan-Head Screws (ADW)**. Repeat this step for the Left Half-Window Wall Panel.

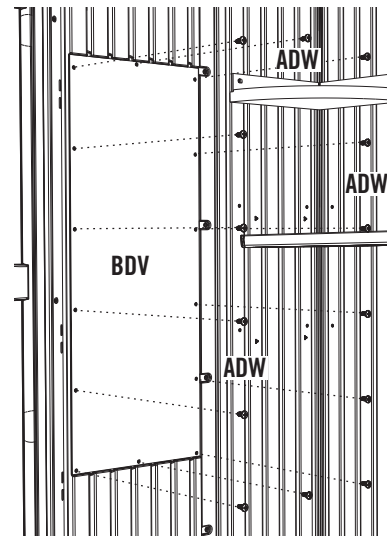
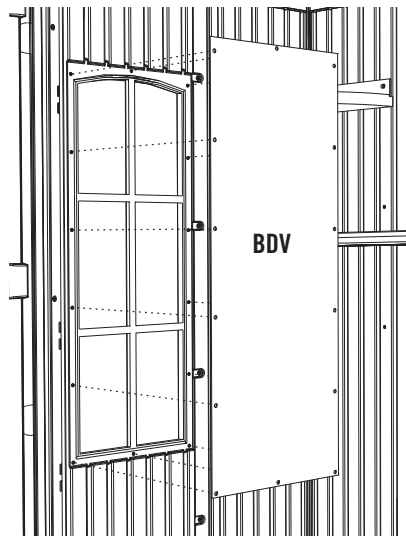

SEC

11.2

## WINDOW INSTALLATION

Remove the protective plastic film from **both sides** of the **Window (AHE)** and slide the Window into the grooves along the sides of the opening in the Window Wall Panel (Fig. 1). Insert the **#10-24 x 3/8" Pan-Head Screw (ADY)** into the hole at the bottom of the Window (Fig. 2) until flush. Attach a **Window Latch (AIS)** above each corner of the Window as shown. When tightening the **1/4" x 5/8" Pan-Head Screws (ADZ)**, ensure the Window Latches slide freely (Fig. 3). **Do not overtighten.**

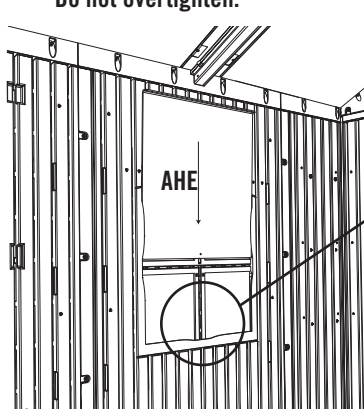

Fig. 1

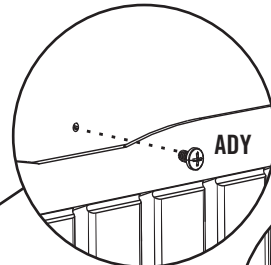

Fig. 2

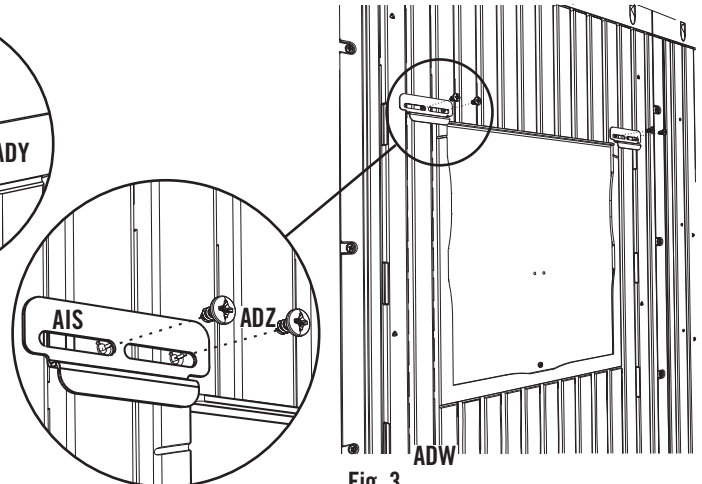
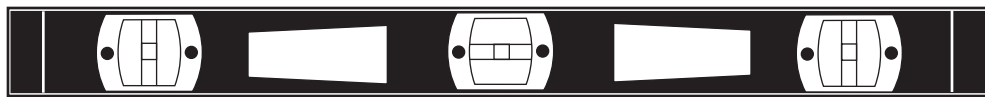

Fig. 3



*Note: Insert Window with bent edge at top and pointing away from the wall.*



12

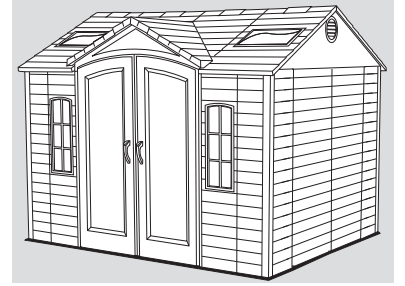
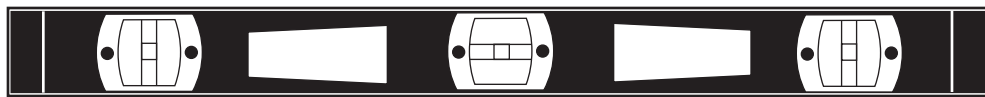

**SEC 13 FINAL STEPS**

***HARDWARE REQUIRED***

**NO HARDWARE REQUIRED FOR THIS SECTION**

***METAL PARTS REQUIRED***

**NO METAL PARTS PROVIDED FOR THIS SECTION**

***PLASTIC PARTS REQUIRED***

**NO PLASTIC PARTS REQUIRED FOR THIS SECTION**

***TOOLS REQUIRED***

***SMALL PARTS BOX REQUIRED: BUH***

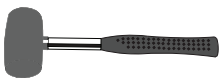

**Rubber Mallet**



**AIX (x4)  
Wood Shim (Included)**



**Safety Glasses**



## TOOLS AND HARDWARE REQUIRED FOR THIS PAGE

SEC 13



NO HARDWARE PROVIDED FOR THIS STEP

AIX (x4)

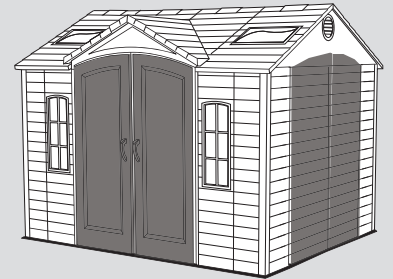

SEC

13.1

### DOOR ALIGNMENT

In some cases, the Doors may not completely line up at the top (fig. 1). When this happens, identify which side is higher and use a **Wood Shim (AIX)** to slightly raise the back corner of the high side until Doors line up (fig. 2). If Doors need further adjustment, insert another Shim under the front corner opposite of the first Shim. If the doors still need further adjustment, stack additional Shims (one at a time) alternating between the back and front Shims. After Doors are aligned, cut off any portion of wood Shim that is still exposed. From inside the Shed, drive a 1" nail through the floor into the Shim to hold it in place. **If you've anchored you shed, tighten all anchoring hardware now.**

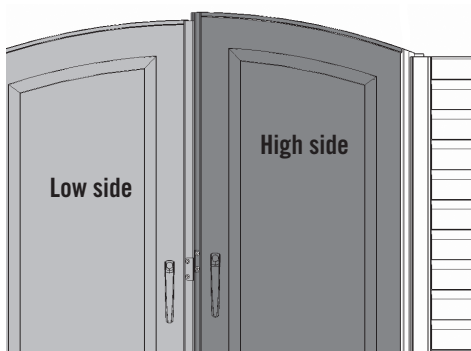

Fig. 1

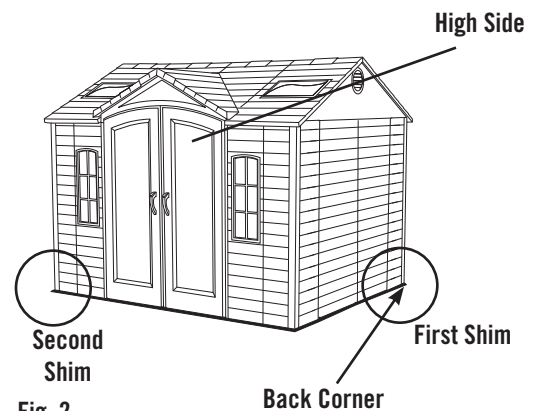

Fig. 2



*Note: Shim should be placed at the corner, running directly under one wall.*



## ***CLEANING & CARE***

Congratulations on your Lifetime® product purchase. By following the instructions below, your new Lifetime product should provide you with years of service and enjoyment.

### **Cleaning and Care**

The polyethylene panels are stain- and solvent-resistant. Most stains can be removed, using a mild soap and a soft-bristled brush. Abrasive cleaning materials may scratch the plastic and are not recommended. Repair scratches or rust spots on the metal by sanding the affected area lightly; using a rust preventative spray primer; and finally, spraying with a high-gloss spray enamel paint. Avoid placing a direct heat source on or near surfaces unless using a heat barrier.

## LIFETIME OUTDOOR SHED EQUIPMENT

### 10-YEAR LIMITED FACTORY WARRANTY

**THE MANUFACTURER RESERVES THE RIGHT TO MAKE SUBSTITUTIONS TO WARRANTY CLAIMS IF PARTS ARE UNAVAILABLE OR OBSOLETE.**

1. Lifetime outdoor sheds are warranted to the original purchaser to be free from defects in material or workmanship for a period of ten years from the date of original retail purchase. The word “defects” is defined as imperfections that impair the use of the product. Defects resulting from misuse, abuse or negligence will void this warranty. This warranty does not cover defects due to improper installation, alteration or accident. This warranty does not cover damage caused by vandalism, rusting, “acts of nature” or any other event beyond the control of the manufacturer.
2. This warranty is nontransferable and is expressly limited to the repair or replacement of defective product. If the product is defective within the terms of this warranty, Lifetime Products, Inc. will repair or replace defective parts at no cost to the purchaser. Shipping charges to and from the factory or distribution center are not covered and are the responsibility of the purchaser. Labor charges and related expenses for removal, installation or replacement of the shed or its components are not covered under this warranty.
3. This warranty does not cover scratching or scuffing of the product that may result from normal usage. In addition, defects resulting from intentional damage, negligence, unreasonable use or hanging from the truss will void this warranty.
4. Liability for incidental or consequential damages is excluded to the extent permitted by law. While every attempt is made to embody the highest degree of safety in all equipment, freedom from injury cannot be guaranteed. The user assumes all risk of injury resulting from the use of this product. All merchandise is sold on this condition, and no representative of the company may waive or change this policy.
5. This product is not intended for institutional or commercial use; Lifetime Products, Inc. does not assume any liability for such use. Institutional or commercial use will void the warranty.
6. This warranty is expressly in lieu of all other warranties, expressed or implied, including warranties of merchantability or fitness for use to extent permitted by Federal and state law. Neither Lifetime Products, Inc., nor any representative assumes any other liability in connection with this product. This warranty gives you specific legal rights, and you may also have other rights which vary from state to state.

#### **PLEASE INCLUDE YOUR DATED SALES RECEIPT AND PHOTOGRAPHS OF DAMAGED PARTS.**

REPORT PRODUCT DEFECTS IN WRITING TO:

Lifetime Products, Inc., PO Box 160010 Clearfield, UT 84016-0010  
or call 1-800-225-3865 M-F 7 a.m. to 5 p.m. MST.

#### **REGISTER YOUR PRODUCT FOR QUICKER CUSTOMER SERVICE.**

Visit [www.lifetime.com](http://www.lifetime.com) or call 1-800-225-3865 to register your product today.

#### **FOR INTERNATIONAL WARRANTY CLAIMS:**

All warranty claims must be accompanied by a sales receipt. Report all warranty claims in writing to your regional sales support representative. Please include your dated sales receipt and photographs of damaged parts.

To Identify the representative for your region — Please visit: [www.lifetime.com/international](http://www.lifetime.com/international)



[www.lifetime.com](http://www.lifetime.com)

**ENHANCE YOUR LIFETIME® PURCHASE BY ADDING ACCESSORIES OR OTHER GREAT PRODUCTS**

---

*To purchase accessories or other Lifetime Products, visit us at:*

***www.lifetime.com***

***Or call: 1-800-424-3865***

---

