



OUTDOOR STORAGE

MODEL N° 60001

***OWNER'S MANUAL***

**Copy**

Keep this Identification Number in case you must contact our Customer Service Department.

## **IMPORTANT! PLEASE READ BEFORE BEGINNING ASSEMBLY**

Dear Valued Customer,

We would like to congratulate you on your purchase of a Lifetime® Outdoor Storage Shed! We are confident that you have made the perfect choice and you will be very pleased with your new storage solution.

Lifetime® Outdoor Storage is part of the family of products created and manufactured by Lifetime® Products, Inc. Like all of our products, you can be assured that the quality of your Lifetime Outdoor Storage Shed is the best in the world! And, we back that quality up by offering the best warranty in the business – A 10-year warranty that fully covers the Shed!

All of our Sheds are built with the highest-quality steel and high-density polyethylene (HDPE) parts. The design and construction of our steel-reinforced double-Wall Panels is second to none. All of our exposed steel parts and gables are powder coated and we use high-density polyethylene plastic. What makes polyethylene so special? It has superior strength and durability, and, it won't crack or degrade outdoors.

So now that you know the quality you are getting in a Lifetime Outdoor Storage Shed, please take the time to READ THIS INSTRUCTION MANUAL!

We have taken great care in providing the best possible form of instructions to help you put your new Outdoor Storage Shed together. Before you get started, PLEASE read the following preparation tips to help you get started!

We can assure you, your construction experience will be a lot more enjoyable if you do!

### PREPARATION TIPS:

- The first step is simple... RELAX! You have made a great purchase, but Rome was not built in a day. Plan to spend a good part of your weekend putting together your fine Outdoor Storage Shed. Our philosophy is, if it comes together quickly and easily, it surely will come apart quickly and easily! Your Lifetime® Outdoor Storage Shed will surely last a long, long time, if you are patient, and take all the time necessary to put it together as we have instructed.
- Grab a friend to join in on the fun! This is not a one-person endeavor. We have found that not only will things go smoother if you have two or more people participating in the construction of the Shed, but it will go quicker as well. So, the more the merrier!
- Make sure you have all the tools necessary for constructing your new Shed. There is a "Tools Required For This Assembly" list on page five of this Owner's Manual.
- The plastic pieces of your Shed may become damaged by over tightening the screws. To avoid this damage, we strongly recommend the use of a low-powered power screwdriver or a drill that has an adjustable clutch that is set on a low-torque setting. If neither is available, use a hand screwdriver. If a hand screwdriver is all you have, take several breaks... your wrist will need it!
- You will also need two small ladders (when it comes time to do the roof!).

## **IMPORTANT! PLEASE READ BEFORE BEGINNING ASSEMBLY**

- Before beginning assembly, remove the Parts List from the center of this Owner's Manual and take an inventory of the parts included with your Outdoor Storage Shed. Also, read through the entire instruction manual. It's always a great practice to get a feel for the flow of the process and to familiarize yourself with the parts involved. But, try not to get ahead of yourself and start the process out of order.
- FOLLOW THE INSTRUCTIONS IN ORDER! Everything goes together in a certain order, and we have learned what that correct order should be. In our state-of-the-art research and testing facility, we have painstakingly created these instructions. The order of construction is there for a reason, and some parts simply will not fit if built out of order. Just follow along with the order in the instructions and everything will fit together and things will go very smooth.
- YOUR SHED MUST BE BUILT ON A LEVEL SURFACE! If the spot you have chosen to place your wonderful new Outdoor Storage Shed is not level, the Shed will not assemble correctly! We recommend a concrete patio, a wood platform or creating a pad with pea gravel. Your Shed is meant to last a lifetime, so provide the proper foundation for it before you start to build.
- Before you build it, make sure you are allowed to build it! Consult all building codes, as well as city and county ordinances, to ensure that you do not require a building permit to construct your Outdoor Storage Shed. Proper building permit documentation may be required in your neighborhood, and it would be quite unfortunate to learn this after your Outdoor Storage Shed is already built!

Now that you're ready to begin the construction of your wonderful new Outdoor Storage Shed, step back, take a deep breath, get yourself a large cold beverage and enjoy yourself. We guarantee that after spending the right amount of time in building your Shed, you will be able to enjoy it for years to come.

Thanks for choosing Lifetime®, and have fun!

## **ABOUT LIFETIME PRODUCTS, INC.**

Lifetime Products, Inc., has applied innovation and cutting-edge technology in plastics and metals to create a family of affordable lifestyle products that feature superior strength and durability. The world's leading manufacturer of folding tables and chairs, Lifetime was founded in 1986 as the maker of portable basketball systems that revolutionized the industry with patented technology. With diverse offerings such as outdoor storage sheds and steel utility trailers, Lifetime continues to develop innovative products that outfit the way you live.

Lifetime makes the things you need for the lifestyle you want. By innovating products in and around the home, Lifetime simplifies your everyday life and enables you to get the most out of your free time.



## REGISTER YOUR LIFETIME PRODUCT TODAY!

There are benefits to registering your Lifetime product. With our new online product registration form, it's fast and easy! Register with us at [www.lifetime.com](http://www.lifetime.com) and enjoy these great benefits:

- Receive exclusive money-saving offers from BuyLifetime.com, our online store, as well as NEW product notifications and special closeout promotions!
- In the unlikely event of a product recall or safety modification, we will notify you.
- Registering your product guarantees you warranty service. If you do not register your product, your warranty rights will not be diminished. But you will need to provide a sales receipt to verify your product purchase date before warranty service will be provided.

### LIFETIME'S PROMISE TO YOU:

*Maintaining your privacy is our long-standing policy at Lifetime. And you can rest assured that Lifetime will not sell or provide your personal data to other third parties, or allow them to use your personal data for their own purposes.*

We invite you to read our privacy policy at [www.lifetime.com](http://www.lifetime.com)

**REGISTER today!**

**\*\*U.S. and Canada customers ONLY\*\***

IF ASSISTANCE IS NEEDED,

**DO NOT CONTACT THE STORE!**

**CALL OUR CUSTOMER SERVICE DEPARTMENT at 1 (800) 225-3865**

HOURS: 7:00 a.m. to 5:00 p.m. Monday through Friday (Mountain Standard Time)

\*\*Call, or visit our Web site for Saturday hours\*\*

\*\*For customers outside the U.S. or Canada, please contact the store for assistance.\*\*



## SAFETY INSTRUCTIONS



### FAILURE TO FOLLOW THESE WARNINGS MAY RESULT IN SERIOUS INJURY OR PROPERTY DAMAGE AND WILL VOID WARRANTY.

To ensure safety, do not attempt to assemble this product without following the instructions carefully. Check entire box and inside all packing material for parts and/or additional instruction material. Before beginning assembly, read the instructions and identify parts using the hardware identifier and parts list in this document. Proper and complete assembly, use and supervision are essential to reduce the risk of accident or injury.

- Do not use or store hot objects such as grills, blowtorches, welding equipment, etc. near the product.
- If using a ladder during assembly, use extreme caution.
- Two capable adults are required for assembly. (It is also recommended that a third adult function as an instruction reader.)

*Most injuries are caused by misuse and/or not following instructions. Use caution when using this product.*

## BEFORE BEGINNING ASSEMBLY



Keep the hardware bags and their contents separate. If any parts are missing, call our Customer Service Department.



Read the “Congratulations” letter on page 2-3. Identify and inventory all parts and hardware using the parts and hardware lists and identifiers in this document.

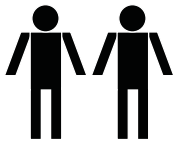













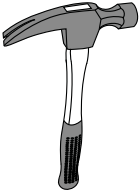



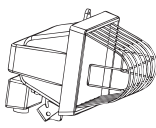

***\*Two adults required to complete assembly\****

**Only adults should set up the product. Do not allow children in the set-up area until assembly is complete.**

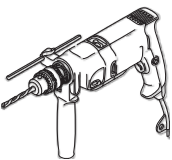

## TOOLS REQUIRED FOR THIS ASSEMBLY

7/16"	3/8"	Adjustable Wrench	Rubber Mallet	Hammer	Box Knife	Phillips Screwdriver	Plain Screwdriver	3/8" Masonry Drill Bit	2" x 4" x 8' Leveling Board
									
(2)	(1)	(1)	(1)	(1)	(1)	(1)	(1)	(1)	(1)
Ladder	Electric Drill	Work Light	Pliers	Flashlight	Hammer Drill	Safety Glasses			
									
(2)	(1)	(1)	(1)	(1)	(1)	(1 pair for each person)		(1)	(1)

\*Read the “Screwdriver Notice” on page 7.

## ASSEMBLY GUIDES

*Refer to the following areas throughout the instructions to assist in the assembly process:*

This area is located at the top, left-hand corner of the page and indicates which tools and hardware are needed to complete the assembly steps on a page.



TOOLS AND HARDWARE REQUIRED FOR THIS PAGE

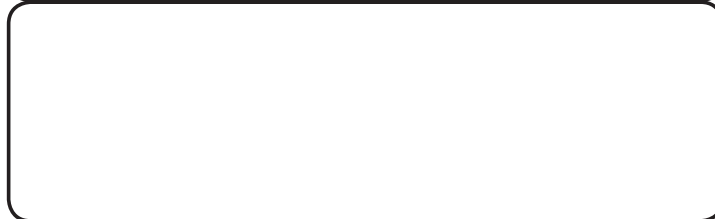

This area is located at the top, right-hand corner of the page and shows an image of the product with shaded parts indicating which section is being assembled.



This area is usually located in the bottom, left-hand corner of a step and indicates that special attention is needed to perform a particular part of a step.



Note:

These areas are usually located in the bottom, right-hand corner of a step and indicate that damage to the product or serious injury may occur if the caution or warning is not heeded.



CAUTION



WARNING

Throughout the Parts & Hardware List, Part & Hardware Identifiers, and instructions are three-letter IDs. These IDs are below the images of the parts and hardware to help you locate and identify the parts and hardware during assembly. These IDs are not necessarily on the parts themselves.

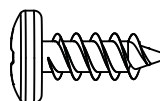

ADZ (x10)  
1/4" x 5/8" Pan-Head Screw

## IMPORTANT NOTICES

### Level Surface Notice:

Surface must be leveled before installation. We recommend building a level work space with a concrete or patio style surface. If the surface is not properly leveled, the Outdoor Shed will not assemble correctly. Proper surface leveling will save you time in the long run, so please do not ignore this step.

---

### Building Code Notice:

Consult all local building codes, as well as city and county ordinances, to ensure that the construction of the Outdoor Shed does not require a building permit. Proper building permit documentation may be required in your neighborhood, and it would be unfortunate to learn this after constructing the Shed.

---

### Screwdriver Notice:

You may use a #2 Phillips head screwdriver bit and a power screwdriver or drill, instead of a hand screwdriver. However, be aware that the plastic pieces of your Shed can be damaged by overtightening of screws. To avoid damage we strongly recommend the use of a low-powered power screwdriver or a drill that has an adjustable clutch that is set on a low torque setting. If neither is available, use a hand screwdriver. In any case use caution to avoid overtightening the screws.

---

### Floor Puncture Notice:

Sharp objects may damage your floor. If resting sharp, heavy objects on your Shed floor, place a block of wood between the sharp object and floor.



### CAUTION:

If more than six (6) inches of snow accumulate on the roof of the shed, carefully remove the snow to avoid possible roof collapse. While standing on the ground, remove the snow from the roof with a broom or snow shovel. Do not stand on the roof to remove snow.

## PARTS & HARDWARE LIST

### BOX 1

ID	Description	Qty
AGR	Outer Floor Panel	2
AFX	Center Floor Panel	2
AGH	Side Gable 1	1
AGI	Side Gable 2	1
AGQ	Roof Panel	4
AHB	Roof Panel for Domed Skylight	2
AFY	Center Roof Cap	3
AGO	Left Side Door (No Notch)	1
AGZ	Right Side Door (No Notch)	1
BDS	Lower Right, Front Gable Roof Panel	1
BDR	Lower Left, Front Gable Roof Panel	1
BDU	Upper Right, Front Gable Roof Panel	1
BDT	Upper Left, Front Gable Roof Panel	1
BDW	Front Entry Gable Roof Cap	1
BDC	Front Entry Gable	1
AGF	Side Entry Gable	1
AFV	90" Shelf	1
<b>CRF</b>	<b>METAL PARTS KIT 1</b>	
AFH	Truss Gutter Channel	3
AFC	Door End Channel	2
BDD	Front Entry Header Bar	1
CRE	Short Door Hinge Tube	2
<b>CRG</b>	<b>METAL PARTS KIT 2</b>	
AFC	Door End Channel	2
AFG	Roof Truss Brace	3
AFM	Wall/Shelf Support Channel	4
BFJ	Side Entry Header Bar	1
CRD	Long Door Hinge Tube	2
<b>CKQ</b>	<b>METAL PARTS KIT 3</b>	
BDQ	Center Angled Truss Channel	1
BDP	Right Angled Truss Channel	1
BDO	Left Angled Truss Channel	1

### BOX 2

BDJ	Left Front Door (Notched)	1
BDK	Right Front Door (Notched)	1
AGY	Corner Wall Panel 104	1
AGN	Corner Wall Panel 105	1
AGW	Corner Wall Panel 106	1
AGL	Corner Wall Panel 107	1
AHD	Wall Panel	4
AHH	Window Wall Panel	1
BDI	Right Half-Window Wall Panel	1
BDH	Left Half-Window Wall Panel	1
<b>CGU</b>	<b>SMALL PARTS KIT</b>	
AHC	Skylight	4
AGG	Left End Roof Cap	1
AFW	Right End Roof Cap	1
AFZ	Corner Shelf	4
AFL	Roof Support	8
AHE	Window	1
AQX	Truss Connector	3
BDV	Half-Wall Window	2
AGB	Domed Skylight	2
<b>BOD</b>	<b>SMALL PARTS BOX</b>	
AIX	Wood Shim	4
AIW	Wood Block	1
AFU	Pegboard Strip	2
<b>CRC</b>	<b>FLOOR ASSEMBLY HARDWARE</b>	
BQC	#8 x 1/2" Pan-Head Screw	20
AHO	Door Hinge Bushing	4
ADC	#2 Phillips Bit	1

ID	Description	Qty
<b>BEA</b>	<b>TRUSS ASSEMBLY HARDWARE</b>	
ADJ	1/4" Cap Nut	18
ADY	#10 x 3/8" Pan-Head Screw	12
ADK	#10 Cap Nut	12
AQY	1/4" x 2" Phillips Truss Screw	12
ADH	1/4" Threaded Rod	3
<b>BEB</b>	<b>WALL PANEL INSTALLATION HARDWARE</b>	
ADZ	1/4" x 5/8" Pan-Head Screw	85
<b>BEC</b>	<b>DOMED SKYLIGHT ASSEMBLY PARTS (x2)</b>	
ACR	#10 x 5/8" Carriage Bolt	12
AEE	#10 x 1/2" Flat Washer	12
ADK	#10 Cap Nut	12
AHI	6' 1/4" x 3/4" Butyl Tape	1
<b>GABLE ASSEMBLY HARDWARE</b>		
<b>BEE</b>	<b>Front Entry Gable Assembly Hardware</b>	
ADV	1/4" x 1 1/8" Pan Head Screw	4
AHS	End Plug	2
<b>BHV</b>	<b>Side Entry Gable Assembly Hardware (x2)</b>	
AGP	Louvered Vent	1
AIQ	Vent Screen	1
ADW	#10 x 3/4" Pan-Head Screw	5
AEE	#10 x 1/2" Flat Washer	5
AHS	End Plug	2
ADV	1/4" x 1 1/8" Pan-Head Screw	6
ADZ	1/4" x 5/8" Pan-Head Screw	4
ACB	#10 x 1 1/4" Pan-Head Screw (Not used)	1
<b>BEF</b>	<b>LEFT DOOR ASSEMBLY HARDWARE (x2)</b>	
AHZ	Left Door Handle	1
AHM	Deadbolt Latch	2
ACH	1/4" x 1 1/2" Carriage Bolt	2
ADW	#10 x 3/4" Pan-Head Screw	3
AEE	#10 x 1/2" Flat Washer	3
ADJ	1/4" Cap Nut	2
AIA	Left Door Lock Bracket	1
AIB	Left Door Strike Plate	1
<b>BEG</b>	<b>RIGHT DOOR ASSEMBLY HARDWARE (x2)</b>	
AIK	Right Door Handle	1
ACI	1/4" x 2" Carriage Bolt	2
ADB	3/8" x 1/2" Steel Spacer	2
AAB	1/4" Centerlock Nut	2
AHY	Latch Spring	1
AHW	Thumb Lever Extension	1
AIO	Thumb Lever	1
ADW	#10 x 3/4" Pan-Head Screw	4
AHX	Latch Cover Plate	1
AHV	Door Latch	1
AIL	Right Door Lock Bracket	1
AEB	1/4" Flat Washer	2
AEE	#10 x 1/2" Flat Washer	5
<b>BOE</b>	<b>GABLE, TRUSS, DOOR &amp; ROOF INSTALLATION HARDWARE</b>	
ADZ	1/4" x 5/8" Pan-Head Screw	160
AED	#10 x 1" Fender Washer	24
AQZ	Entry Gable Bracket	2
ADX	#10 x 1/2" Pan-Head Screw	32
ARA	1/8" Drill Bit	1
AXX	Truss Hole Insert	2
AHP	Cotter Pin	4
AQY	1/4" x 2" Phillips Truss Screw	4
ADJ	1/4" Cap Nut	4
AIM	Right Gap Flap	1
AIC	Left Gap Flap	1
AJA	1/2" Foam Cube	2



## PARTS & HARDWARE LIST

### BOX 2 (CONT.)

ID	Description	Qty	ID	Description	Qty
<b>BEI WINDOW INSTALLATION HARDWARE</b>			<b>BHC PEGBOARD STRIP HARDWARE</b>		
ADW	#10 x 3/4" Pan Head Screw	28	ADW	#10 x 3/4" Pan-Head Screws	10
ADZ	1/4" x 5/8" Pan-Head Screw	4	<b>BHD TOOL CLIP ASSORTMENT</b>		
AIS	Window Latch Bracket	2	AIF	2" Double-Arm Hook	1
ADY	#10 x 3/8" Pan-Head Screw	1	AIG	4" Double-Arm Hook	1
<b>SHELF INSTALLATION HARDWARE</b>			AIH	J-Hook	3
<b>BHH 90" SHELF HARDWARE</b>			AII	L-Hook	3
ADZ	1/4" x 5/8" Pan-Head Screws	14	AIJ	Toolholder	2
AIY	10" Shelf Bracket	2			
<b>BHI CORNER SHELF HARDWARE (x4)</b>					
ADZ	1/4" x 5/8" Pan-Head Screws	4			

## PARTS IDENTIFIER

### BOX 1

#### SHED PARTS BOX

Parts shown at 4% of actual size

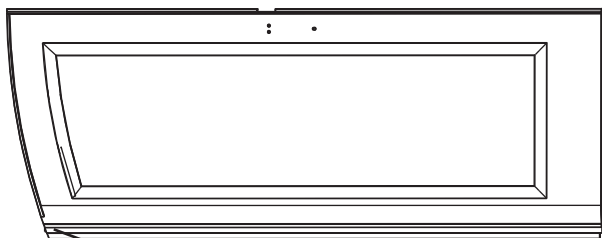

**AGO (x1)**  
Left Side Door (No Notch)

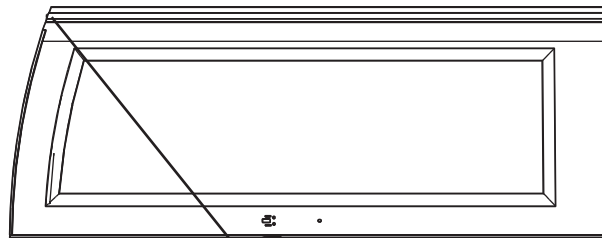

**AGZ (x1)**  
Right Side Door (No Notch)

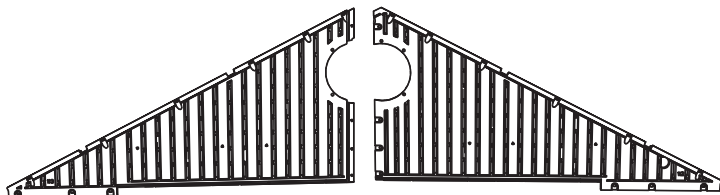

**AGH (x1)**  
Side Gable 1

Rear View

**AGI (x1)**  
Side Gable 2

Rear View

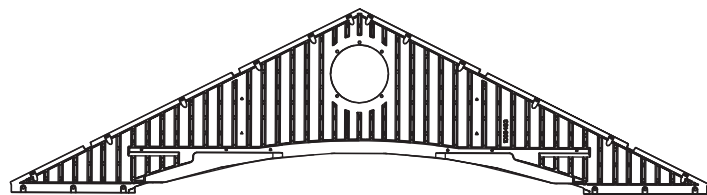

**AGF (x1)**  
Side Entry Gable

Rear View

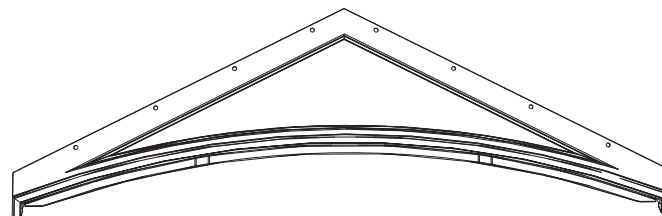

**BDC (x1)**  
Front Entry Gable

Front View

**!** *Note: Throughout the Parts & Hardware List, Part & Hardware Identifiers, and instructions are three-letter IDs. These IDs are below the images of the parts and hardware to help you locate and identify the parts and hardware during assembly. These IDs are not necessarily on the parts themselves.*

# PARTS IDENTIFIER

## BOX 1

Parts shown at 4% of actual size

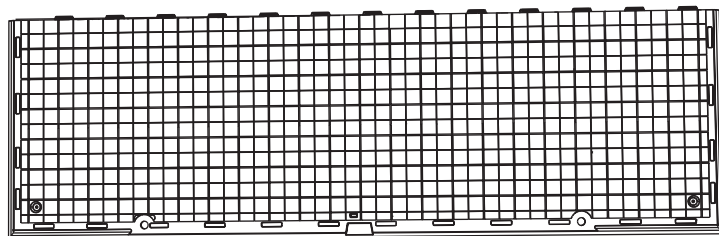

**AGR (x2)**  
Outer Floor Panel

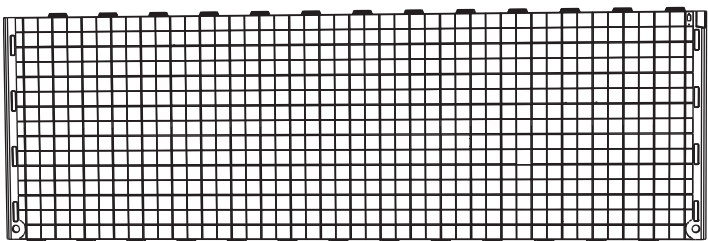

**AFX (x2)**  
Center Floor Panel

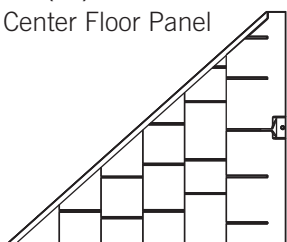

**BDT (x1)**  
Upper Left, Front Gable Roof Panel

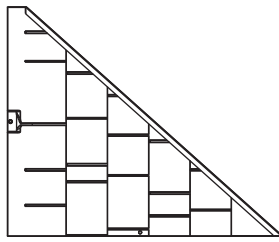

**BDU (x1)**  
Upper Right, Front Gable Roof Panel

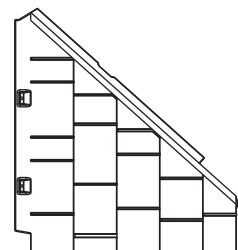

**BDS (x1)**  
Lower Right, Front Gable Roof Panel



**AFV (x1)**  
90" Shelf

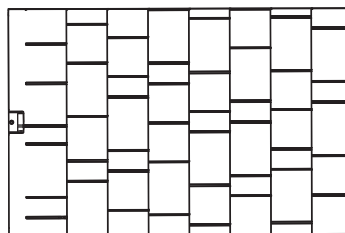

**AGQ (x4)**  
Roof Panel

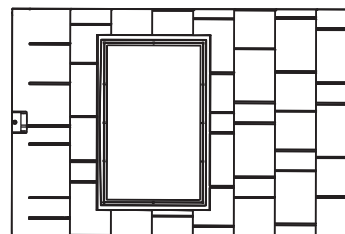

**AHB (x2)**  
Roof Panel for Domed Skylight

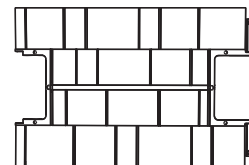

**AFY (x3)**  
Center Roof Cap

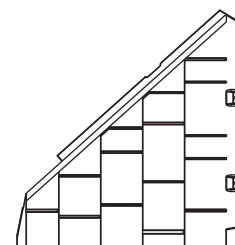

**BDR (x1)**  
Lower Left, Front Gable Roof Panel

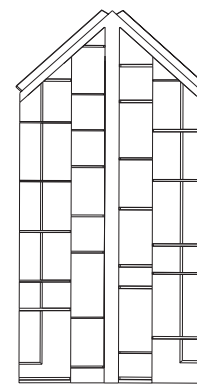

**BDW (x1)**  
Front Entry Gable Roof Cap

## [CRF] METAL PARTS KIT 1

Parts shown at 8% of actual size

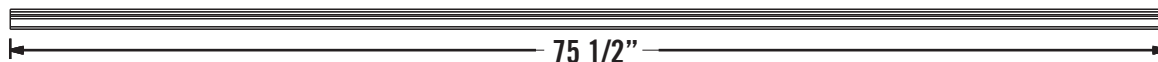

**AFC (x2)**  
Door End Channel

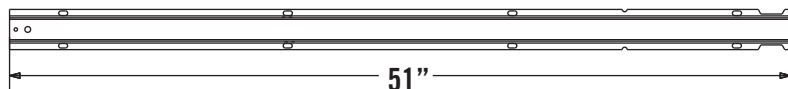

**AFH (x3)**  
Truss Gutter Channel



**BDD (x1)**  
Front Entry Header Bar



**CRE (x2)**  
Short Door Hinge Tube (For Door with Notch)

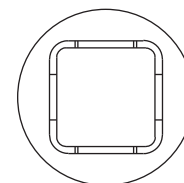
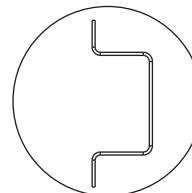
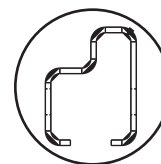

# PARTS IDENTIFIER

## BOX 1

### [CRG] METAL PARTS KIT 2

Parts shown at 8% of actual size

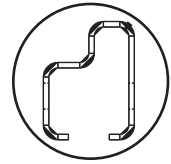
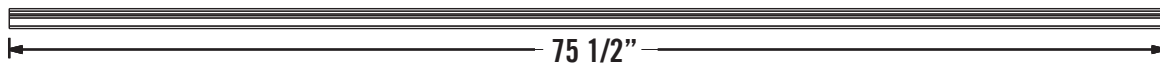

**AFC** (x2)  
Door End Channel

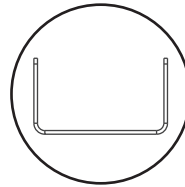

**AFG** (x3)  
Roof Truss Brace

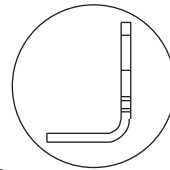
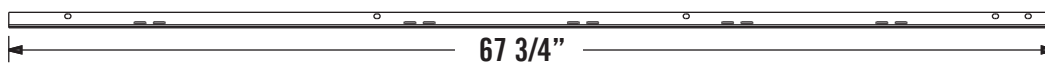

**AFM** (x4)  
Wall/Shelf Support Channel

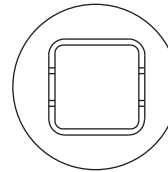

**BFJ** (x1)  
Side Entry Header Bar



**CRD** (x2)  
Long Door Hinge Tube (For Door with No Notch)

### [CKQ] METAL PARTS KIT 3

Parts shown at 8% of actual size

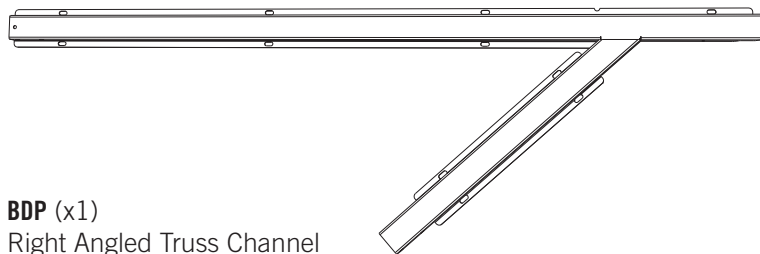

**BDP** (x1)  
Right Angled Truss Channel

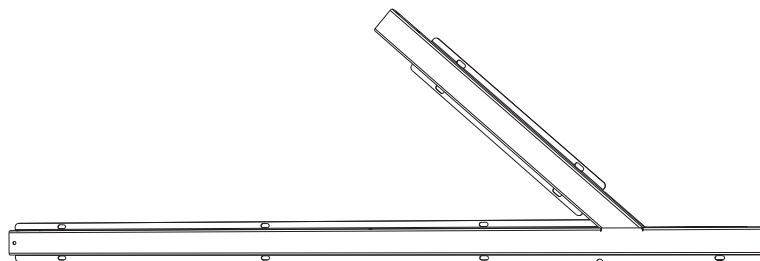

**BDO** (x1)  
Left Angled Truss Channel

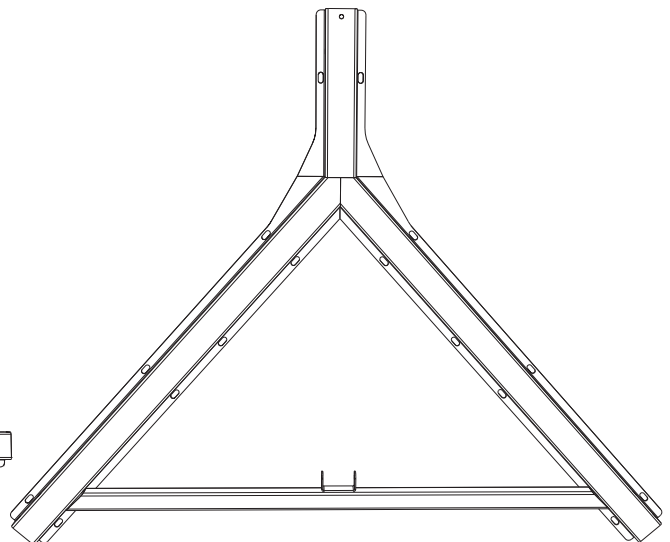

**BDQ** (x1)  
Center Angled Truss Channel

# PARTS IDENTIFIER

## BOX 2

### SHED PARTS BOX

Parts are shown 4% of actual size

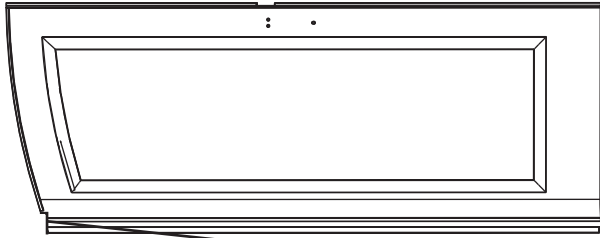

**BDJ** (x1) Left Front Door (Notched)

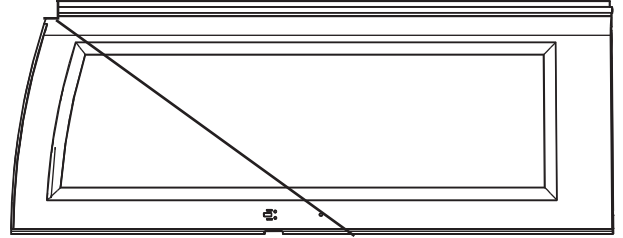

**BDK** (x1) Right Front Door (Notched)

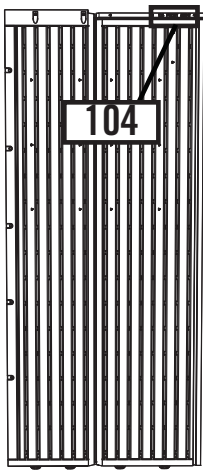

**AGY** (x1)  
Corner Wall Panel 104

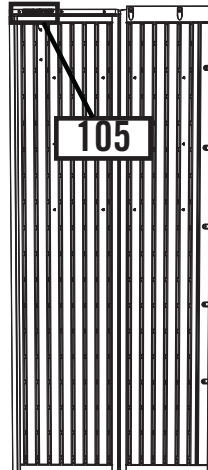

**AGN** (x1)  
Corner Wall Panel 105

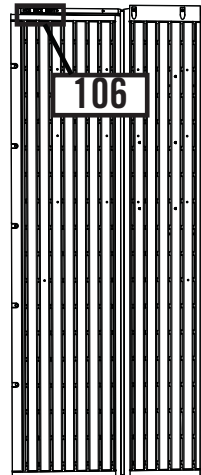

**AGW** (x1)  
Corner Wall Panel 106

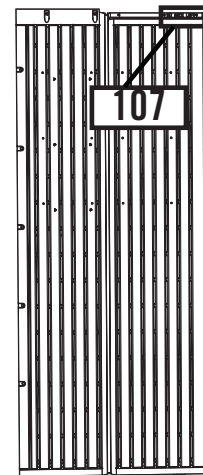

**AGL** (x1)  
Corner Wall Panel 107

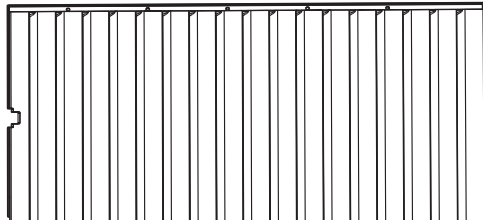

**AHD** (x4)  
Wall Panel



**AHH** (x1)  
Window Wall Panel

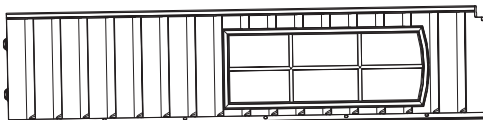

**BDI** (x1)  
Right Half-Window Wall Panel

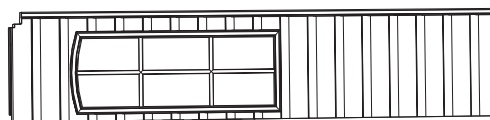

**BDH** (x1)  
Left Half-Window Wall Panel

### [CGU] SMALL PARTS KIT

Parts are shown 8% of actual size

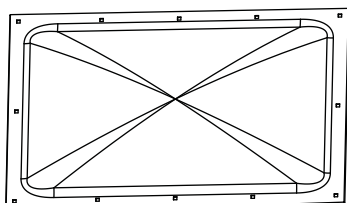

**AGB** (x2)  
Domed Skylight



**AFL** (x8)  
Roof Support

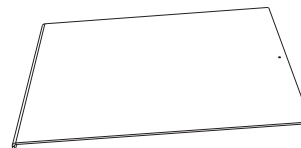

**AHE** (x1)  
Window

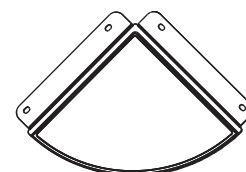

**AFZ** (x4)  
Corner Shelf

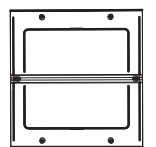

**AHC** (x4)  
Skylight

## PARTS IDENTIFIER

### BOX 2

#### [CGU] SMALL PARTS KIT (CONT.)

Parts are shown 4% of actual size

**115**

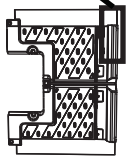

**AGG (x1)**  
Left End Roof Cap

**116**

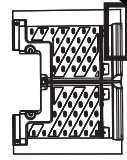

**AFW (x1)**  
Right End Roof Cap

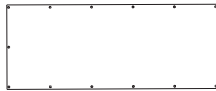

**BDV (x2)**  
Half-Wall Window

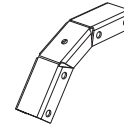

**AQX (x3)**  
Truss Connector  
(Not to scale)

#### [BOD] SMALL PARTS BOX

Parts are not shown to scale



**AIW (x1)**  
Wood Block

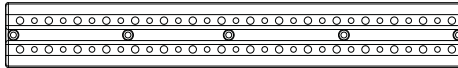

**AFU (x2)**  
Pegboard Strip



**AIX (x4)**  
Wood Shim

## HARDWARE IDENTIFIER

#### [CRC] FLOOR ASSEMBLY HARDWARE

Hardware shown at actual size

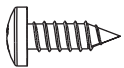

**BQC (x20)**  
#8 x 1/2" Pan-Head Screw (Only 12 used)



**ADC (x1)**  
#2 Phillips Bit

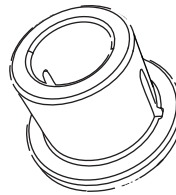

**AHO (x4)**  
Door Hinge Bushing

#### [BEC] DOMED SKYLIGHT ASSEMBLY HARDWARE (x2)

Hardware shown at actual size (\*unless otherwise noted)

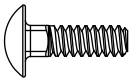

**ACR (x12)**  
#10 x 5/8" Carriage Bolt

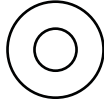

**AEE (x12)**  
#10 x 1/2" Flat Washer



**ADK (x12)**  
#10 Cap Nut



**\*AHI (x1)**  
Butyl Tape

#### [BEA] TRUSS FRAME ASSEMBLY HARDWARE

Hardware shown at actual size (\*unless otherwise noted)



**ADJ (x18)**  
1/4" Cap Nut



**ADK (x12)**  
#10 Cap Nut

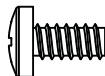

**ADY (x12)**  
#10 Flat-Head Screw

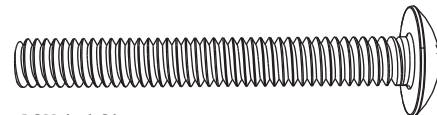

**AQY (x12)**  
1/4" x 2" Phillips Truss Screw

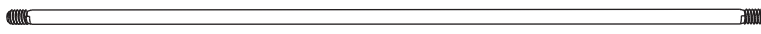

**\*ADH (x3)** 1/4" Threaded Rod

# HARDWARE IDENTIFIER

## BOX 2

### [BHV] SIDE ENTRY GABLE ASSEMBLY HARDWARE (x2)

Hardware shown at actual size (\*unless otherwise noted)

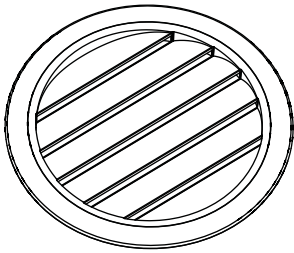

**\*AGP (x1)**  
Louvered Vent

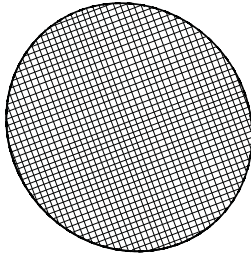

**\*AIQ (x1)**  
Vent Screen

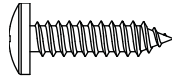

**ADW (x5)**  
#10 x 3/4" Pan-Head Screw

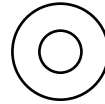

**AEE (x5)**  
#10 x 1/2" Flat Washer

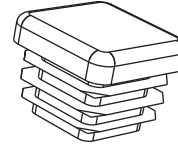

**AHS (x2)**  
End Plug  
(Only 2 used)

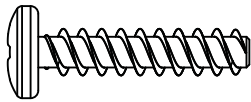

**ADV (x6)**  
1/4" x 1 1/8" Pan-Head Screw  
(Only 6 used)

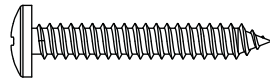

**ACB (x1)**  
#10 x 1 1/4" Pan-Head Screw  
(Not used)

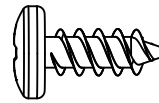

**ADZ (x4)**  
1/4" x 5/8" Pan-Head Screw  
(Only 4 used)

### [BEB] WALL PANEL INSTALLATION HARDWARE

Hardware shown at actual size

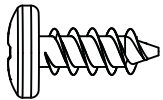

**ADZ (x85)**  
1/4" x 5/8" Pan-Head Screw

### [BEE] FRONT ENTRY GABLE ASSEMBLY HARDWARE

Hardware shown at actual size (\*unless otherwise noted)

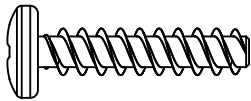

**ADV (x4)**  
1/4" x 1 1/8" Pan-Head Screw

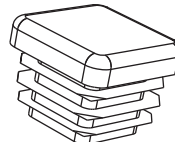

**AHS (x2)**  
End Plug

### [BEF] LEFT DOOR ASSEMBLY HARDWARE (x2)

Hardware shown at actual size (\*unless otherwise noted)

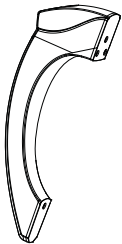

**\*AHZ (x1)**  
Left Door Handle



**\*AHM (x2)**  
Deadbolt Latch

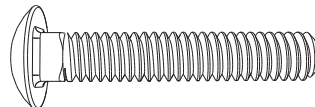

**ACH (x2)**  
1/4" x 1 1/2" Carriage Bolt

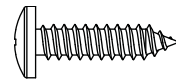

**ADW (x3)**  
#10 x 3/4" Pan-Head Screw

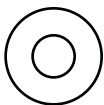

**AEE (x3)**  
#10 x 1/2" Flat Washer



**ADJ (x2)**  
1/4" Cap Nut

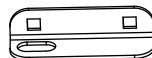

**\*AIA (x1)**  
Left Door Lock Bracket

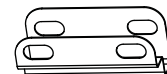

**\*AIB (x1)**  
Left Door Strike Plate

# HARDWARE IDENTIFIER

## BOX 2

### [BEG] RIGHT DOOR ASSEMBLY HARDWARE (x2)

Hardware shown at actual size (\*unless otherwise noted)

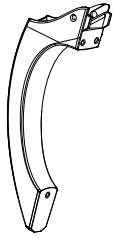

**\*AIK** (x1)  
Right Door Handle

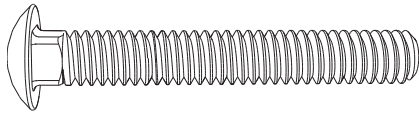

**ACI** (x2)  
1/4" x 2" Carriage Bolt

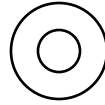

**AEE** (x5)  
#10 x 1/2" Flat Washer

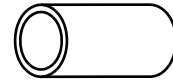

**ADB** (x2)  
3/8" x 1/2" Steel Spacer

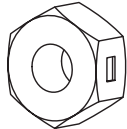

**AAB** (x2)  
1/4" Centerlock Nut

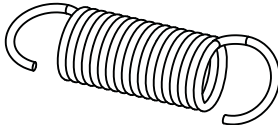

**AHY** (x1)  
Latch Spring

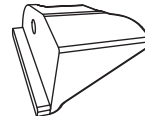

**\*AHW** (x1)  
Thumb Lever Extension

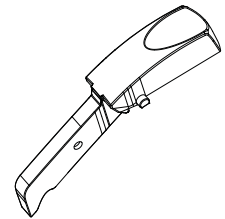

**\*AIO** (x1)  
Thumb Lever

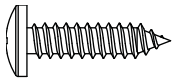

**ADW** (x4)  
#10 x 3/4" Pan-Head Screw

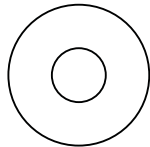

**AEB** (x2)  
1/4" Flat Washer



**\*AHX** (x1)  
Latch Cover Plate

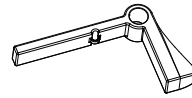

**\*AHV** (x1)  
Door Latch

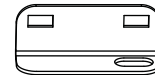

**\*AIL** (x1)  
Right Door Lock Bracket

### [BOE] GABLE, TRUSS, DOOR, & ROOF INSTALLATION HARDWARE

Hardware shown at actual size (\*unless otherwise noted)

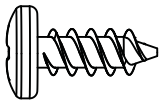

**ADZ** (x160)  
1/4" x 5/8" Pan-Head Screw  
(Not all screws will be used)

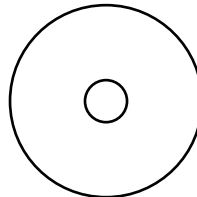

**AED** (x24)  
#10 x 1" Fender Washer

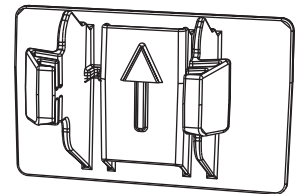

**\*AXX** (x2)  
Truss Hole Insert

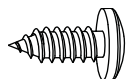

**ADX** (x32)  
#10 x 1/2" Pan-Head Screw



**AHP** (x4)  
Cotter Pin



**ARA** (x1)  
1/8" Drill Bit

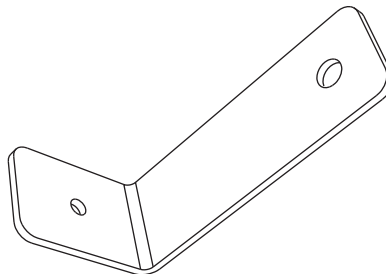

**\*AQZ** (x2)  
Entry Gable Bracket

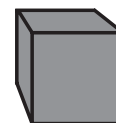

**AJA** (x2)  
Foam Cube

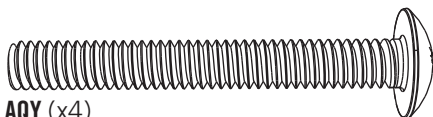

**AQY** (x4)  
1/4" x 2" Phillips Truss Screw

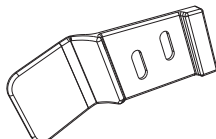

**\*AIM** (x1)  
Right Gap Flap

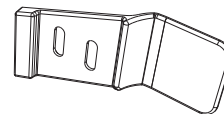

**\*AIC** (x1)  
Left Gap Flap



**ADJ** (x4)  
1/4" Cap Nut

# HARDWARE IDENTIFIER

## BOX 2

### WINDOW INSTALLATION HARDWARE

Hardware shown at actual size (\*unless otherwise noted)

#### [BEI] Half-Window Installation Hardware [1047659] (x2)

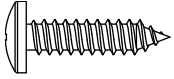

**ADW** (x14)  
#10 x 3/4" Pan-Head Screw

#### [BEI] Window Installation Hardware

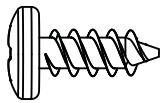

**ADZ** (x4)  
1/4" x 5/8" Pan-Head Screw

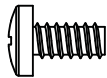

**ADY** (x1)  
#10 x 3/8" Pan-Head Screw

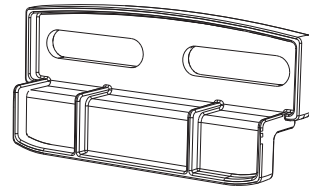

**AIS** (x2)  
Window Latch Bracket

### SHELF INSTALLATION HARDWARE

Hardware shown at actual size (\*unless otherwise noted)

#### [BHH] 90" Shelf Installation Hardware

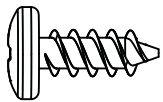

**ADZ** (x14)  
1/4" x 5/8" Pan-Head Screw



**\*AIY** (x2)  
10" Shelf Bracket

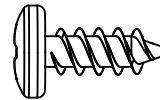

**ADZ** (x4)  
1/4" x 5/8" Pan-Head Screw

#### [BHI] Corner Shelf Installation Hardware (x4)

### [BHC] PEGBOARD STRIP INSTALLATION HARDWARE

Hardware shown at actual size

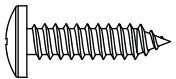

**ADW** (x10)  
N° 10" x 3/4" Pan-Head Screw  
(Not all screws are used)

#### [BHD] Tool Clip Assortment

Hardware shown at 50% of actual size

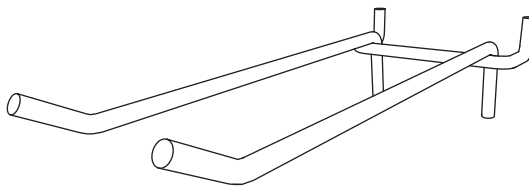

**AIG** (x1)  
4" Double-Arm Hook

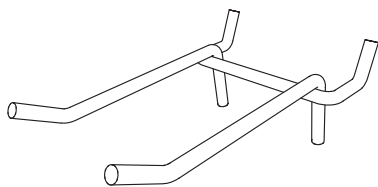

**AIF** (x1)  
2" Double-Arm Hook



**AIH** (x3)  
J-Hook

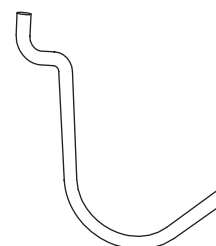

**AII** (x3)  
L-Hook

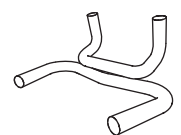

**AIJ** (x2)  
Toolholder





## TOOLS AND HARDWARE REQUIRED FOR THIS PAGE

SEC 1



Concrete (1 cu. yd.)

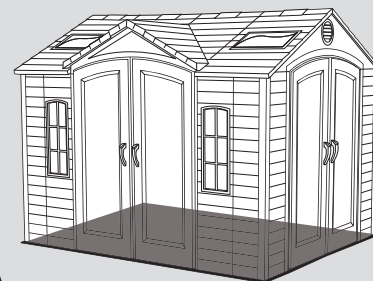

SEC

1.1

### SITE PREPARATION - CONCRETE PLATFORM PREPARATION

The actual dimensions of your shed (at its widest and longest points) are 8' x 10'. Ensure you select a site that will accommodate these measurements. The base of the shed is slightly smaller than this, so you will need to create a level surface that is at least 93 1/2" x 118 1/4". We recommend using a level cement or patio style surface. This will provide the best long-term performance for your shed.

**!** *Note: Shed Extension Kits are available for this shed. Please consider possible shed expansion when planning the site for your shed. See back cover of this manual for information on ordering accessories.*

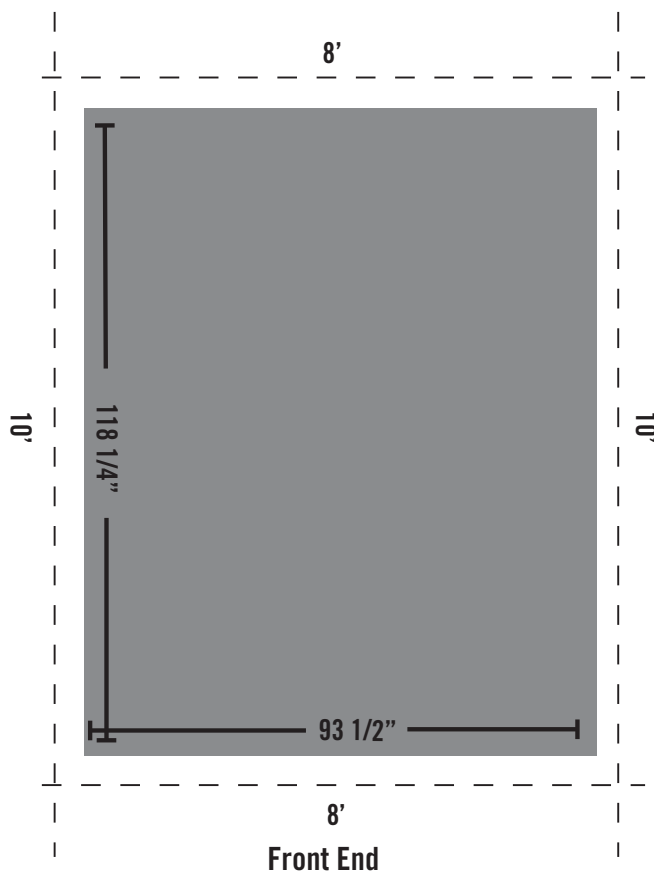

**!** *Note: Surface must be leveled before installation. If the surface is not properly leveled, the Outdoor Shed will not assemble or function correctly. Proper surface leveling will save you time in the long run, so please do not ignore this step.*

**!** *Note: Any platform or similar structure should be built above ground in order to avoid water pooling inside the Shed.*



## TOOLS AND HARDWARE REQUIRED FOR THIS PAGE

SEC 1



2" x 4" x 118 1/4" (x2) (Not included)

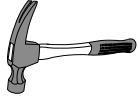

2" x 4" x 90 1/2" (x9) (Not included)

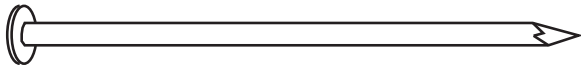

16d 3" Common Nail (x32) (Not included)

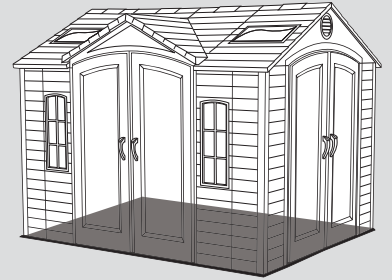

SEC

1.2

### ALTERNATIVE SITE PREPARATION: OPTION 1 - WOOD PLATFORM ASSEMBLY

Ensure all lumber used is treated and approved for outdoor use. Build outside frame to 93 1/2" x 118 1/4" outside dimensions:



*Note: Whenever possible, you should use the surfaces described on Page 7. When this is not possible, we recommend you use a wood platform or a filled wood frame.*

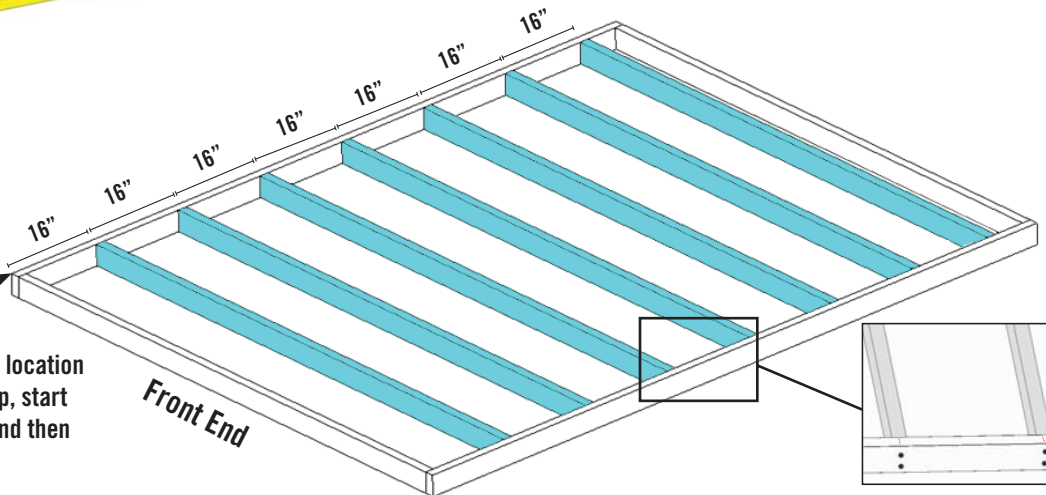
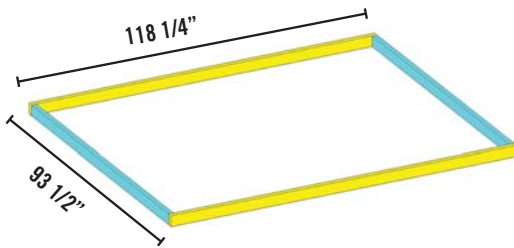

To ensure studs are in the correct location for nailing plywood in the next step, start measuring from the corner 16", and then measure from center to center.

Place the 2" x 4" x 90 1/2" boards on the inside of the frame. Nail each board in place with the 16d nails.



*Note: All lumber must be rated for outdoor use.*



*Note: Surface must be leveled before installation. If the surface is not properly leveled, the Outdoor Shed will not assemble or function correctly. Proper surface leveling will save you time in the long run, so please do not ignore this step.*



## TOOLS AND HARDWARE REQUIRED FOR THIS PAGE

SEC 1

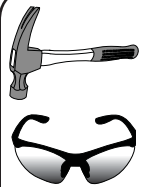

48" x 93 1/2" x 3/4" Treated Plywood (x2)  
(Not included)



22 1/4" x 93 1/2" x 3/4" Treated Plywood (x1)  
(Not included)

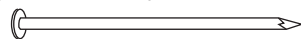

8d 1 1/2" Common Nail (x36)  
(Not included)

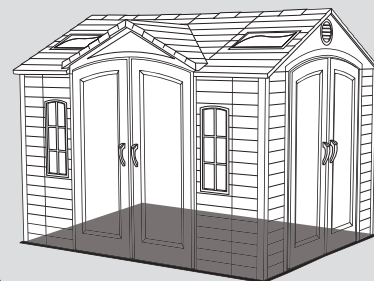

SEC

1.3

### ALTERNATIVE SITE PREPARATION: OPTION 1 - WOOD PLATFORM ASSEMBLY (CONT)

Square up the frame by measuring from corner to corner. Measurement A should equal Measurement B.

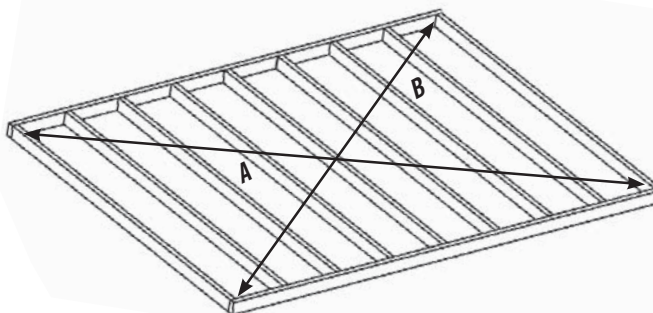

*Note: All lumber must be rated for outdoor use.*

SEC

1.4

Cut Plywood into sizes called for on previous page. Arrange the Plywood according to the diagram and nail into place with 8d x 1 1/2" nails. Place platform in the desired location. If platform does not rest level on the ground, build up low points with loose dirt until platform is stable. Drill three evenly spaced 1/2" drain holes in plywood between each 2" x 4" joist.

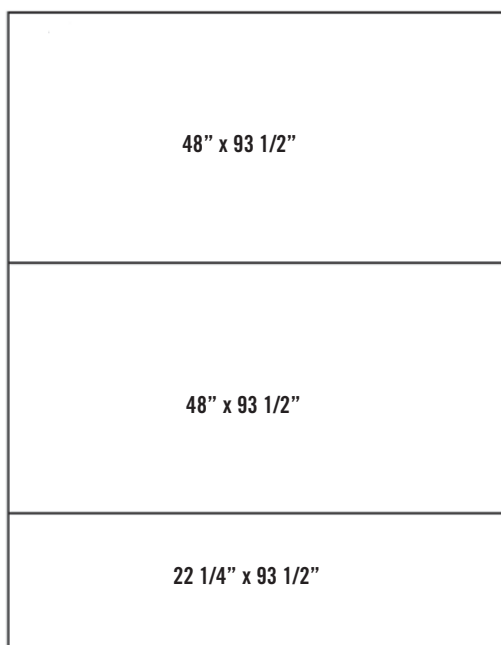

Front End



## TOOLS AND HARDWARE REQUIRED FOR THIS PAGE

SEC 1

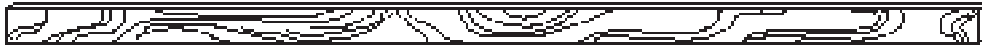

2" x 4" x 120" (x2) (Not included)

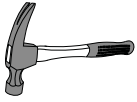

2" x 6" x 89" (x2) (Not included)



8d 1 1/2" Common Nail (x16)  
(Not included)



Pea Gravel (9.8 Cubic Feet)  
(Not included)

L-Bracket (x4)  
(Not included)

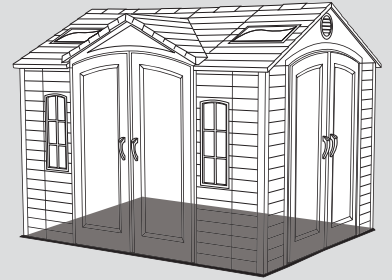

SEC

1.5

### ALTERNATIVE SITE PREPARATION: OPTION 2 - FILLED WOOD FRAME ASSEMBLY

Cut outside frame to 8' x 10' outside dimensions. Lay boards flat so widest parts face up. Ensure frame is level. Square up the frame by measuring from corner to corner. Measurement A should equal Measurement B. Nail an L-Bracket on each corner of the frame with 8d nails. Place platform in the desired location. If platform does not rest level on the ground, build up low points with loose dirt or "Pea" gravel, until platform is stable.



Note: Whenever possible you should use the surfaces described on Page 7.



Note: All lumber must be rated for outdoor use.

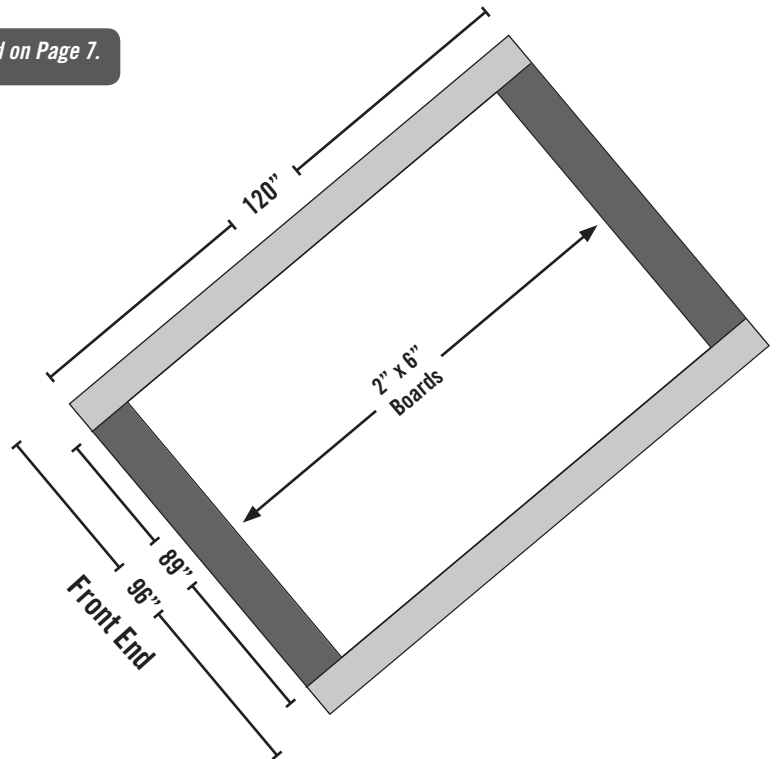
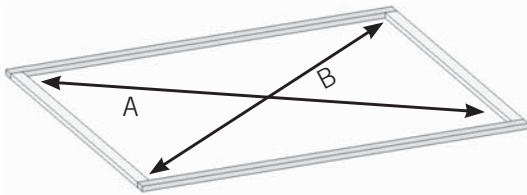

SEC

1.6

Once all boards are level and do not wobble, pack "Pea" gravel around the outside of the frame, and slope away from frame.

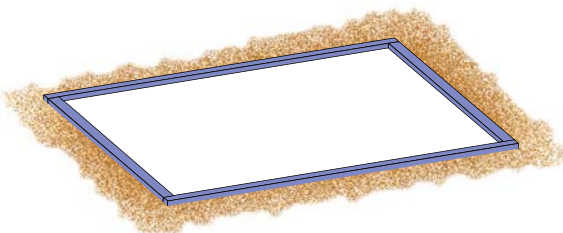

SEC

1.7

Now fill the inside of the frame with "Pea" gravel. Use a leveling board to scrape off extra fill material and to level the surface.

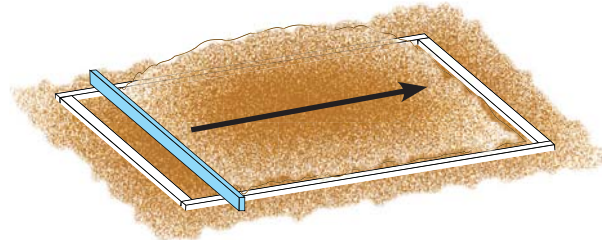

2" x 4" x 8' Leveling Board (x1)

## SEC 2 FLOOR ASSEMBLY

### HARDWARE REQUIRED

Parts shown at actual size

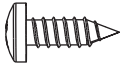

**BQC** (x20)  
#8 x 1/2" Pan-Head Screw  
(Only 12 used)

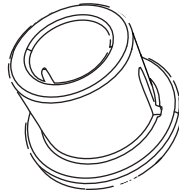

**AHO** (x4)  
Door Hinge Bushing

**HARDWARE BAG REQUIRED: CRC**

### METAL PARTS REQUIRED

**NO METAL PARTS REQUIRED FOR THIS SECTION**

### PLASTIC PARTS REQUIRED

Parts shown at 4% of actual size

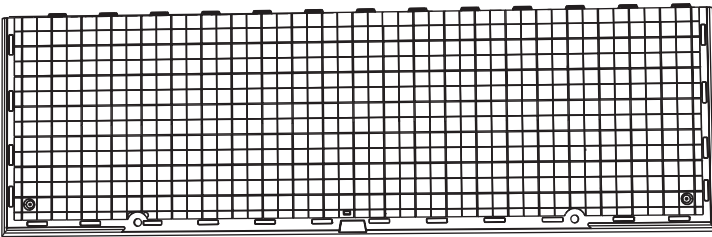

**AGR** (x2)  
Outer Floor Panel

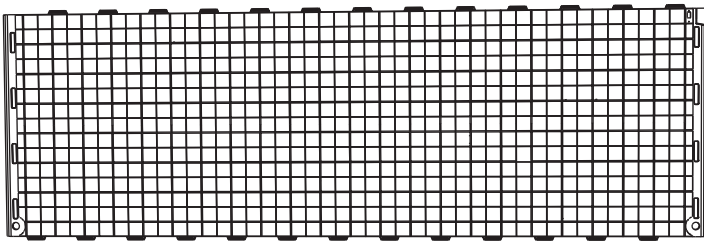

**AFX** (x2)  
Center Floor Panel

### TOOLS REQUIRED

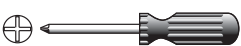

**Phillips Screwdriver**



**ADC** (x1)  
#2 Phillips Bit



**Safety Glasses**



## TOOLS AND HARDWARE REQUIRED FOR THIS PAGE

SEC 2



NO HARDWARE REQUIRED FOR THIS STEP

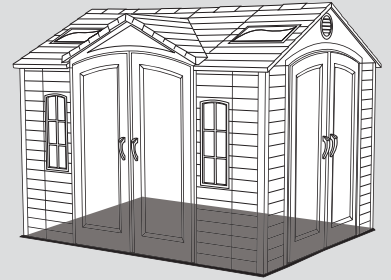

SEC

### FLOOR ASSEMBLY

2.1

Lay an **Outer Floor Panel (AGR)** flat on the ground. Hold a **Center Floor Panel (AFX)** at an angle as shown and fit tabs into slots. Lay Center Floor Panel flat.

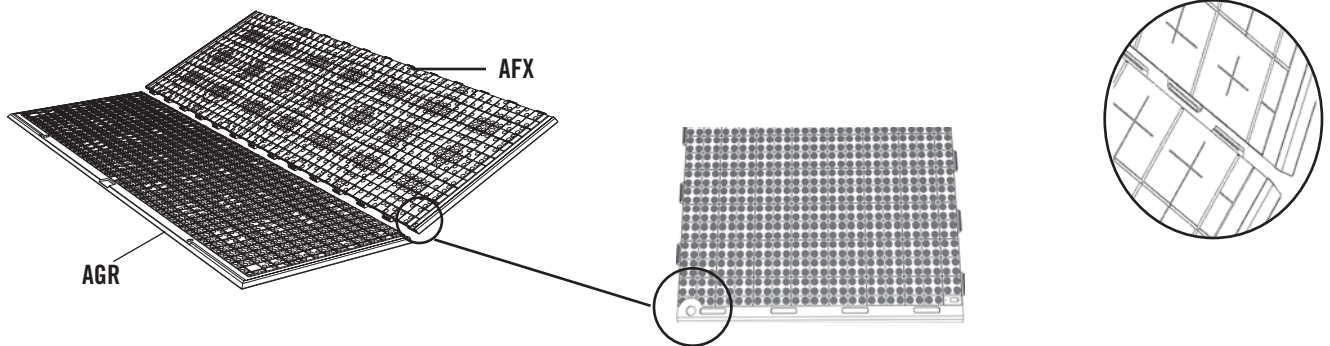

*Note: Ensure you insert the Inner Floor Panel (AFX) with the Door Hinge Bushing Holes toward the outside. You'll place the Doors here later.*

SEC

2.2

Hold the second **Center Floor Panel (AFX)** at an angle as shown and fit tabs into slots. Lay Center Floor Panel flat.

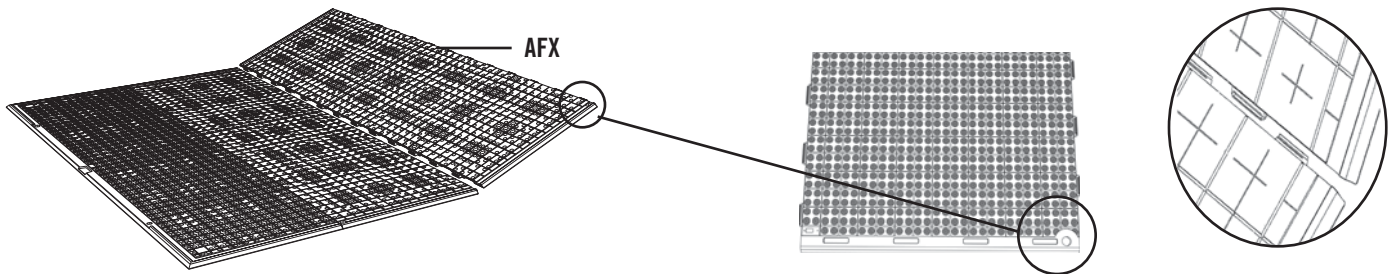

*Note: Ensure you insert the Inner Floor Panel (AFX) with the Door Hinge Bushing Holes toward the outside. You'll place the Doors here later.*



### CAUTION

Sharp objects may damage your floor. If resting sharp, heavy objects on your shed floor, place a block of wood between the sharp object and floor.



## TOOLS AND HARDWARE REQUIRED FOR THIS PAGE

SEC 2



NO HARDWARE REQUIRED FOR THIS STEP

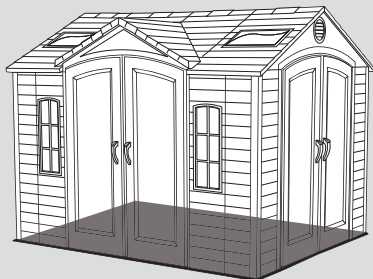

SEC

2.3

Finally, connect the last **Outer Floor Panel (AGR)** to the Center Floor Panel and lay flat.

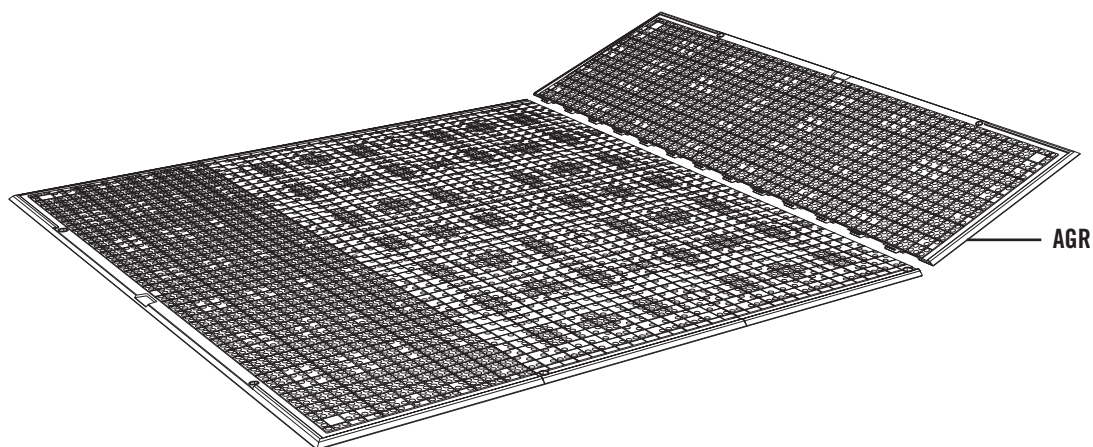

SEC

2.4

Decide where you would like the second set of doors placed (left side or right side). In the example below, we've placed the second set of doors on the right side of the shed; however, place them on the side you wish.

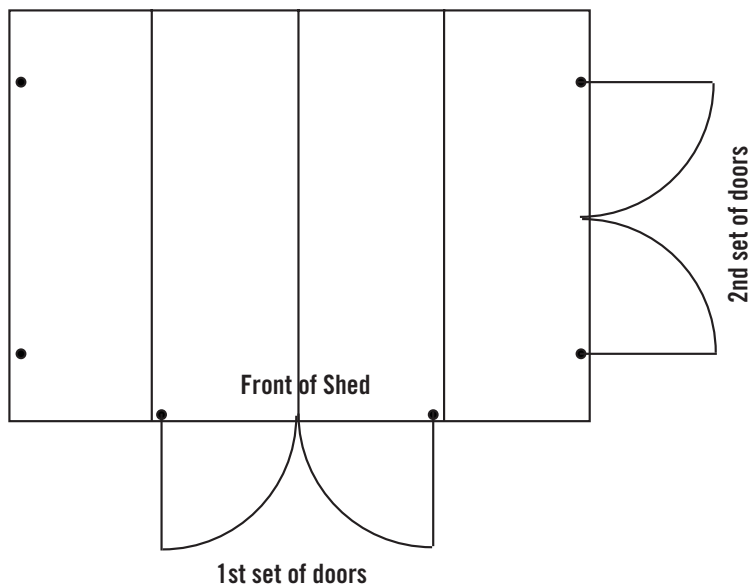



## TOOLS AND HARDWARE REQUIRED FOR THIS PAGE

SEC 2

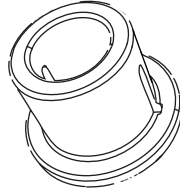

AHO (x4)

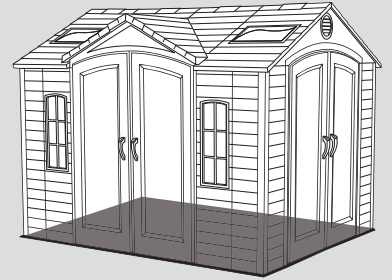

SEC

2.5

Lift the Floor Panels up enough to slide the **Door Hinge Bushings (AHO)** under and up through the holes in the Floor Panels as shown.

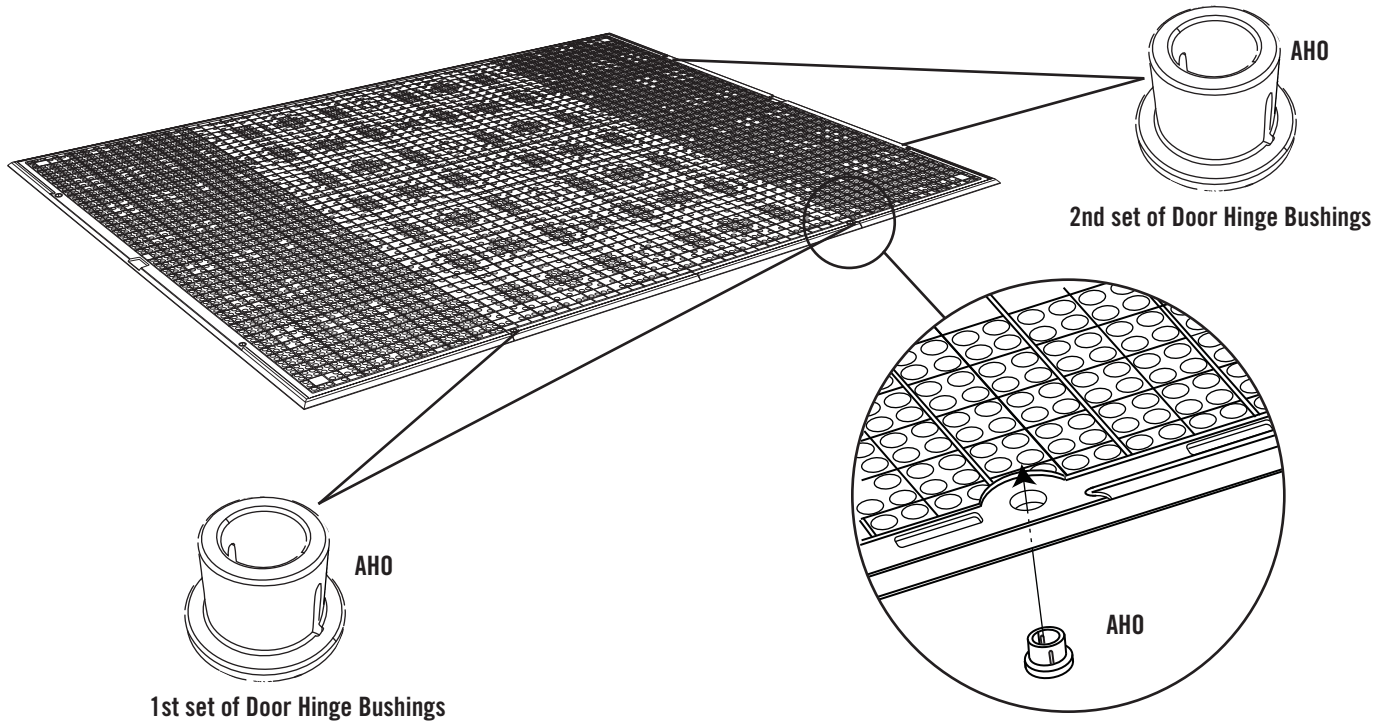

*Note: In the example above, we indicate inserting the second set of Door Hinge Bushings on the right side of the shed; however, they can be inserted on the left if that is where you want your doors.*





## TOOLS AND HARDWARE REQUIRED FOR THIS PAGE

SEC

2

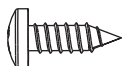

**BQC** (x20)  
(Only 12 used)

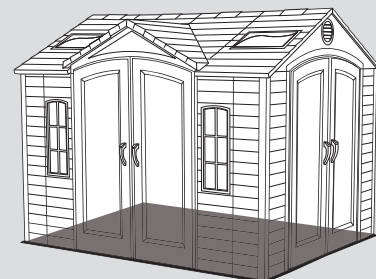

SEC

2.6

Face the seam of two adjacent Floor Panels. Insert two (2) **#8 x 1/2" Pan-Head Screws (BQC)** near the seam of a Floor Panel and down into the tab of the adjacent Floor Panel at the locations shown. Repeat this step for each seam in the Floor.

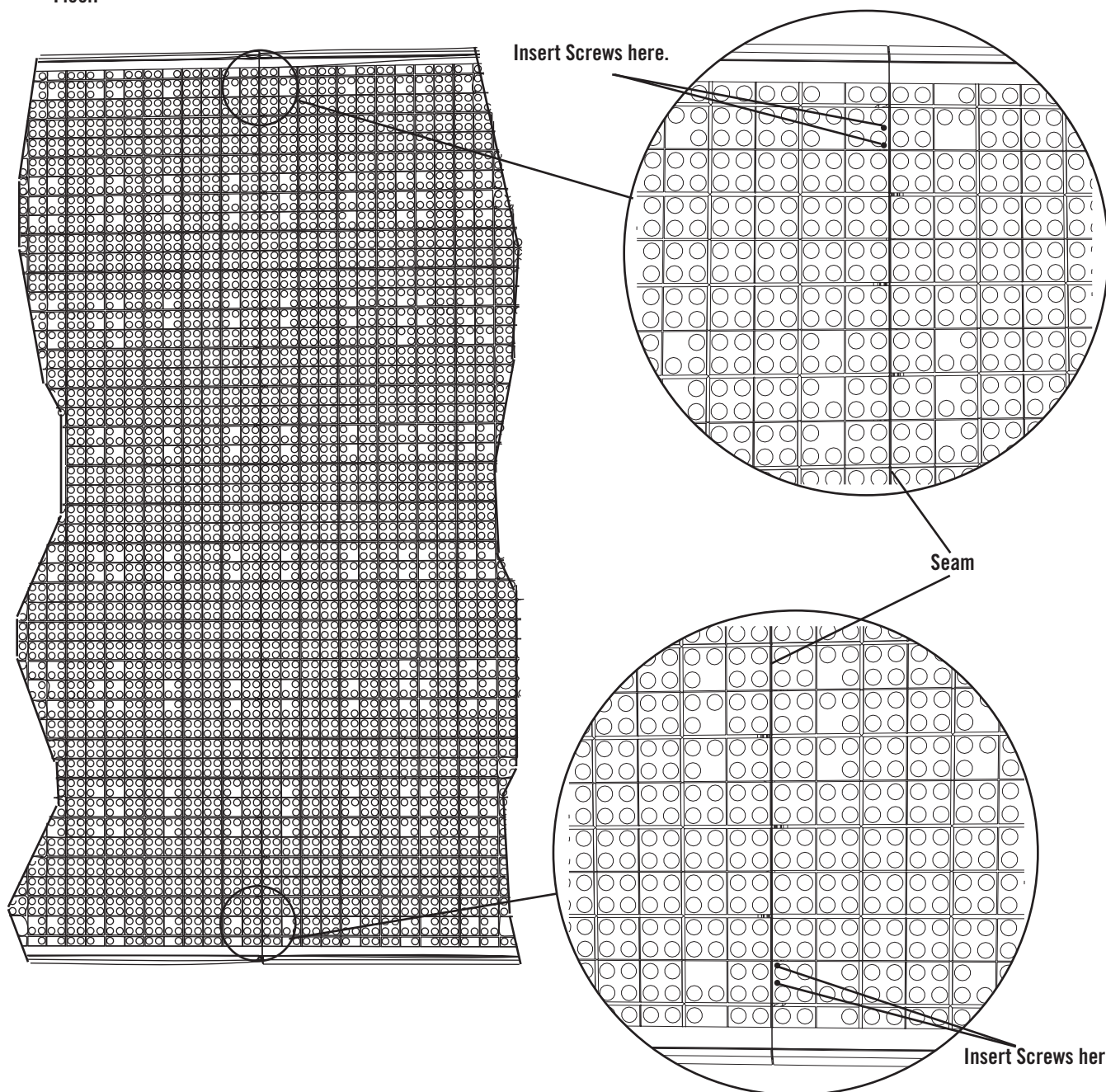



## TOOLS AND HARDWARE REQUIRED FOR THIS PAGE

SEC 2



**IF YOU PLAN ON ANCHORING YOUR SHED, CHECK WITH YOUR LOCAL HARDWARE STORE FOR SUITABLE HARDWARE.**

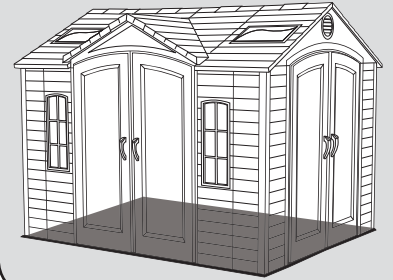

SEC

2.7

### ANCHORING THE SHED

If you plan on anchoring your shed, you can anchor it to your platform through the four indentations near the corners of the floor. The anchoring hardware used depends on the platform. If you have a concrete platform, we recommend using four (4) 3/8" Anchor Bolts and four (4) 3/8" x 1" Flat Washers. If you have a wood framed platform, we recommend using four (4) 3/8" Lag Bolts and four (4) 3/8" x 1" Flat Washers. Do not exceed a 3/8" diameter bolt. Refer to your local hardware store for this hardware. **Do not tighten the anchoring hardware until instructed to do so at the end of these instructions.**

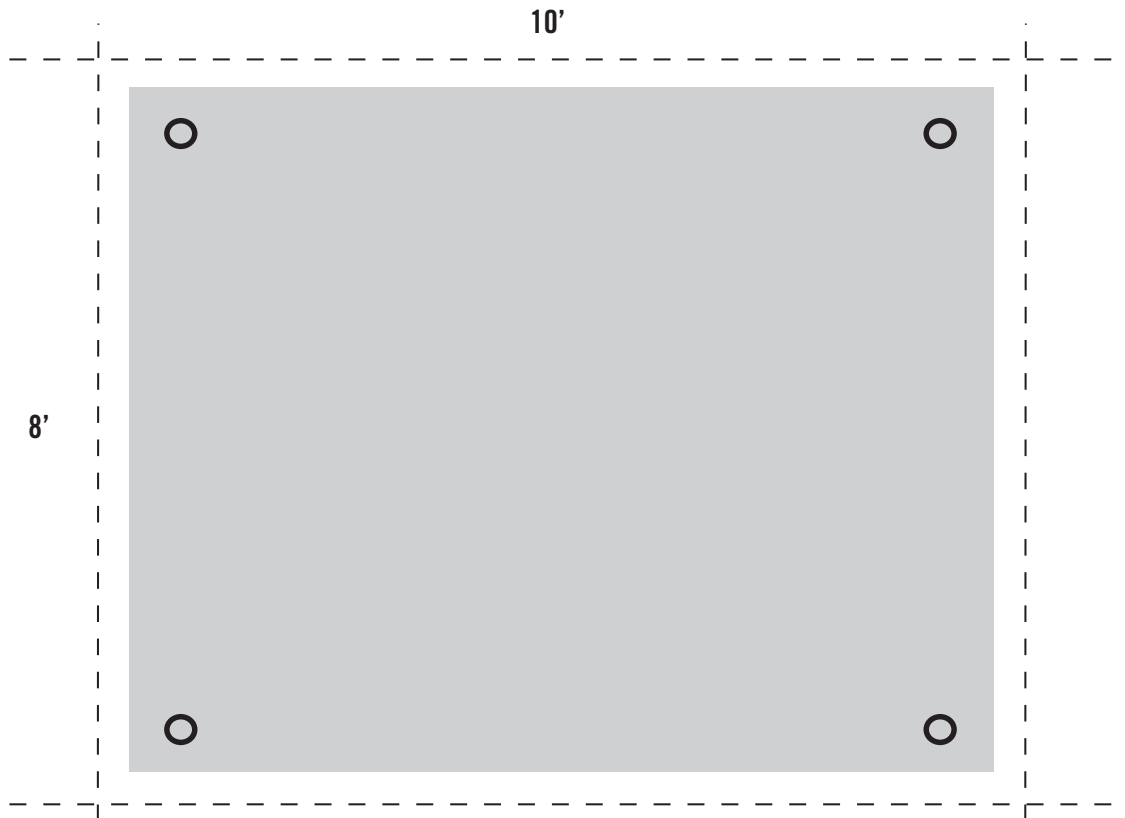

### WARNING

Failure to anchor the shed may result in property damage and/or personal injury.

# SEC 3 TRUSS ASSEMBLY

## HARDWARE REQUIRED

## HARDWARE BAG REQUIRED: BEA

Hardware shown at actual size (\*Unless indicated otherwise)

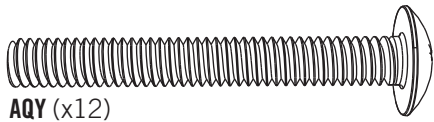

**AQY** (x12)  
1/4" x 2" Truss Screw

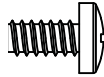

**ADY** (x12)  
#10 x 3/8" Screw



**ADJ** (x18)  
1/4" Cap Nut



**ADK** (x12)  
#10 Cap Nut

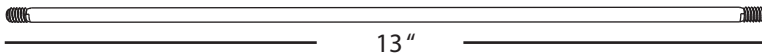

\***ADH** (x3) 1/4" Threaded Rod

## METAL PARTS REQUIRED

Parts shown at 8% of actual size (\*Unless indicated otherwise)

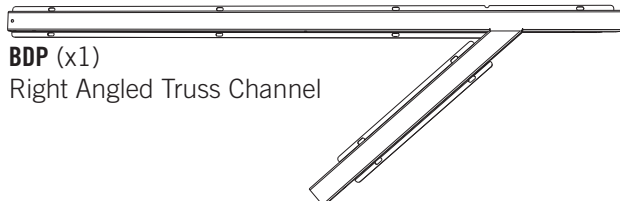

**BDP** (x1)  
Right Angled Truss Channel

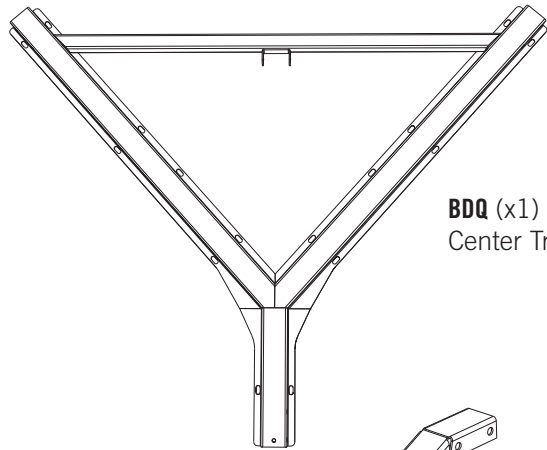

**BDQ** (x1)  
Center Truss Channel

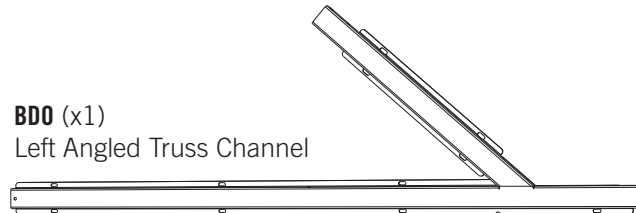

**BDO** (x1)  
Left Angled Truss Channel

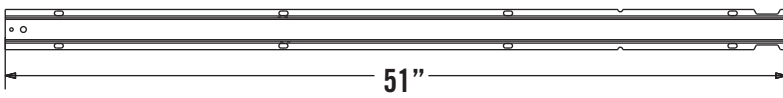

**AFH** (x3)  
Truss Gutter Channel

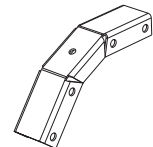
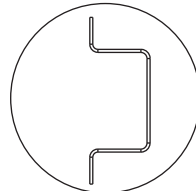

**AQX** (x3)\*  
Truss Connector



**AFG** (x3)  
Roof Truss Brace (Not to Scale)

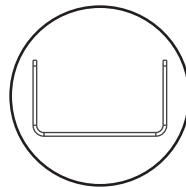

## TOOLS REQUIRED

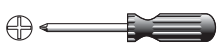

Phillips Screwdriver



7/16" Wrench (x2)



3/8" Wrench



Safety Glasses



## TOOLS AND HARDWARE REQUIRED FOR THIS PAGE

SEC 3



7/16"

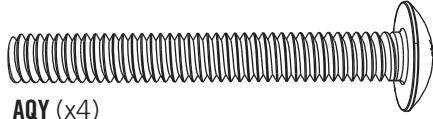

AQY (x4)



ADJ (x4)

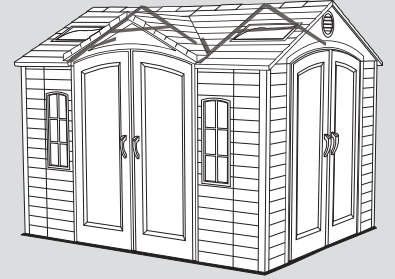

SEC

### SIDE ANGLED TRUSS ASSEMBLY

3.1

Stand the **Left Angled Truss Channel (BDO)** upright and set a **Truss Connector (AQX)** inside the end of the Left Angled Truss Channel as shown. Align the holes and secure with two (2) **1/4" x 2" Phillips Truss Screws (AQY)** and two (2) **1/4" Cap Nuts (ADJ)**.

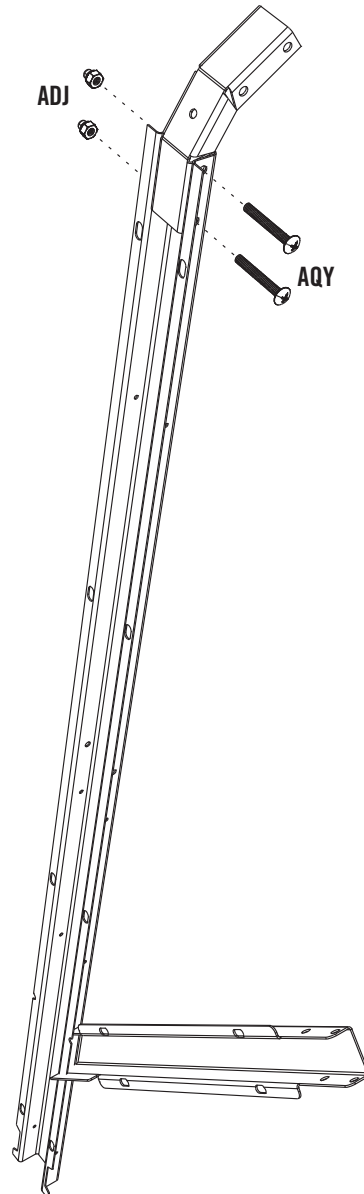
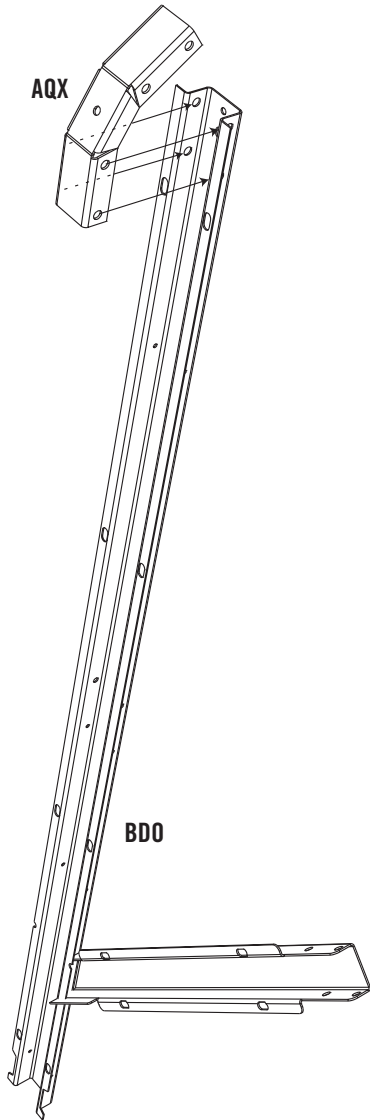



# TOOLS AND HARDWARE REQUIRED FOR THIS PAGE

SEC. 3



7/16"

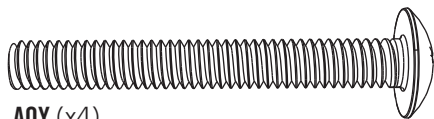

AQY (x4)



ADJ (x4)

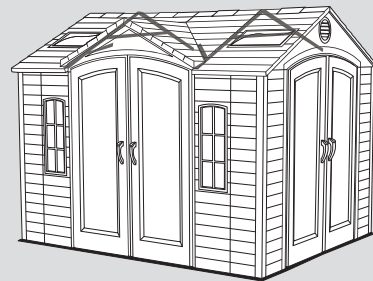

SEC

3.2

Connect a **Truss Gutter Channel (AFH)** to the Truss Connector using two (2) **1/4" x 2" Phillips Truss Screws (AQY)** and two (2) **1/4" Cap Nuts (ADJ)**.

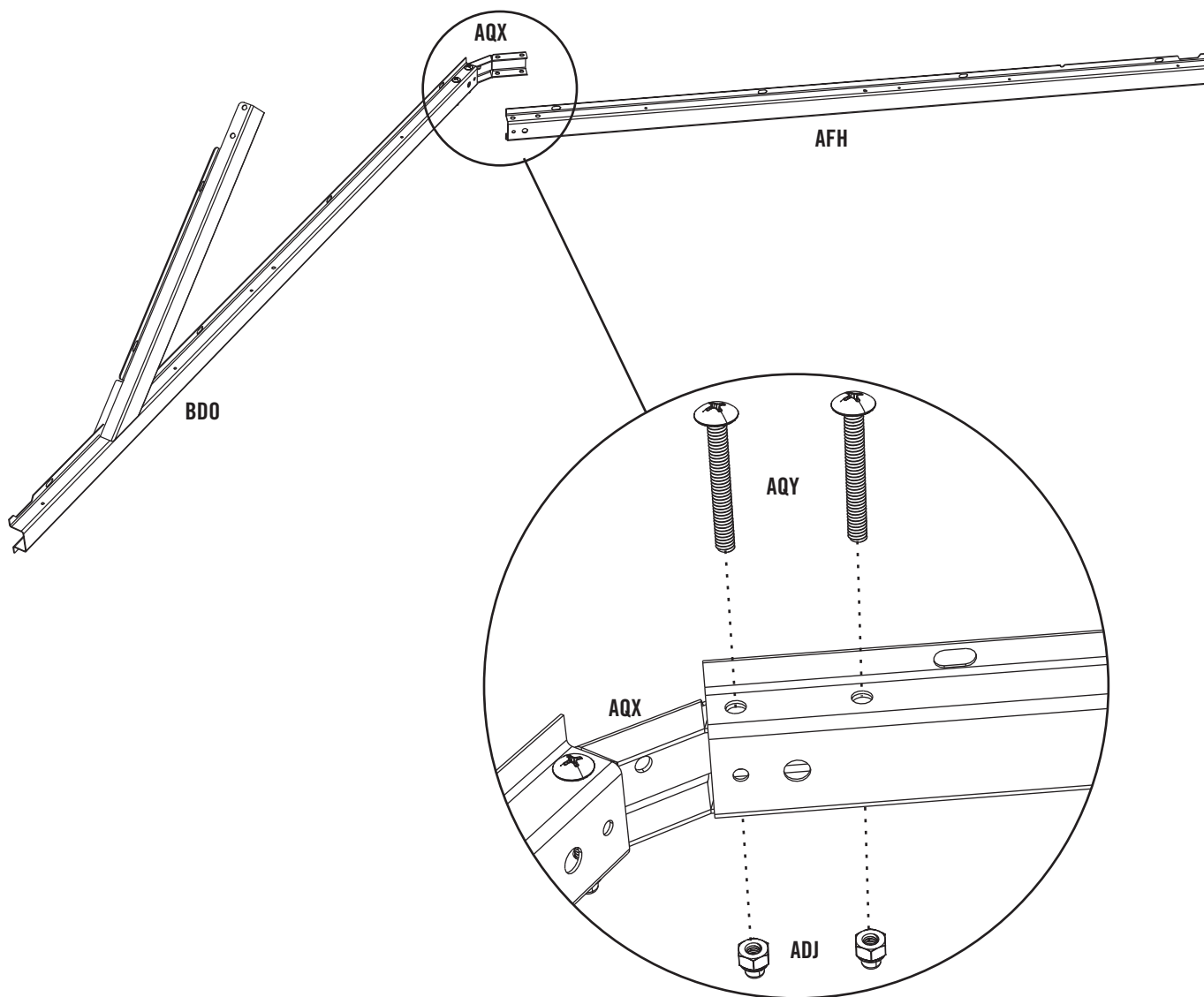



## TOOLS AND HARDWARE REQUIRED FOR THIS PAGE

SEC 3



3/8"

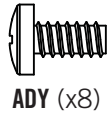

ADY (x8)



ADK (x8)

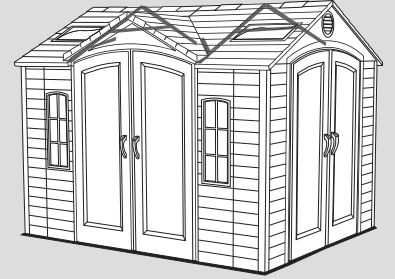

SEC

3.3

With the Angled Truss Assembly on its side, align the holes in a **Roof Truss Brace (AFG)** with those circled in the Left Angled Truss Channel and Truss Gutter Channel as shown.

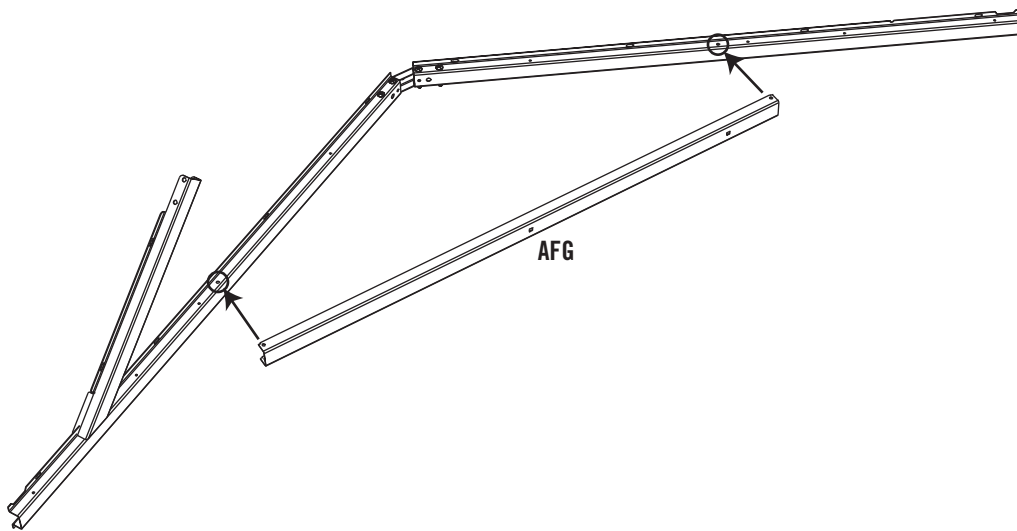

SEC

3.4

Secure the Roof Truss Brace to the Left Angled Truss Channel using two (2) #10 x 3/8" Pan-Head Screws (ADY) and two (2) #10 Cap Nuts (ADK). Repeat this step for the other end of the Roof Truss Brace.

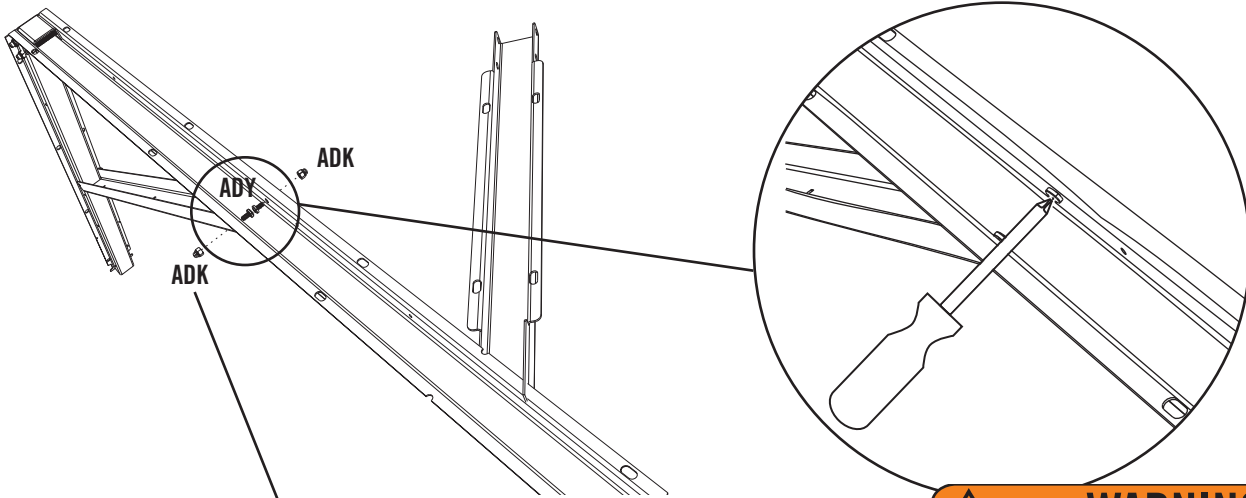

*Note: The Cap Nuts goes on the outside of the Truss.*



### WARNING

Do not overtighten the Cap Nut. If the end of the Bolt breaks through the plastic cap, call our Customer Service Department. Exposed threads on the end of the Bolt may cause serious injuries.



## TOOLS AND HARDWARE REQUIRED FOR THIS PAGE

SEC. 3

7/16" (x2)



ADJ (x4)

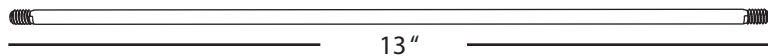

ADH (x2) (Not to scale)

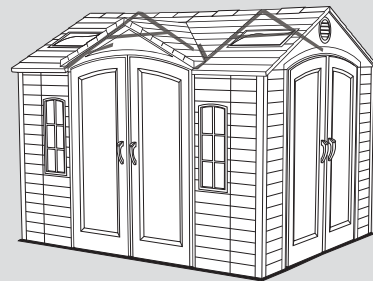

SEC

3.5

With the Angled Truss Assembly on its side, slide a **1/4" Threaded Rod (ADH)** through the Roof Truss Brace and the Truss Connector as shown. Secure the top and bottom of the 1/4" Threaded Rod with a **1/4" Cap Nut (ADJ)**. Tighten all hardware. The 1/4" Threaded Rod will still spin freely. Set aside. **Repeat previous steps for the Right Angled Truss Assembly.**

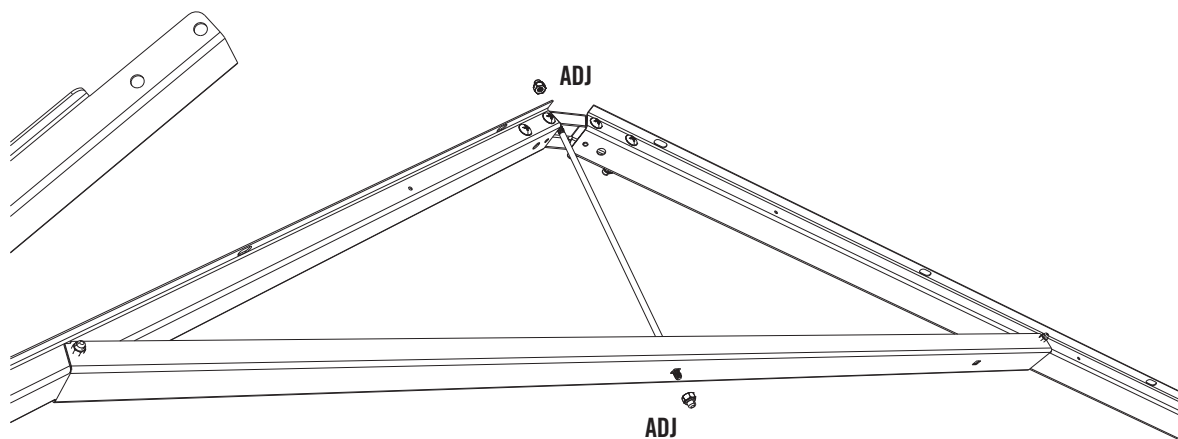
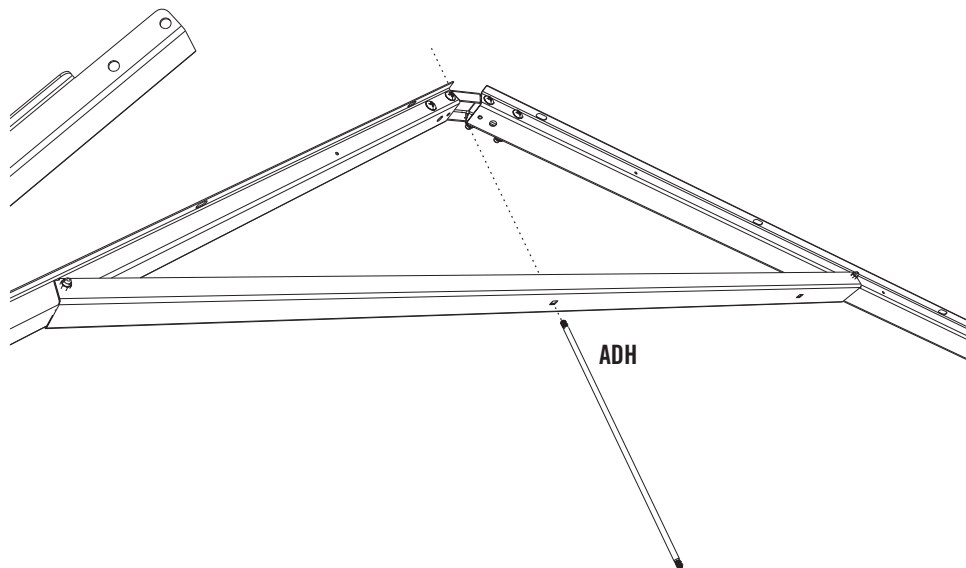

**WARNING**

Do not overtighten the Cap Nut.



## TOOLS AND HARDWARE REQUIRED FOR THIS PAGE

SEC 3

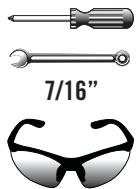

7/16"

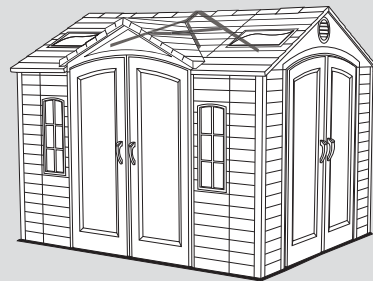

SEC

### CENTER ANGLED TRUSS ASSEMBLY

3.6

Attach a **Truss Connector (AQX)** to the **Center Angled Truss Channel (BDQ)** using the hardware shown.

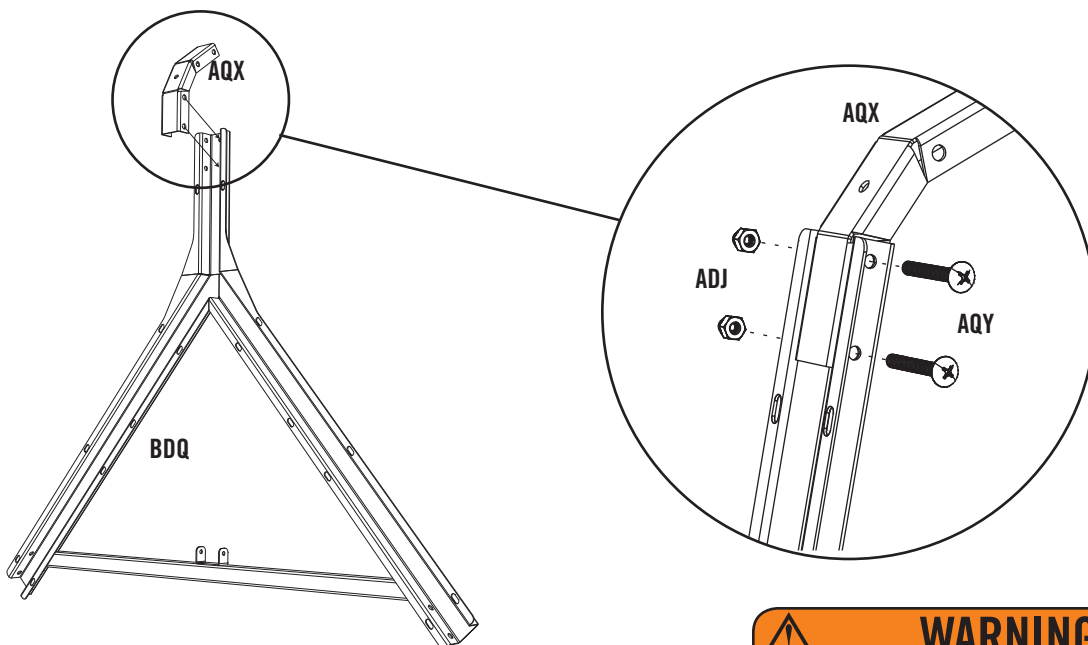

**WARNING**

Do not overtighten the Cap Nut.

SEC

3.7

Attach a **Truss Gutter Channel (AFH)** to the Truss Connector using the hardware shown.

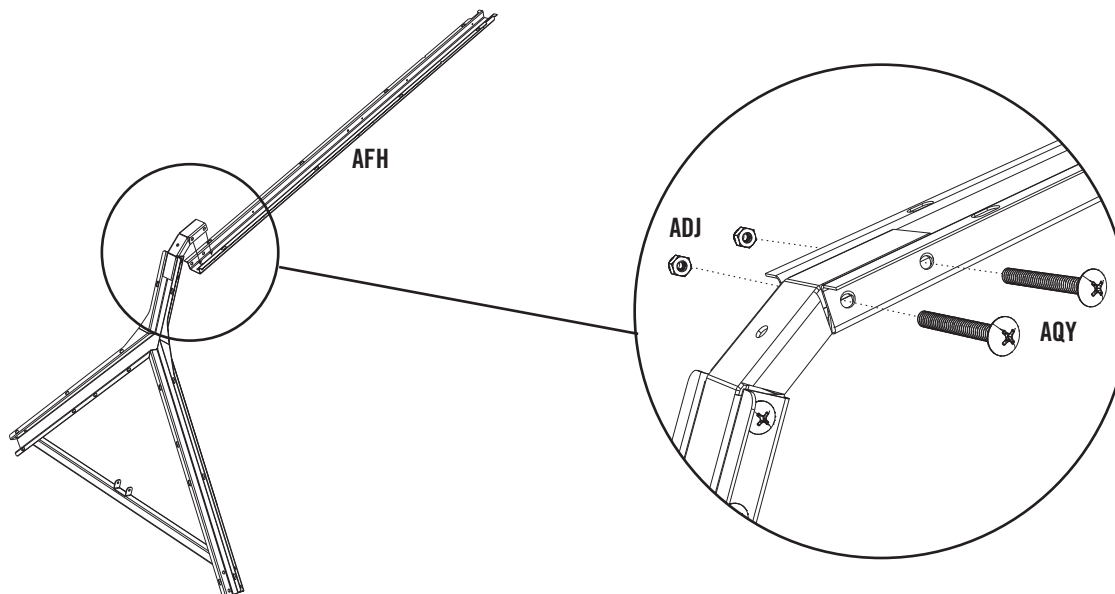





# TOOLS AND HARDWARE REQUIRED FOR THIS PAGE

SEC. 3



3/8"

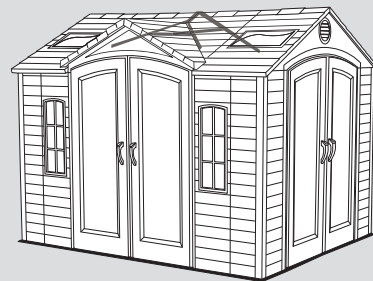

SEC

3.8

Align the hole in the Roof Truss Brace with that circled on the Truss Gutter Channel in the image below. Attach a Roof Truss Brace (AFG) to the Center Truss Assembly using the hardware shown.

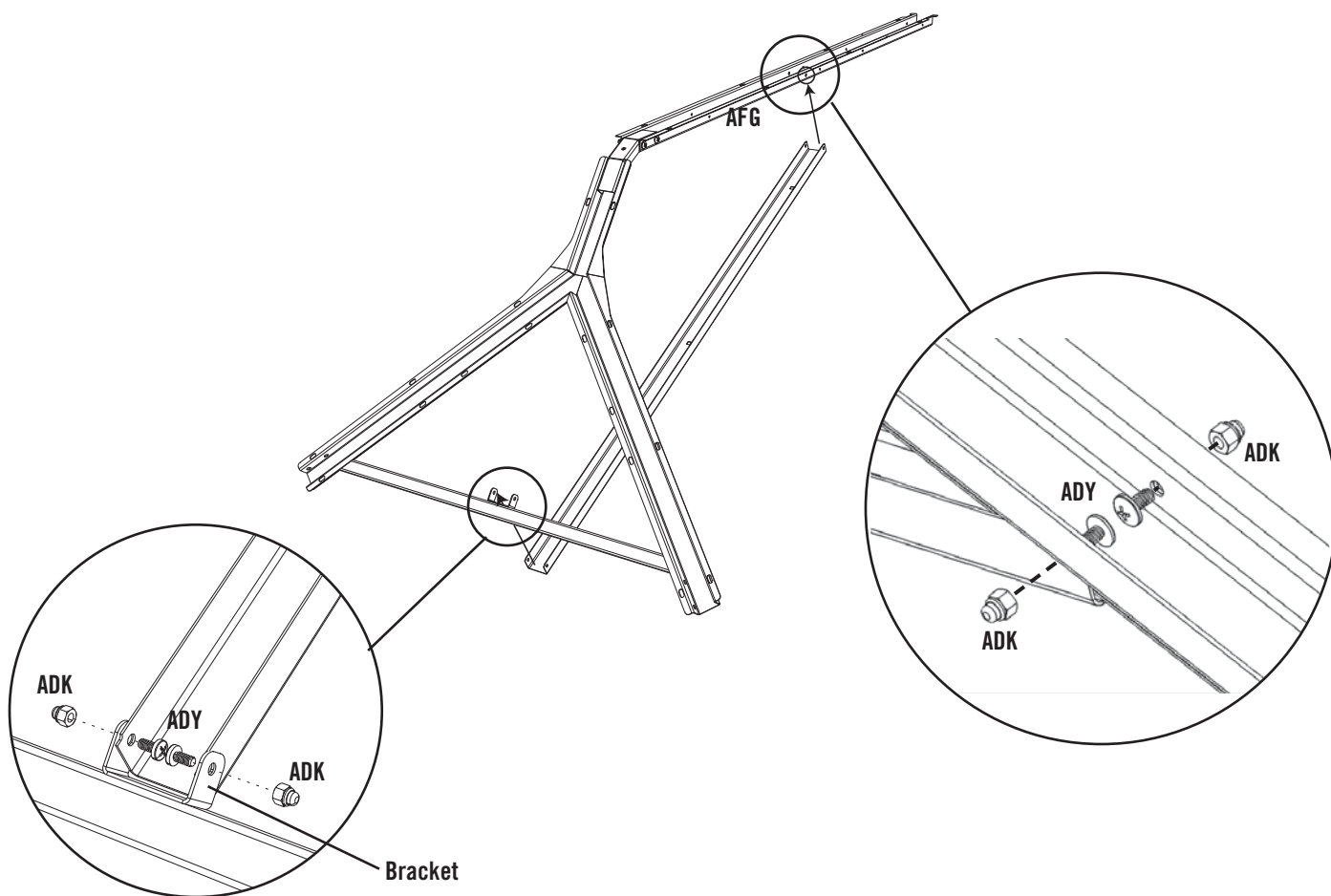

**!** Note: The Roof Truss Brace goes inside the bracket.

**WARNING**  
Do not overtighten the Cap Nut.



## TOOLS AND HARDWARE REQUIRED FOR THIS PAGE

SEC 3



7/16" (x2)



ADJ (x2)

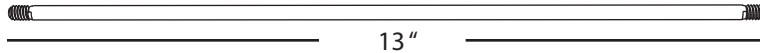

ADH (x1) (Not to scale)

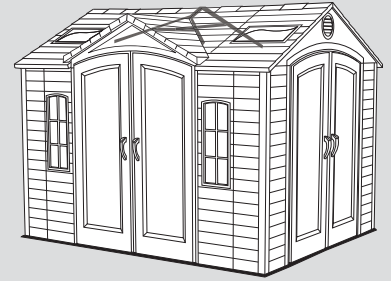

SEC

3.9

Insert a **1/4" Threaded Rod (ADH)** through the Roof Truss Brace and Truss Connector as shown. Ensure channels are parallel, then secure with **1/4" Cap Nuts (ADJ)**. Tighten all hardware. The 1/4" Threaded Rod will still spin freely. Set aside.

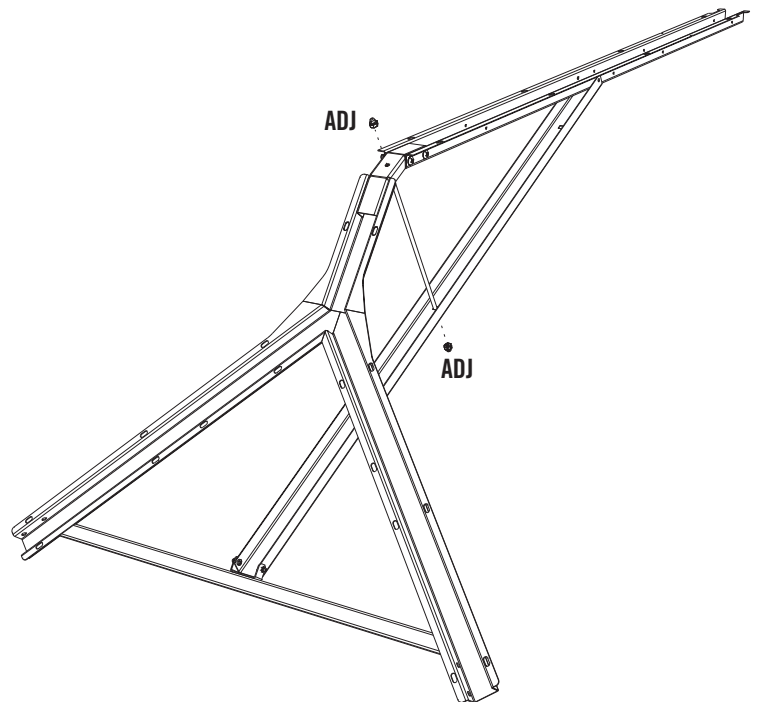
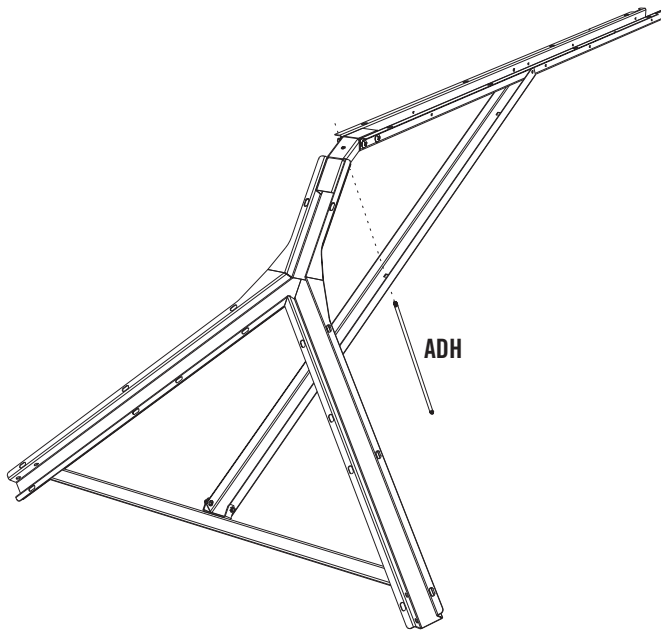

**WARNING**

Do not overtighten the Cap Nut.

## SEC 4 WALL PANEL INSTALLATION

### HARDWARE REQUIRED

Hardware shown at actual size

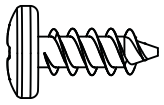

**ADZ** (x85)  
1/4" x 5/8" Pan-Head Screw  
(Not all screws will be used)

### HARDWARE BAG REQUIRED: BEB

### METAL PARTS REQUIRED

Part shown at 8% of actual size

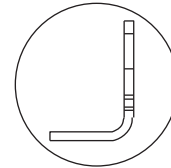
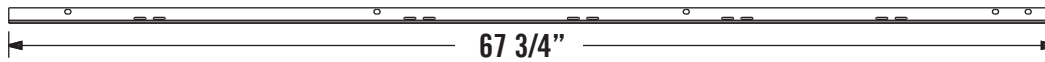

**AFM** (x2)  
Wall Support Channel

### PLASTIC PARTS REQUIRED

Part shown at 4% of actual size

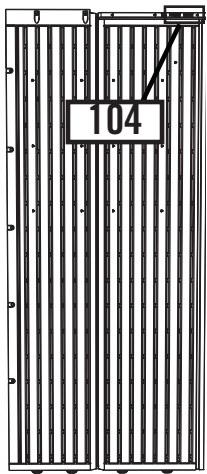

**AGY** (x1)  
Corner Wall Panel 104

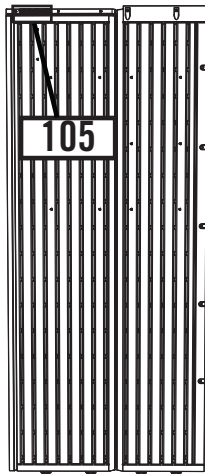

**AGN** (x1)  
Corner Wall Panel 105

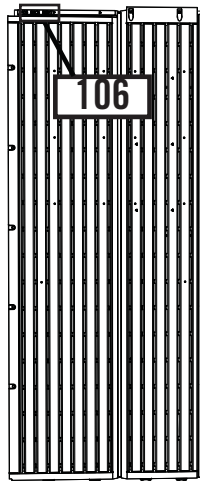

**AGW** (x1)  
Corner Wall Panel 106

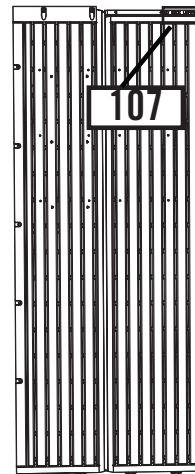

**AGL** (x1)  
Corner Wall Panel 107

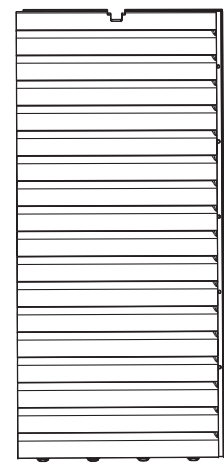

**AHD** (x4)  
Wall Panel



*Note: Pay no attention to the imprinting of "Left" or "Right" on the Corner Wall Panels.*



**AHH** (x1)  
Window Wall Panel

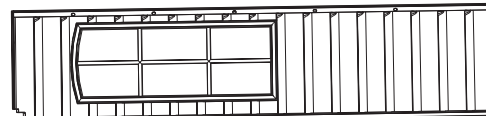

**BDI** (x1)  
Right Half-Window Wall Panel

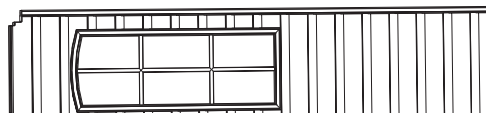

**BDH** (x1)  
Left Half-Window Wall Panel

### TOOLS REQUIRED



Phillips Screwdriver



Safety Glasses



**AIW** (x1)  
Wood Block (Included)

### PARTS KIT REQUIRED: BOD



## TOOLS AND HARDWARE REQUIRED FOR THIS PAGE

SEC 4



AIW (x1)

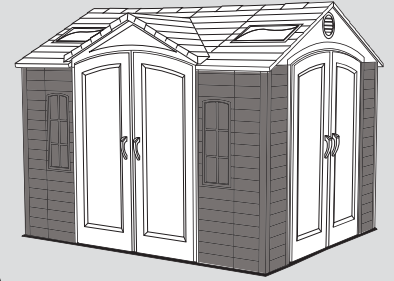

SEC

4.1

### WALL PANEL INSTALLATION

Fold a **Corner Wall Panel 107 (AGL)**. Fit tabs of Panel into the front, left corner of your Floor (while facing shed). Place a **Wood Block (AIW)** under floor panel, directly under the first tab, then pull down on the Corner Panel until the tab snaps into place. Move the Wood Block under the next tab and repeat.

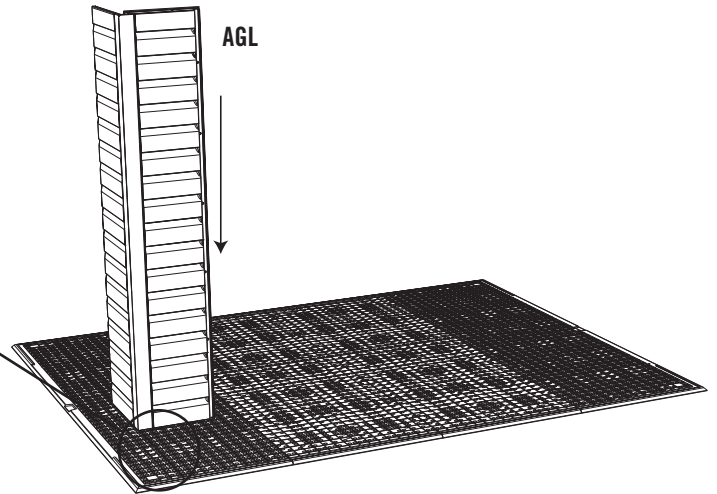
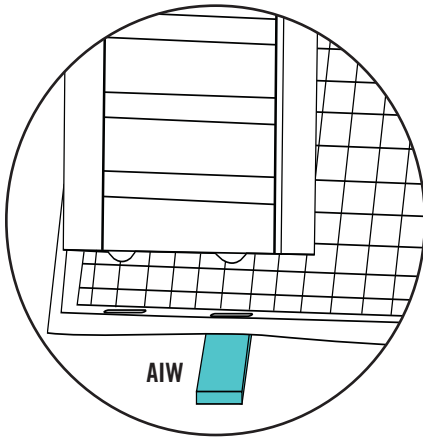

SEC

4.2

Snap **Wall Panels (AHD)** into place along the short side of shed. Ensure the tops of the Wall Panels are even and the holes align. Use one (1) **1/4" x 5/8" Pan-Head Screw (ADZ)** to fasten the top of the Panels together as shown. **Repeat this step for the next Wall Panel (AHD).** You'll finish fastening the panels together towards the end of this section.

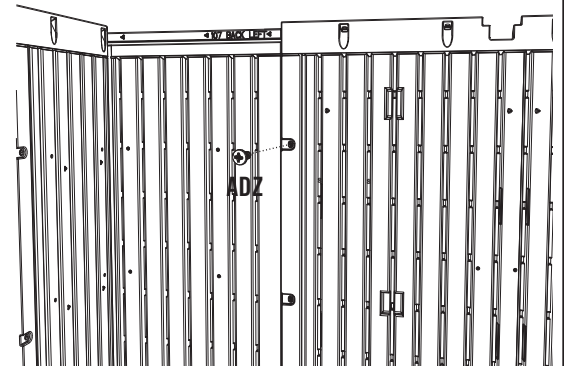
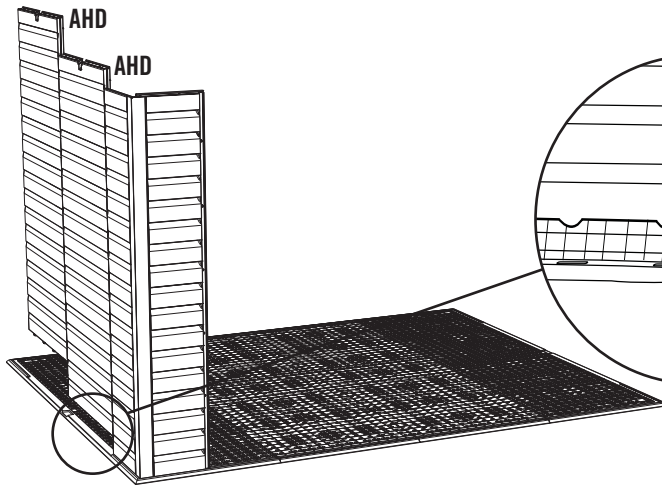

*Note: A second person should apply pressure on opposite side of the Wall Panels for easier insertion of the Screw. Do not overtighten Screw.*



## TOOLS AND HARDWARE REQUIRED FOR THIS PAGE

SEC. 4



AIW (x1)

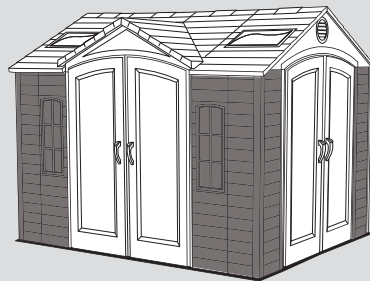

SEC

4.3

Fold a **Corner Wall Panel 106 (AGW)**. Snap into place and fasten at the top hole with the required hardware.

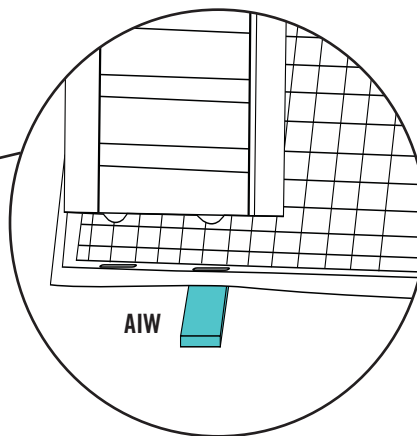
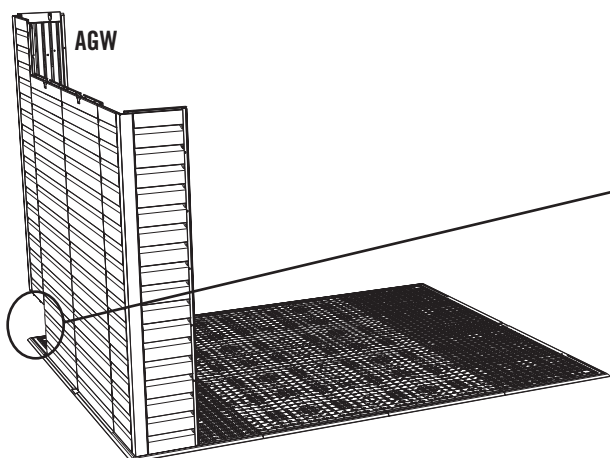

*Note: Place the Wood Block (AIW) directly under the tabs as you insert them throughout the assembly. Snap tabs into place one at a time.*

SEC

4.4

Insert two **Wall Panels (AHD)** and a **Window Wall Panel (AHH)** along back side of shed. The Window Wall Panel may be placed in any rear Wall Panel position. Ensure holes line up and fasten Panels at the top hole with the required hardware.

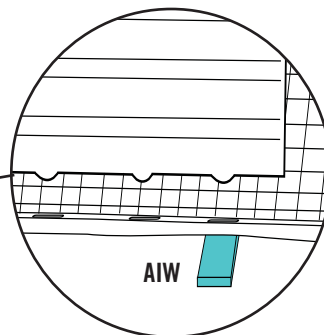
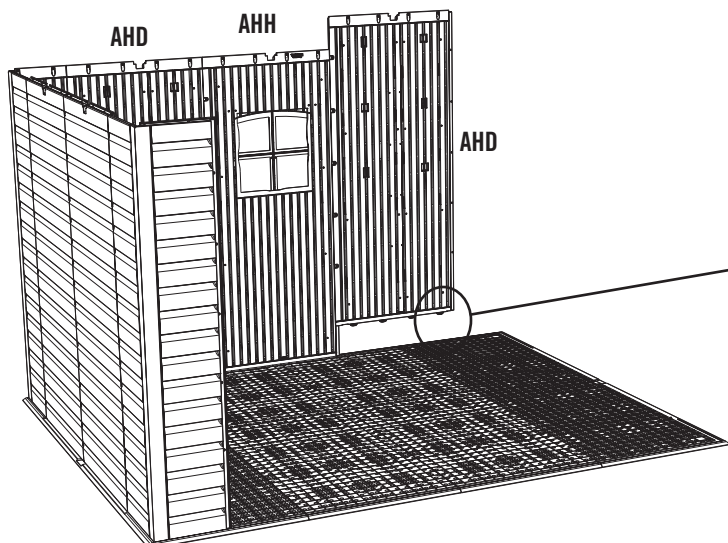

*Note: A second person should apply pressure on opposite side of the Wall Panels for easier insertion of the Screws. Do not overtighten Screws.*



# TOOLS AND HARDWARE REQUIRED FOR THIS PAGE

# SEC 4



AIW (x1)

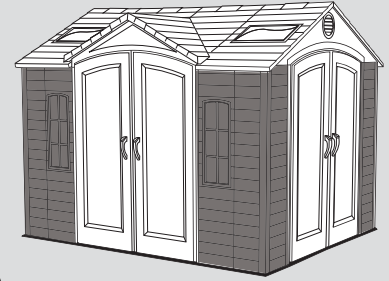

# SEC

# 4.5

Fold a **Corner Wall Panel 104 (AGY)** and fasten to the rear Wall Panel in the top hole using the required hardware. Snap the last **Corner Wall Panel 105 (AGN)** in the front, right corner position.

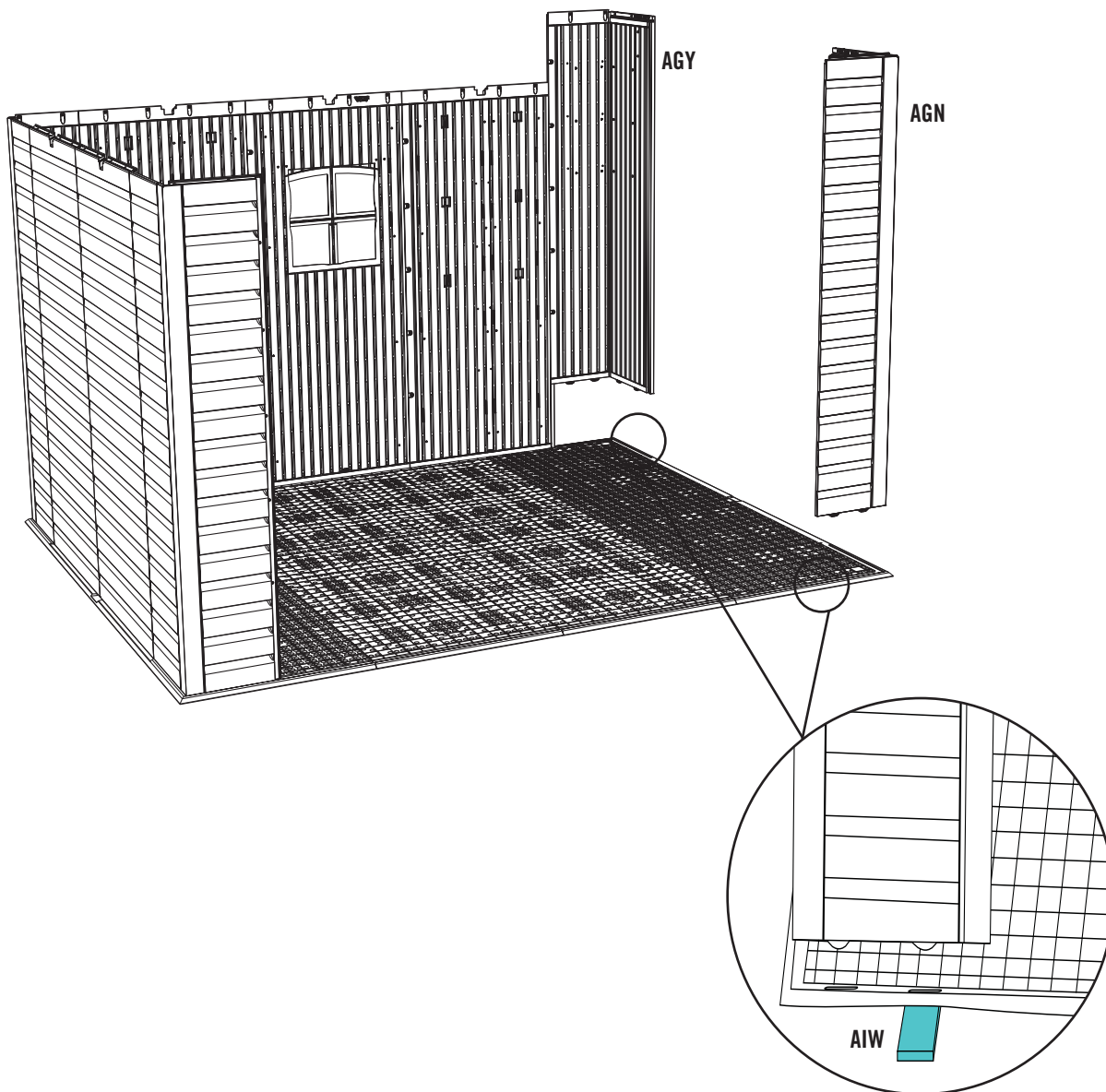

*Note: Place the Wood Block (AIW) directly under the tabs as you insert them throughout the assembly. Snap tabs into place one at a time.*



## TOOLS AND HARDWARE REQUIRED FOR THIS PAGE

SEC. 4



AIW (x1)

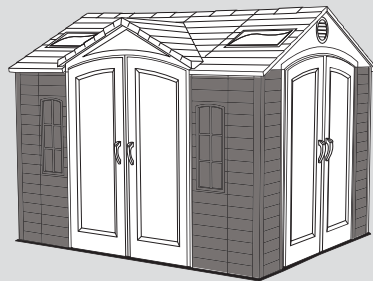

SEC 4.6

.....  
Snap the **Right** and **Left Half-Window Wall Panels (BDI & BDH)** into place along the front of the Shed. After ensuring holes line up, fasten Panels together with the required hardware. Finish fastening all Panels together with rest of the **1/4" x 5/8" Pan-Head Screws (ADZ)** for all holes.

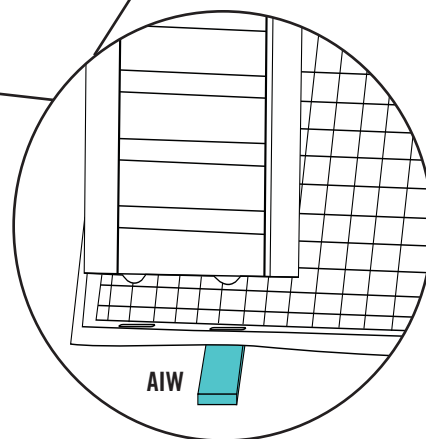
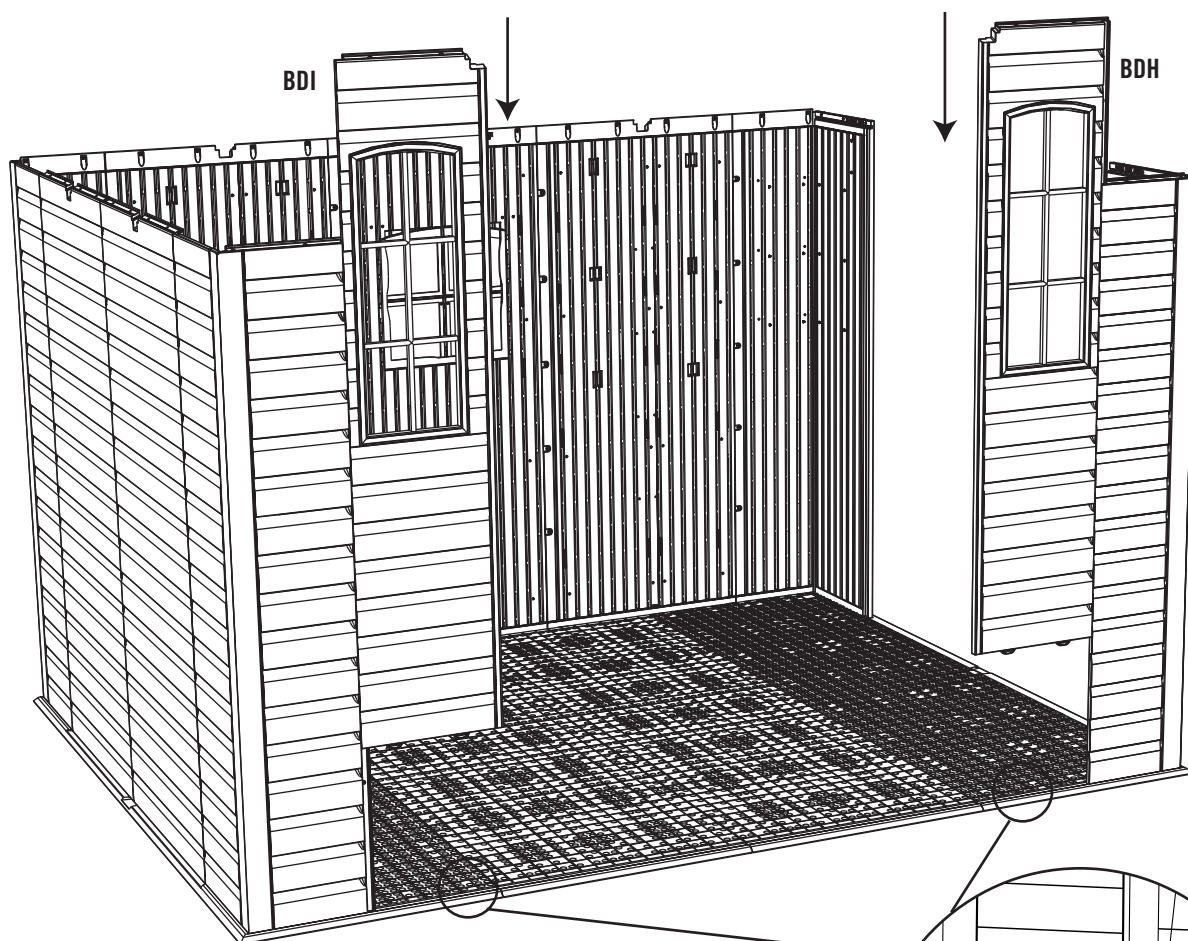

*Note: Place the Wood Block (AIW) directly under the tabs as you insert them throughout the assembly. Snap tabs into place one at a time.*



*Note: A second person should apply pressure on opposite side of the Wall Panels for easier insertion of the Screws. Do not overtighten Screws.*



# TOOLS AND HARDWARE REQUIRED FOR THIS PAGE

SEC 4

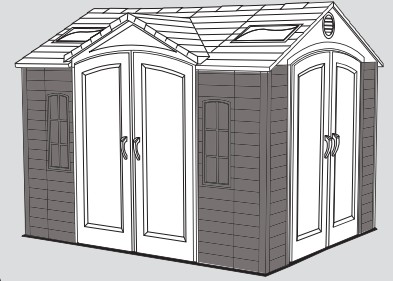

SEC

4.7

Attach a **Wall Support Channel (AFM)** to the Right Half-Window Wall Panel, and secure with four (4) **1/4" x 5/8" Pan-Head Screws (ADZ)**.

Use 2nd groove from the right

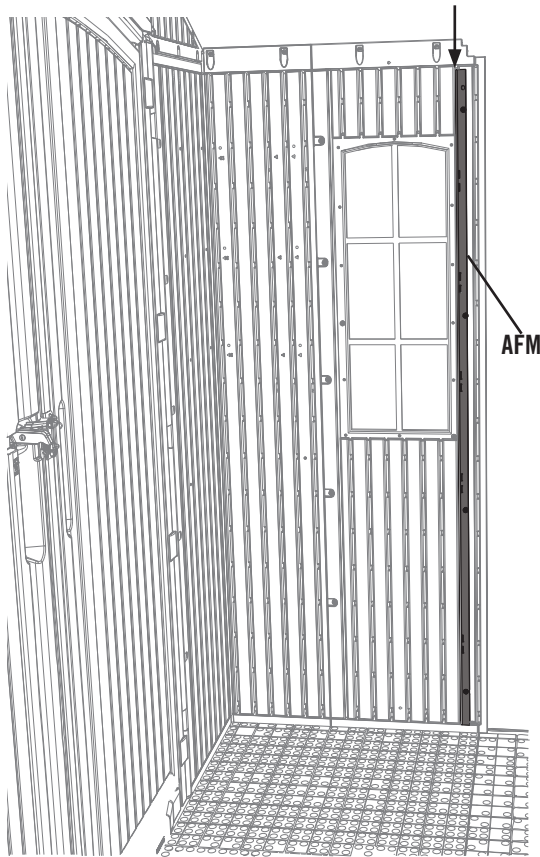

Use 2nd groove from the right

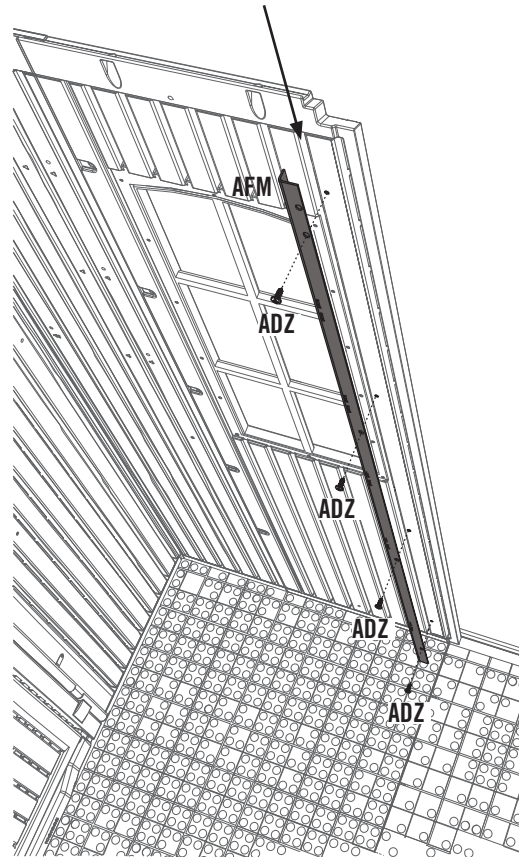

*Note: Use second groove in from edge for Right Half-Window Wall Panel (BDH).*





## TOOLS AND HARDWARE REQUIRED FOR THIS PAGE

SEC. 4

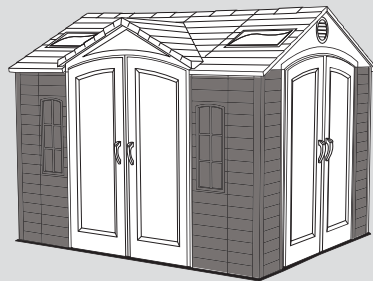

SEC

4.8

Attach a **Wall Support Channel (AFM)** to the Left Half-Window Wall Panel (use the first slot in from the edge, and secure with four (4) **1/4" x 5/8" Pan-Head Screws (ADZ)**).

Use 1st groove from the left

Use 1st groove from the left

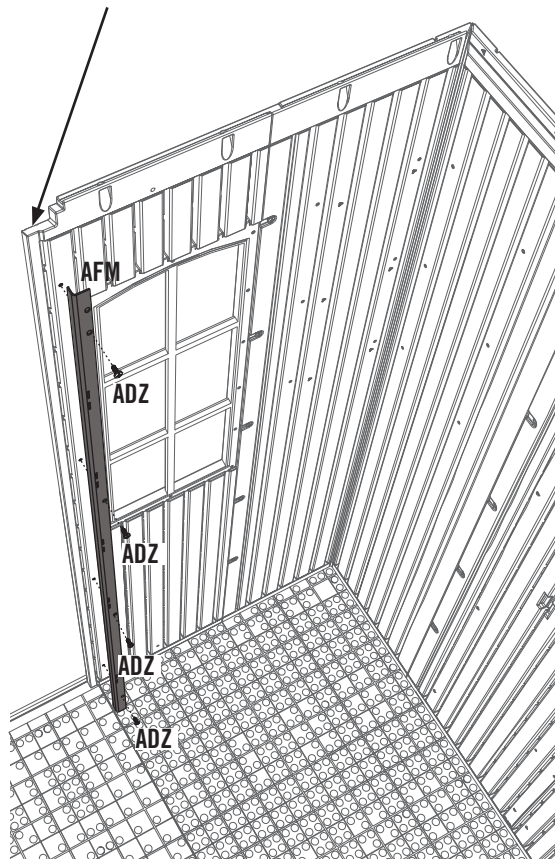
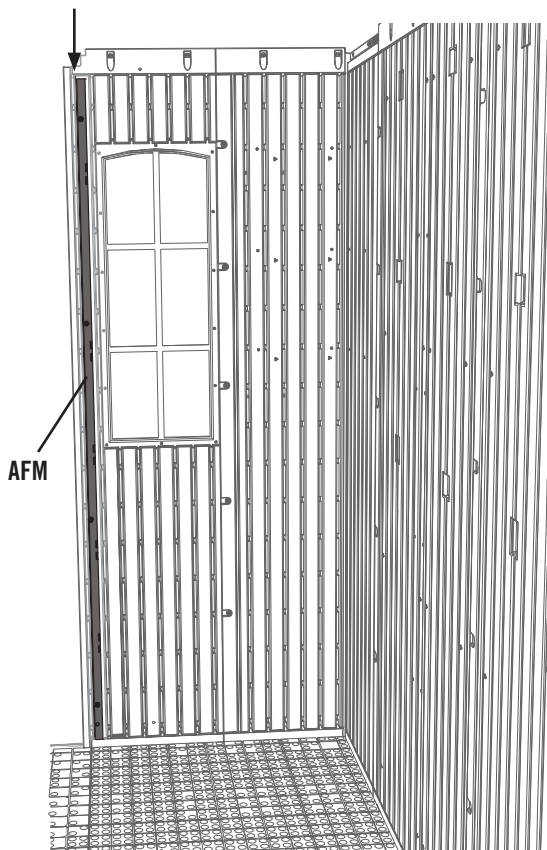

*Note: Use first groove in from edge for Left Half-Window Wall Panel (BDI).*

**SEC 5 DOMED SKYLIGHT ASSEMBLY**

**HARDWARE REQUIRED**

**HARDWARE BAG REQUIRED: BEC (x2)**

Hardware is actual size (\*Unless indicated otherwise)

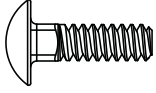

**ACR (x24)**  
#10 x 5/8" Carriage Bolt



**ADK (x24)**  
#10 Cap Nut

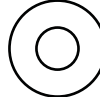

**AEE (x24)**  
#10 Flat Washer



**\*AHI (x2) Butyl Tape**

**PLASTIC PARTS REQUIRED**

Part shown at 4% actual size

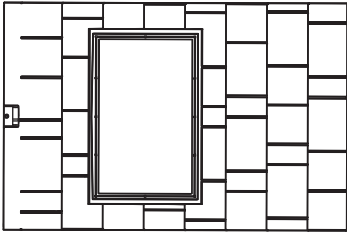

**AHB (x2)**  
Roof Panel for Domed Skylight

Part shown at 8% actual size

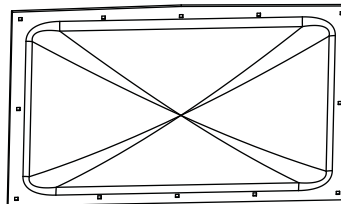

**AGB (x2)**  
Domed Skylight

**TOOLS REQUIRED**



**Plain Screwdriver**



**3/8" Wrench**



**Safety Glasses**



## TOOLS AND HARDWARE REQUIRED FOR THIS PAGE

SEC 5



AHI (x2)  
(Not to scale)

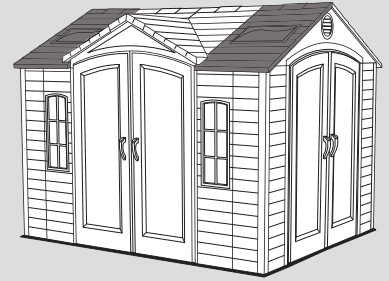

SEC

### DOMED SKYLIGHT ASSEMBLY

5.1

Use a plain screwdriver to gently remove any excess plastic from the twelve holes in the **Roof Panel for Domed Skylight (AHB)**. It's important that the hole stay square; try not to round the corners of the edges of the holes.

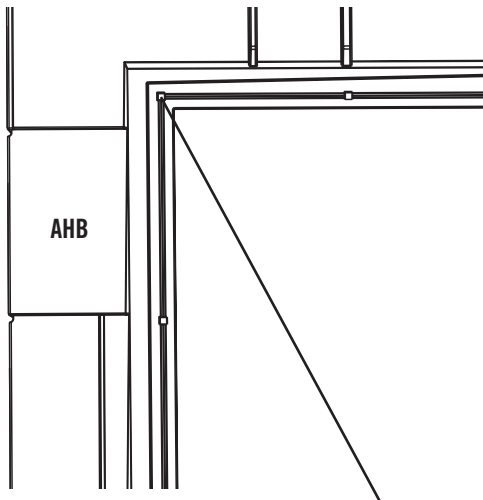

**!** Note: Use a plain screwdriver to remove any excess plastic from all holes in Panel. Ensure the holes remain square.

SEC

5.2

Stick the end of the **Butyl Tape (AHI)** over the groove and top, left hole of the Roof Panel for Domed Skylight as indicated below. Move to the right and over the groove covering all the holes along the top of the opening. Once the top, right corner and hole are covered, cut the Butyl Tape. Run your finger along the paper backing pressing down slightly to remove any gaps or bubbles between the Butyl Tape and the groove. Remove the paper backing from the piece you just applied. Overlap the end of the roll of Butyl Tape with the end you just cut and apply the Butyl Tape over the holes along the groove on the right of the opening. Continue applying the Butyl Tape in this fashion until all holes have been covered and the ends overlap.

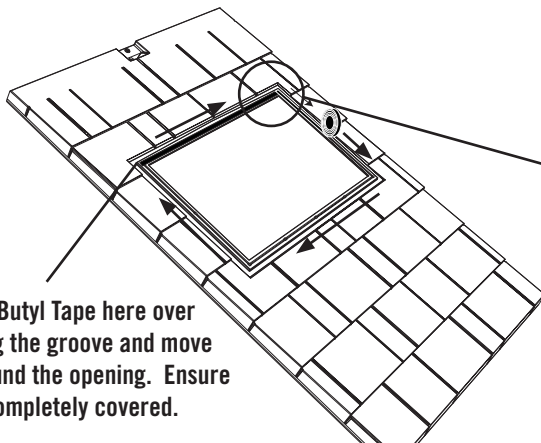

Start applying Butyl Tape here over the holes along the groove and move clockwise around the opening. Ensure all holes are completely covered.

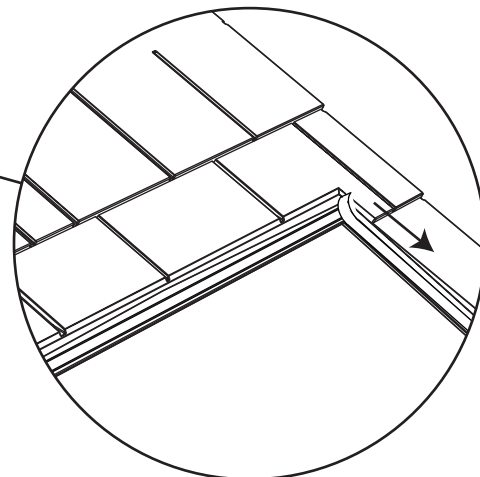

**!** Note: Butyl Tape must overlap at ends and cover all twelve holes.



## TOOLS AND HARDWARE REQUIRED FOR THIS PAGE

SEC. 5



NO HARDWARE REQUIRED FOR THIS PAGE

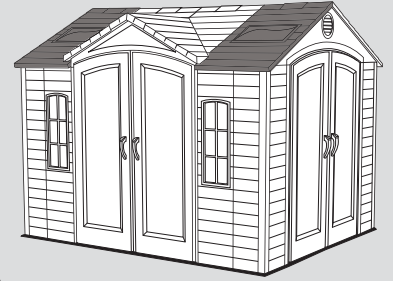

SEC

5.3

Insert a screwdriver through the Butyl Tape and into the twelve holes. This will help you align the holes in the Domed Skylight with those in the Roof Panel for Domed Skylight in the next step.

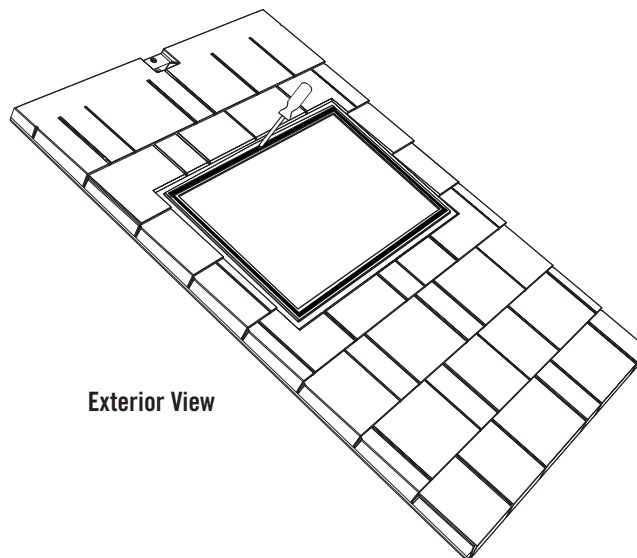

Exterior View

SEC

5.4

Remove the protective plastic film from **both** sides of the **Domed Skylight (AGB)**. Carefully align the holes in the Domed Skylight with those in the Butyl Tape. Set the Domed Skylight over the opening in the Roof Panel for Domed Skylight. Press down and verify there are no gaps or bubbles between the Butyl Tape and the Domed Skylight.

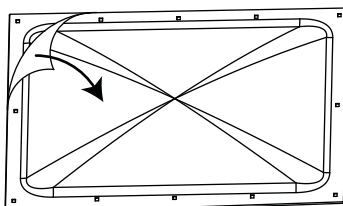

AGB

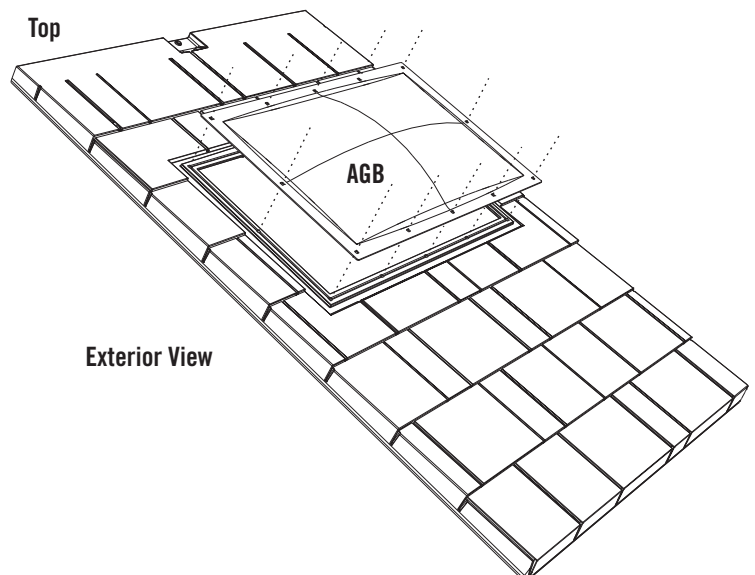

Exterior View



## TOOLS AND HARDWARE REQUIRED FOR THIS PAGE

SEC 5



3/8"

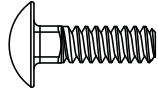

ACR (x24)



ADK (x24)

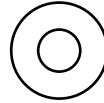

AEE (x24)

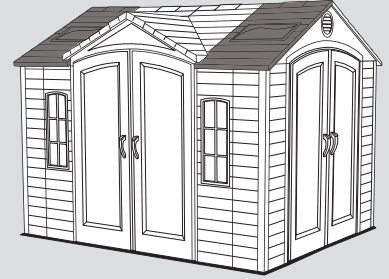

SEC

5.5

Insert one **#10 x 5/8" Carriage Bolt (ACR)** through each hole in the Domed Skylight. Press the Bolt through the Butyl Tape and through the Roof Panel for Domed Skylight. The necks of the Carriage Bolts fit into the square holes in the Domed Skylight.

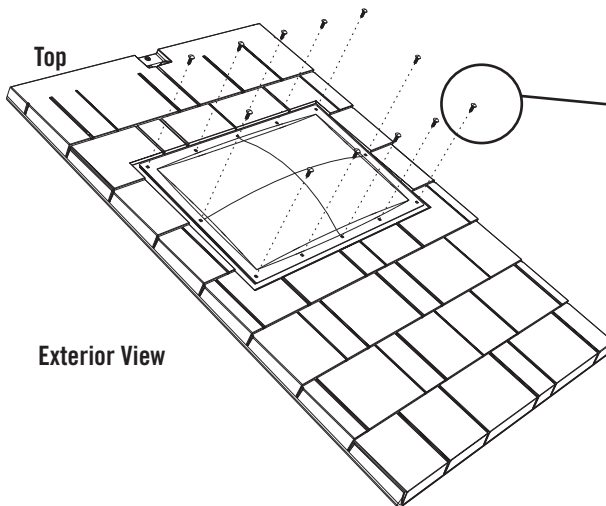

Exterior View

Neck of Carriage Bolt

SEC

5.6

Secure the Domed Skylight to the Roof Panel for Domed Skylight with one (1) **#10 Flat Washer (AEE)** and one (1) **#10 Cap Nut (ADK)** for each Carriage Bolt. Set Skylight/Panel Assembly aside. **Repeat this section for the second Roof Panel for Domed Skylight.**

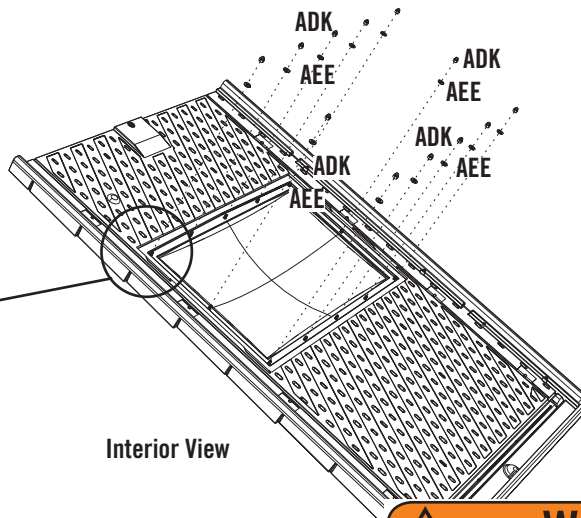
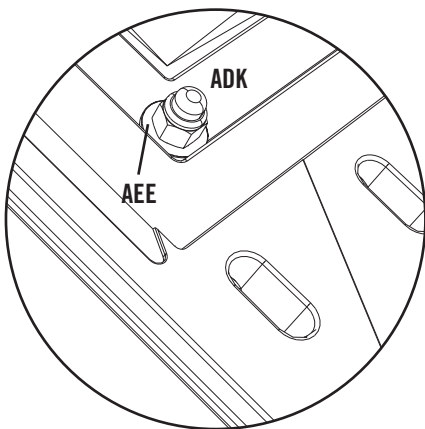

Interior View



### WARNING

Do not overtighten the Cap Nut. If the end of the Bolt breaks through the plastic cap, call our Customer Service Department. Exposed threads on the end of the Bolt may cause serious injuries.

# SEC 6 GABLE ASSEMBLY

## HARDWARE REQUIRED

Hardware shown at actual size

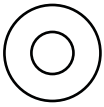

**AEE** (x10)  
#10 x 1/2" Flat Washer

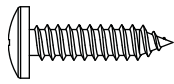

**ADW** (x10)  
#10 x 3/4" Pan-Head Screw

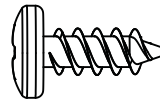

**ADZ** (x8)  
1/4" x 5/8" Pan-Head Screw  
(Only 4 used)

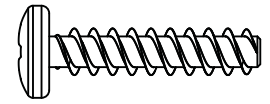

**ADV** (x16)  
1/4" x 1 1/8" Pan-Head Screw  
(Only 10 used)

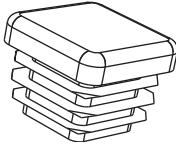

**AHS** (x6)  
End Plug  
(Only 4 used)

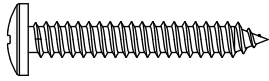

**ACB** (x2)  
#10 x 1 1/4" Pan-Head Screw  
(Not used)

Parts shown at 8% of actual size



**AGP** (x2)  
Louvered Vent

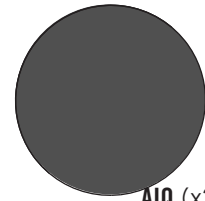

**AIQ** (x2)  
Vent Screen

## METAL PARTS REQUIRED

Parts shown at 8% of actual size



**BDD** (x1) Entry Gable Header Bar

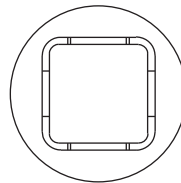

**BFJ** (x1) Side Entry Header Bar

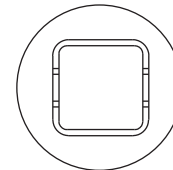

## METAL PARTS KITS REQUIRED: CRF, CRG

## PLASTIC PARTS REQUIRED

Parts shown at 4% of actual size

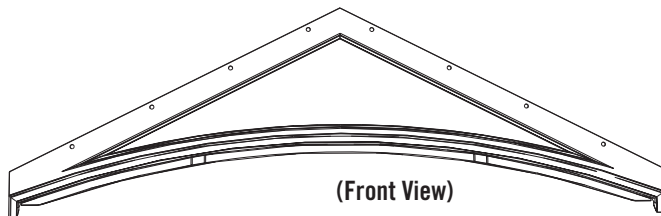

**BDC** (x1)  
Front Entry Gable

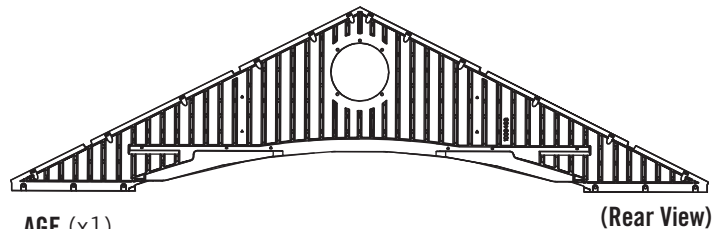

**AGF** (x1)  
Side Entry Gable

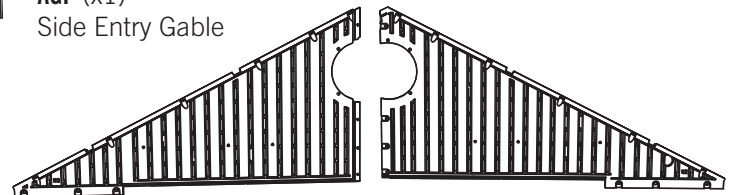

**AGH** (x1)  
Side Gable 1

(Rear View)

**AGI** (x1)  
Side Gable 2

(Rear View)

## TOOLS REQUIRED



Phillips Screwdriver



Safety Glasses



## TOOLS AND HARDWARE REQUIRED FOR THIS PAGE

SEC 6

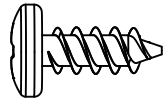

ADZ (x4)

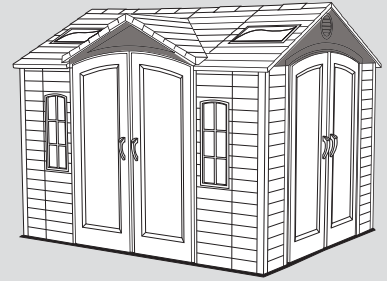

SEC

### SIDE GABLE ASSEMBLY

6.1

Lay the edge of **Side Gable 2 (AGI)** over **Side Gable 1 (AGH)** as shown, and align the four holes.

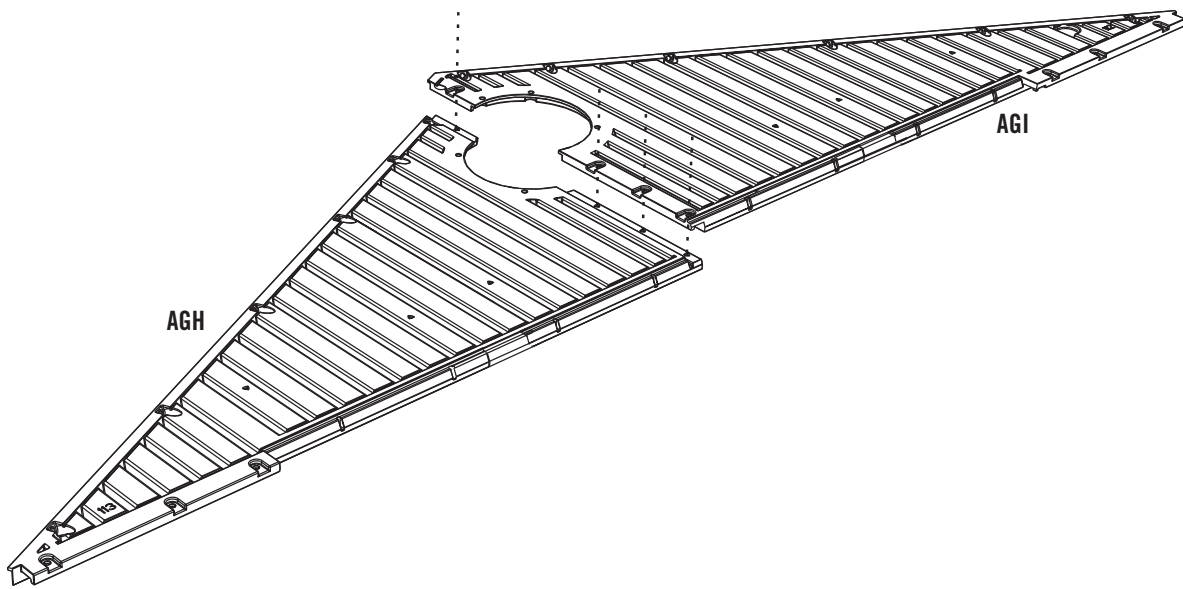

SEC

6.2

Connect Side Gables 1 & 2 together using four (4) 1/4" x 5/8" Pan-Head Screws (ADZ) as shown.

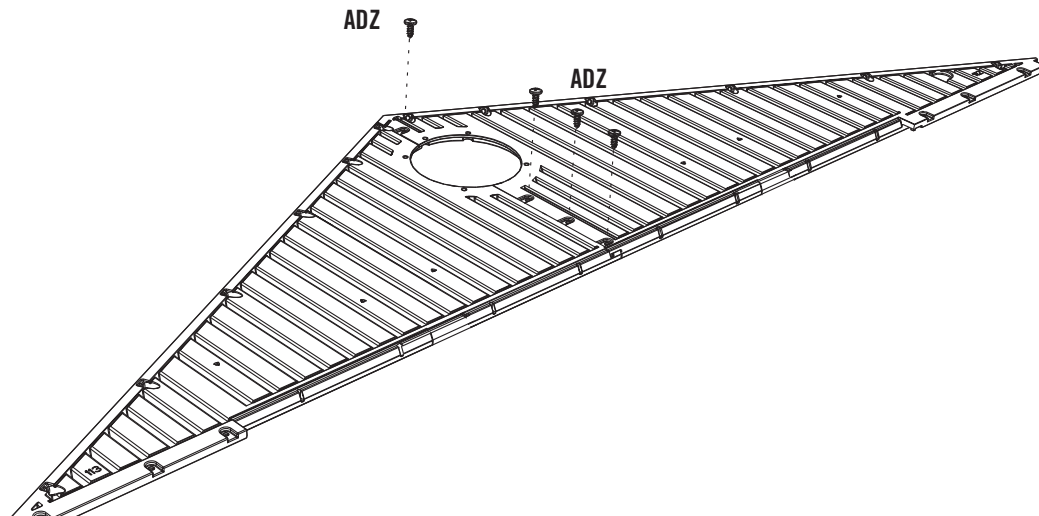

*Note: Only use a hand screwdriver in this step.*



## TOOLS AND HARDWARE REQUIRED FOR THIS PAGE

SEC 6

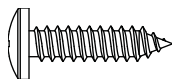

ADW (x5)

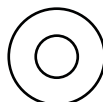

AEE (x5)

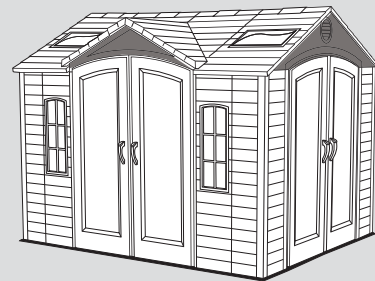

SEC

6.3

Lay Side Gable Assembly flat on the ground over the **Vent Screen (AIQ)** and **Louvered Vent (AGP)**. Align the holes in the Louvered Vent with those in the Side Gable Assembly.

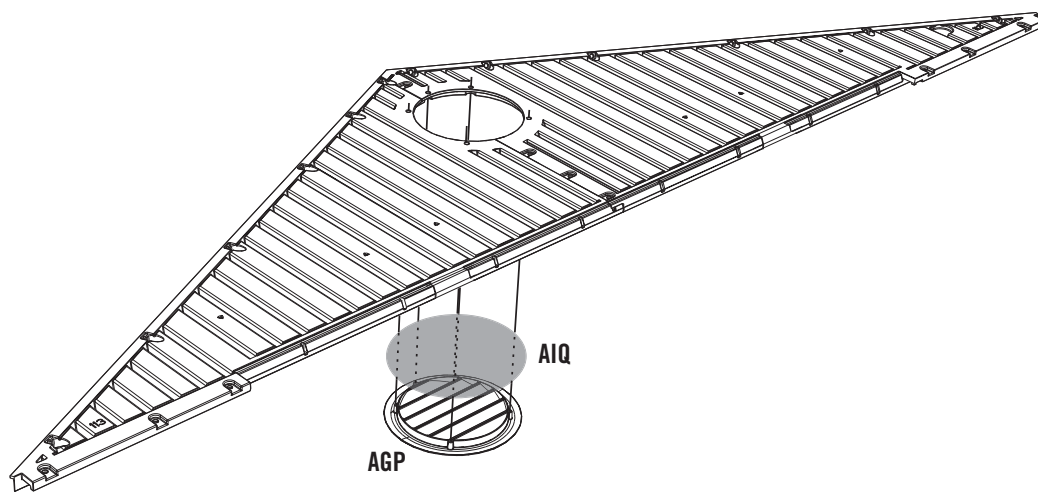

SEC

6.4

After aligning the holes, press down firmly on the Side Gable Assembly when inserting the five (5) **#10 x 3/4" Pan-Head Screws (ADW)** and the five (5) **#10 x 1/2" Flat Washers (AEE)**. Pressing down firmly while inserting the Screws will help prevent the Vent Screen from twisting while inserting the Screws. Set aside.

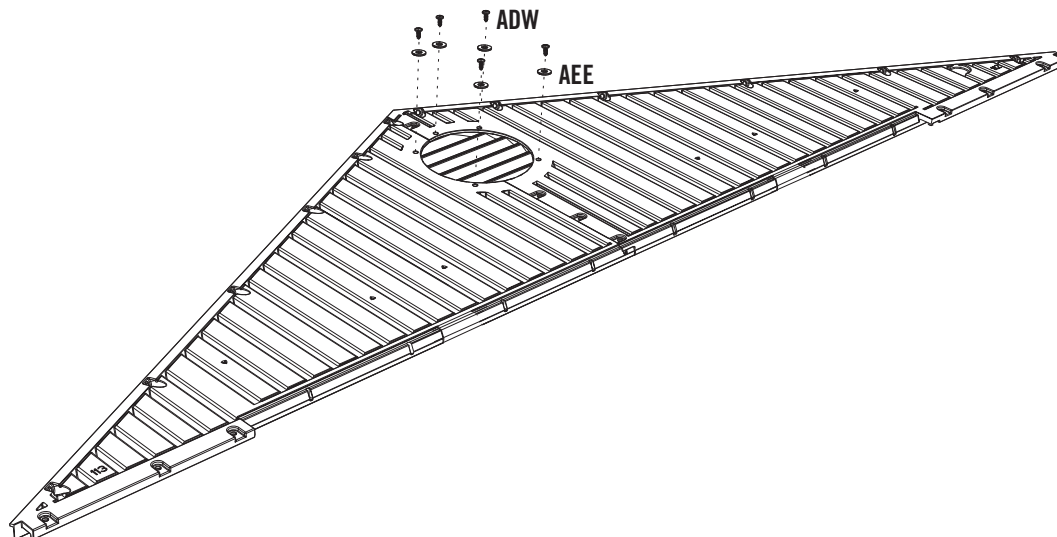

*Note: Only use a hand screwdriver in this step.*



*Note: Press down firmly on the Gable to help prevent the Screen from twisting while inserting the Screws.*





## TOOLS AND HARDWARE REQUIRED FOR THIS PAGE

SEC 6

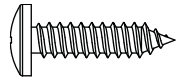

ADW (x5)

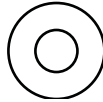

AEE (x5)

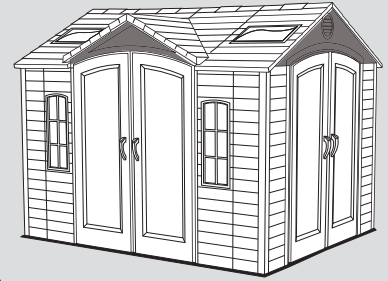

SEC

### SIDE ENTRY GABLE ASSEMBLY

6.5

Lay **Side Entry Gable (AGF)** flat on the ground over the **Vent Screen (AIQ)** and **Louvered Vent (AGP)** as shown. Align the holes in the Louvered Vent with those in the Side Entry Gable.

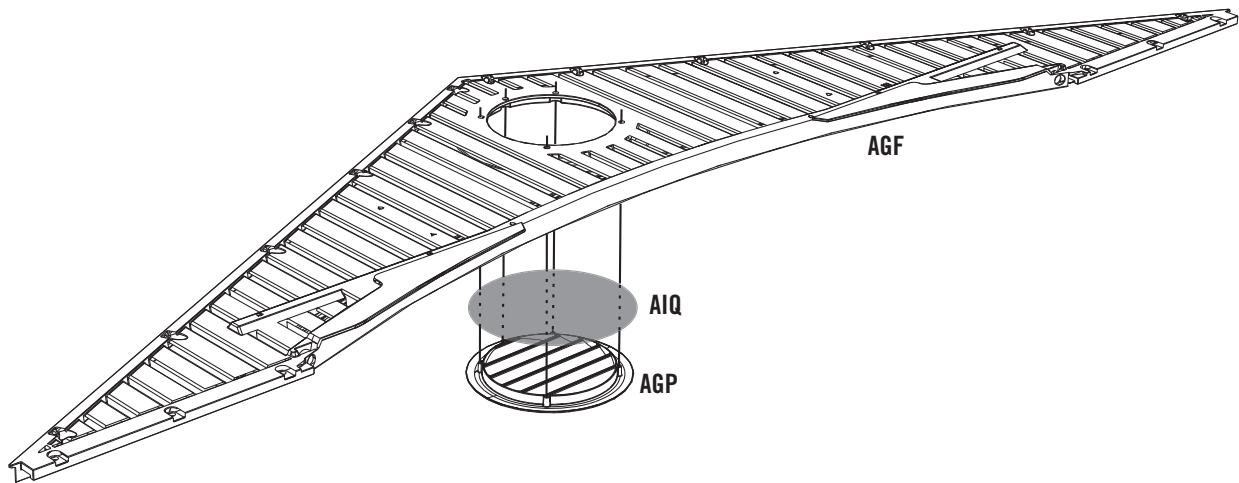

SEC

6.6

After aligning the holes, press down firmly on the Side Entry Gable when inserting the five (5) **#10 x 3/4" Pan-Head Screws (ADW)** and the five (5) **#10 x 1/2" Flat Washers (AEE)**. Pressing down firmly while inserting the Screws will help prevent the Vent Screen from twisting.

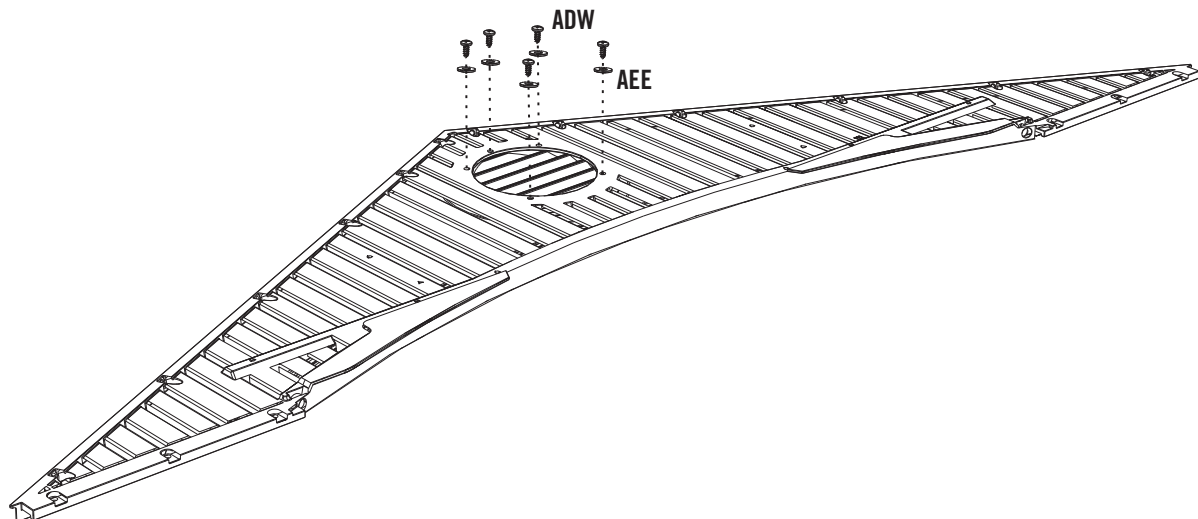

*Note: Only use a hand screwdriver in this step.*



*Note: Press down firmly on the Gable to help prevent the Screen from twisting while inserting the Screws.*



## TOOLS AND HARDWARE REQUIRED FOR THIS PAGE

SEC 6



AHS (x2)



ADV (x6)

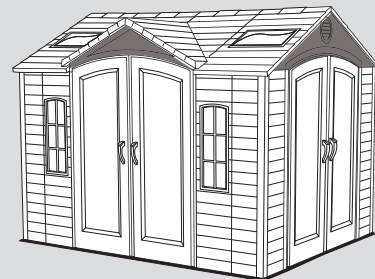

SEC

6.7

Insert an **End Plug (AHS)** into each end of **Side Entry Header Bar (BFJ)**.

The flat holes face away from the Entry Gable.

AHS

BFJ

AHS

The indented, rectangular hole faces downward and towards the right.

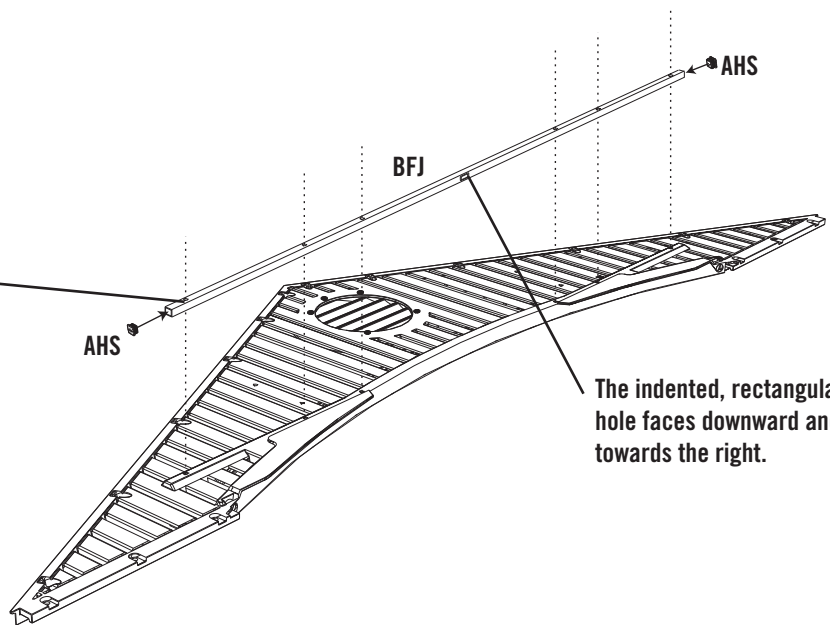

*Note: Only use a hand screwdriver in this step.*

SEC

6.8

Attach the Side Entry Header Bar to the Side Entry Gable Assembly, and secure with six (6) 1/4" x 1 1/8" **Pan-Head Screws (ADV)**. Set aside.

The flat holes face away from the Entry Gable.

ADV

ADV

ADV

The indented, rectangular hole faces downward and towards the right.

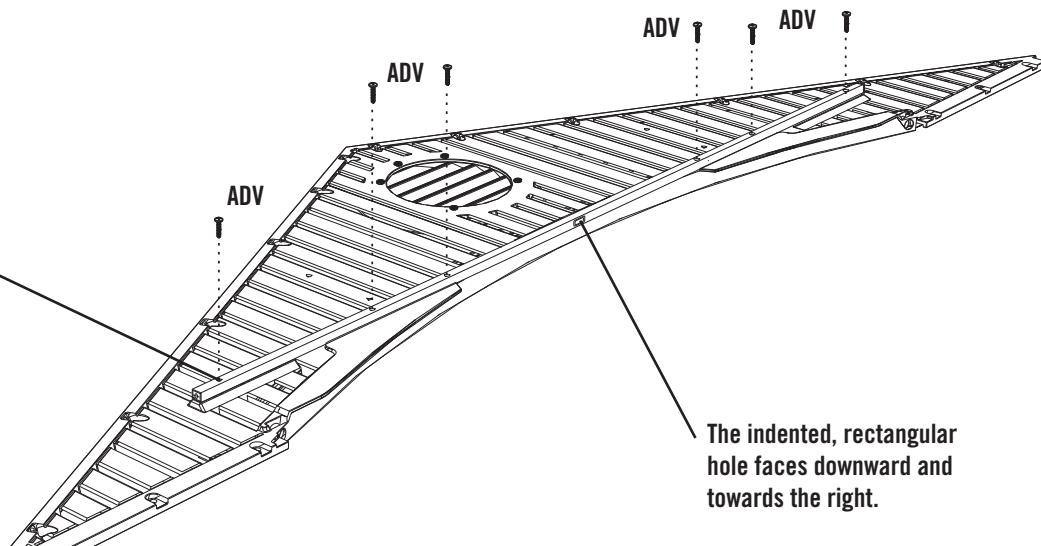

*Note: Only use a hand screwdriver in this step.*



## TOOLS AND HARDWARE REQUIRED FOR THIS PAGE

SEC 6

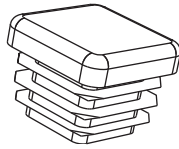

AHS (x2)

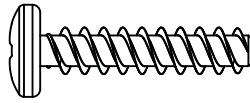

ADV (x4)

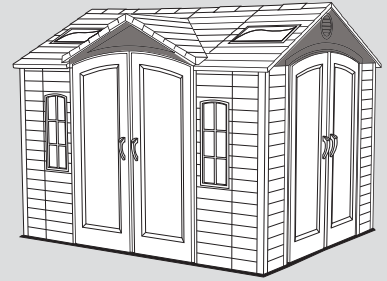

SEC

### FRONT ENTRY GABLE ASSEMBLY

6.9

Insert one **End Plug (AHS)** into each end of the **Entry Gable Header Bar (BDD)** as shown, and align the four holes in the Entry Gable Header Bar with those in the **Front Entry Gable (BDC)**.

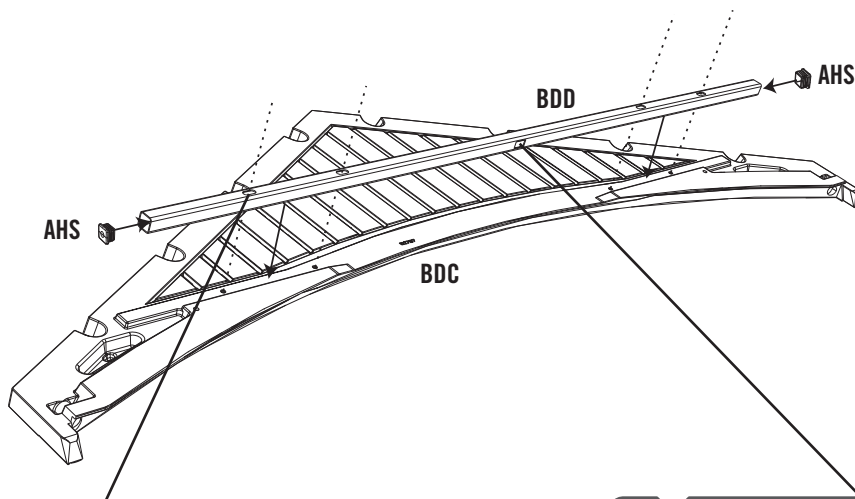

*Note: The indented, oval holes face the Gable.*



*Note: The indented hole faces downward and off center to the right.*

SEC

6.10

Attach the Entry Gable Header Bar to the Front Entry Gable using four (4) **1/4" x 1 1/8" Pan-Head Screws (ADV)**. Set aside.

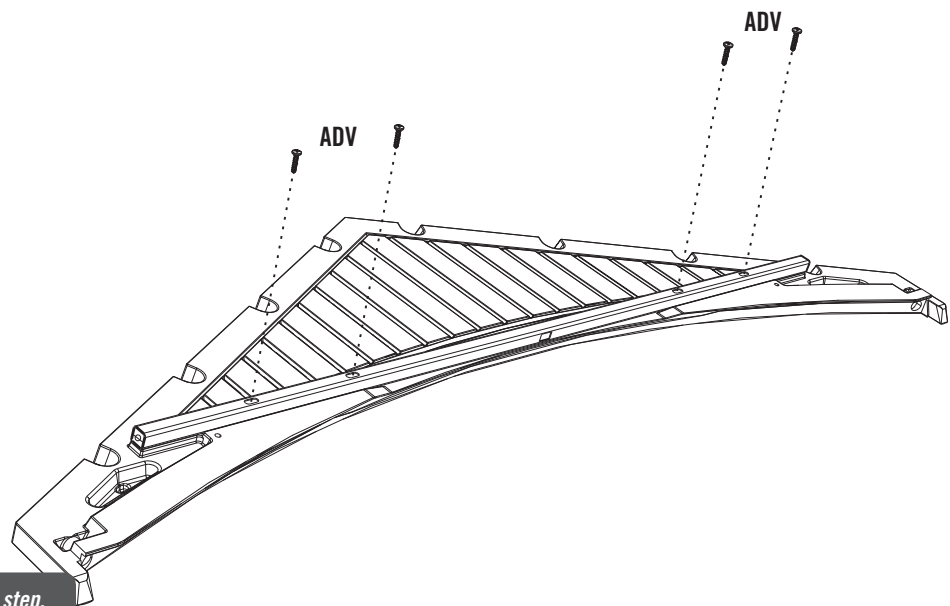

*Note: Only use a hand screwdriver in this step.*

# SEC 7 LEFT DOOR ASSEMBLY

## HARDWARE REQUIRED

Hardware shown at actual size

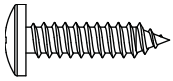

**ADW** (x6)  
#10 x 3/4" Pan-Head Screw

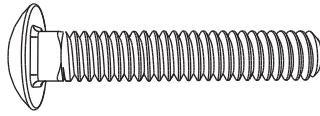

**ABU** (x4)  
1/4" x 1 1/2" Carriage Bolt



**ADJ** (x4)  
1/4" Cap Nut

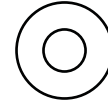

**AEE** (x6)  
#10 Flat Washer

Part shown at 25% of actual size

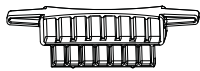

**AHM** (x4)  
Deadbolt Latch

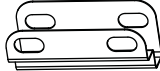

**AIB** (x2)  
Left Door Strike Plate



**AIA** (x2)  
Left Door Lock Bracket

Part shown at 15% of actual size



**AHZ** (x2)  
Left Door Handle

## METAL PARTS REQUIRED

Part shown at 8% of actual size

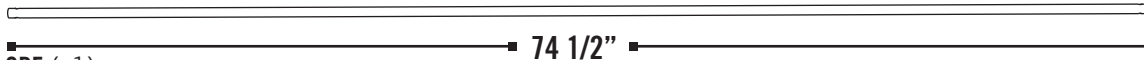

**CRE** (x1)  
Short Door Hinge Tube (For Door with Notch)



**CRD** (x1)  
Long Door Hinge Tube (For Door with No Notch)



**AFC** (x2)  
Door End Channel

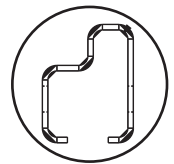

## PLASTIC PARTS REQUIRED

Part shown at 4% of actual size

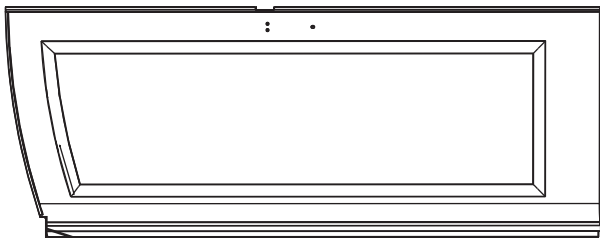

**BDJ** (x1)  
Left Front Door (Notched)

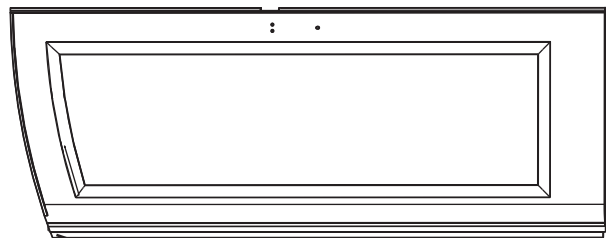

**AGO** (x1)  
Left Side Door (No Notch)

## TOOLS REQUIRED



Phillips Screwdriver



7/16" Wrench



Safety Glasses



## TOOLS AND HARDWARE REQUIRED FOR THIS PAGE

SEC 7

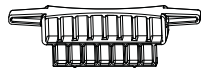

AHM (x4)

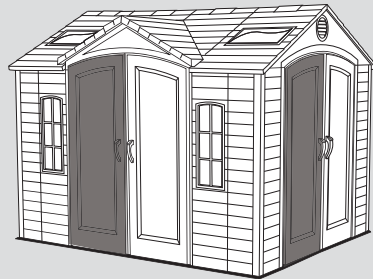

SEC

### LEFT DOOR ASSEMBLY

7.1

Rest the **Left Shed Door (Notched) (BDJ)** with front side down. Slide a **Short Door Hinge Tube (CRE)** through the hole in the Door as shown.

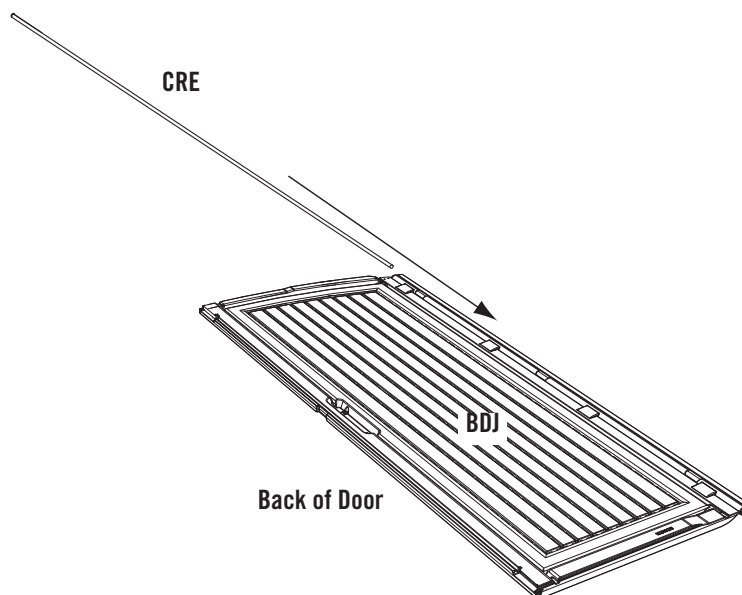

SEC

7.2

Position the **Deadbolt Latches (AHM)** in slots at the top and bottom of the Door, then slide the **Door End Channel (AFC)** onto the Door as shown.

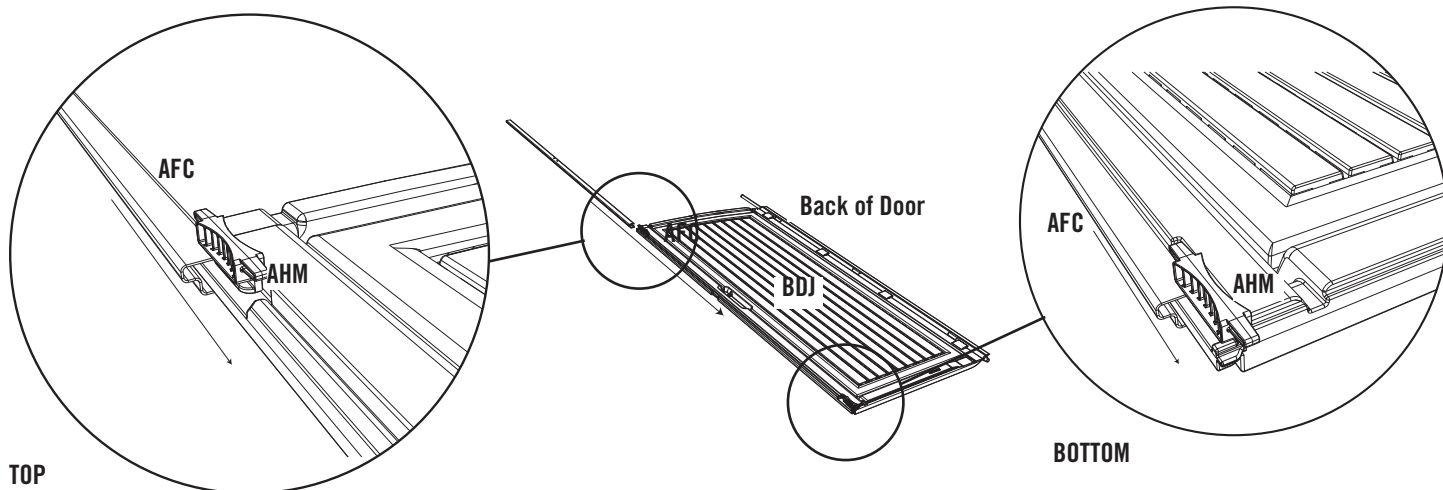

TOP

BOTTOM



*Note: The Door End Channel fits onto Door with the flat side up (facing the Deadbolt Latches).*



## TOOLS AND HARDWARE REQUIRED FOR THIS PAGE

SEC. 7



7/16"

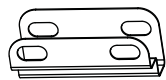

AIB (x2)

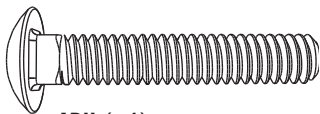

ABU (x4)



ADJ (x4)



AIA (x2)

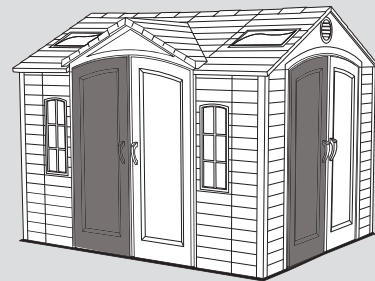

SEC

7.3

Slip the **Left Door Strike Plate (AIB)** over the Left Shed Door and align the holes.

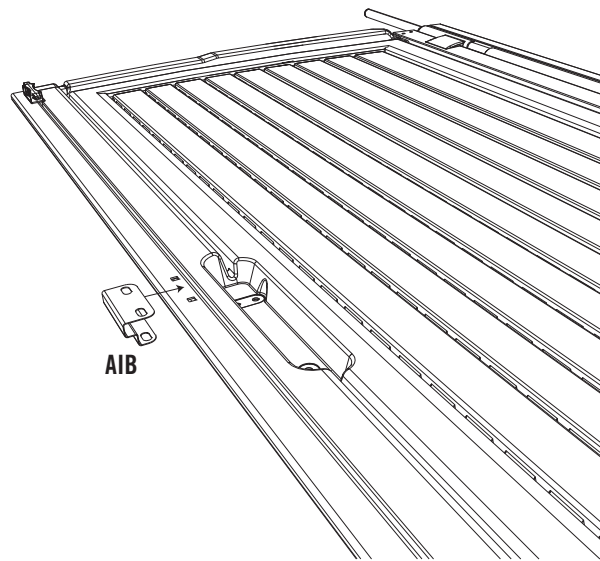

*Note: You may need to nudge the Door End Channel to make these holes line up with the gap in the Door.*

SEC

7.4

Attach the **Left Door Lock Bracket (AIA)** to the Left Door Strike Plate with two (2) 1/4" x 1 1/2" **Carriage Bolts (ABU)** and two (2) 1/4" **Cap Nuts (ADJ)**.

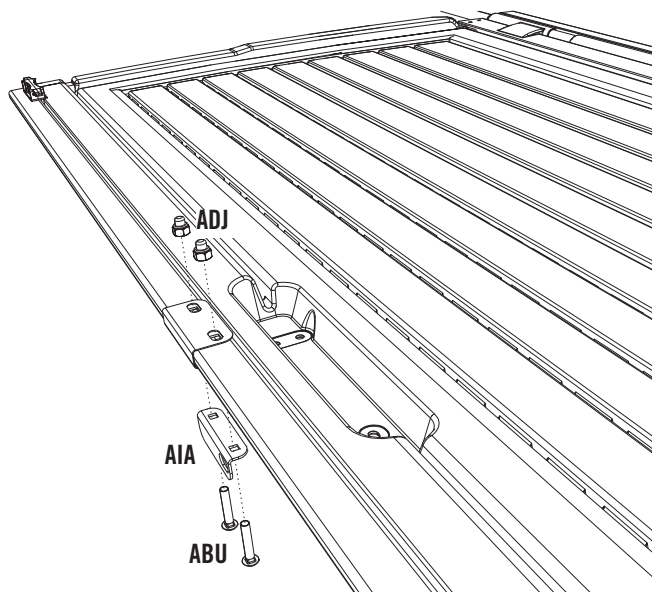

### WARNING

Do not overtighten the Cap Nut. If the end of the Bolt breaks through the plastic cap, call our Customer Service Department. Exposed threads on the end of the Bolt may cause serious injuries.



## TOOLS AND HARDWARE REQUIRED FOR THIS PAGE

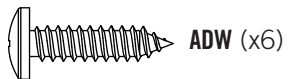

SEC 7

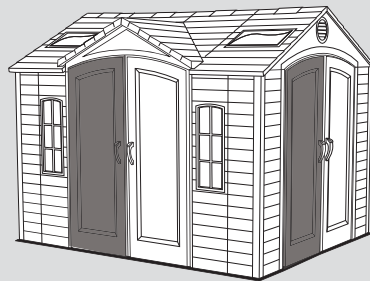

SEC

7.5

Attach the **Left Door Handle (AHZ)** to the Door using three **#10 Flat Washers (AEE)** and three **#10 x 3/4" Pan-Head Screws (ADW)**. Repeat this section for the **Left Side Door (No Notch) (AGO)** and a **Long Door Hinge Tube (CRD)**.

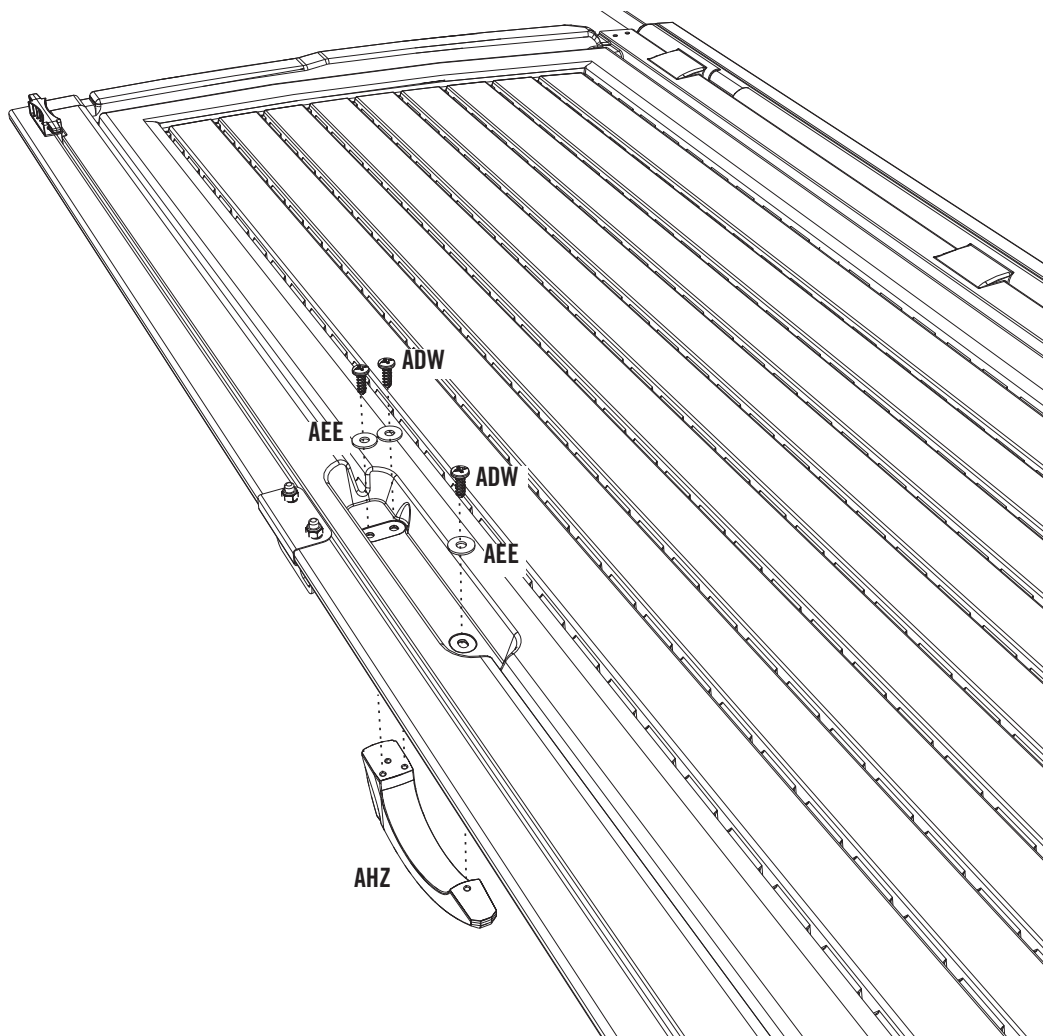

**SEC 8 RIGHT DOOR ASSEMBLY**

**HARDWARE REQUIRED**

Hardware shown at actual size

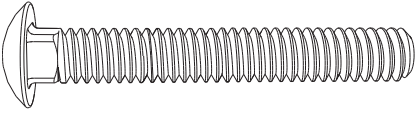

**ACI (x4)**  
1/4" x 2" Carriage Bolt

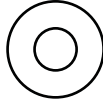

**AEE (x6)**  
#10 Flat Washer



**ADB (x4)**  
3/8" x 1/2" Steel Spacer

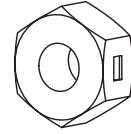

**AAB (x4)**  
1/4" Centerlock Nut

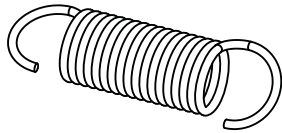

**AHY (x2)**  
Latch Spring

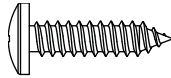

**ADW (x8)**  
#10 x 3/4" Pan-Head Screw

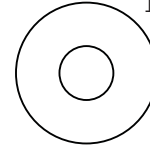

**AEB (x4)**  
1/4" Flat Washer

Part shown at 25% of actual size

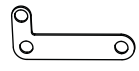

**AHX (x2)**  
Latch Cover Plate

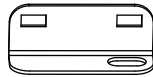

**AIL (x2)**  
Right Door Lock Bracket

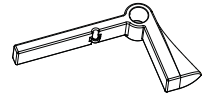

**AHV (x2)**  
Door Latch

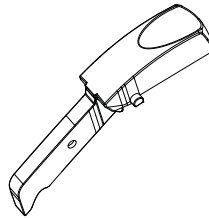

**AIO (x2)**  
Thumb Lever

Part shown at 15% of actual size



**AIK (x2)**  
Right Door Handle

Part shown at 50% of actual size

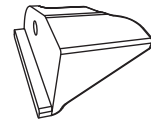

**AHW (x2)**  
Thumb Lever Extension

**METAL PARTS REQUIRED**

Part shown at 8% of actual size

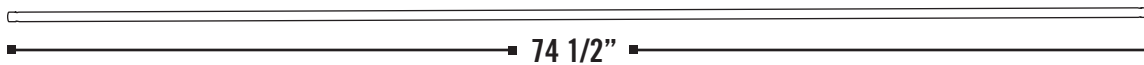

**CRE (x1)**  
Short Door Hinge Tube (For Door with Notch)



**CRD (x1)**  
Long Door Hinge Tube (For Door with No Notch)

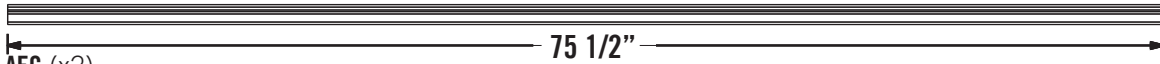

**AFC (x2)**  
Door End Channel

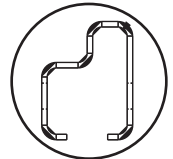

**PLASTIC PARTS REQUIRED**

Part shown at 4% of actual size

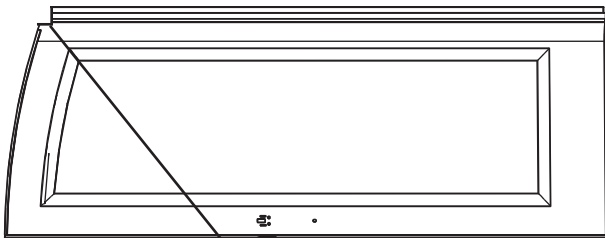

**BDK (x1)**  
Right Front Door (Notched)

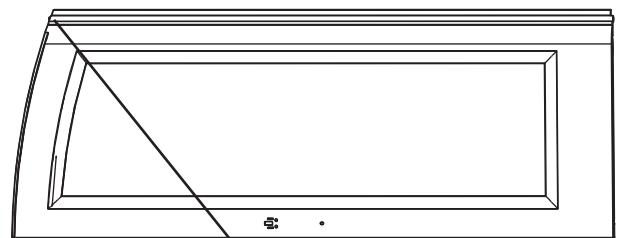

**AGZ (x1)**  
Right Side Door (No Notch)

**TOOLS REQUIRED**



Phillips Screwdriver



7/16" Wrench

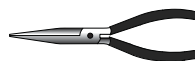

Needle-Nosed Pliers



Safety Glasses





## TOOLS AND HARDWARE REQUIRED FOR THIS PAGE

SEC 8



NO HARDWARE REQUIRED FOR THIS PAGE

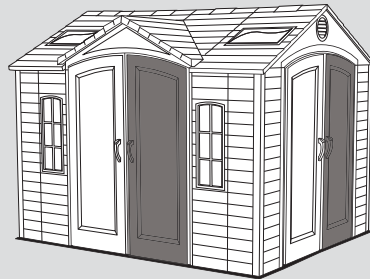

SEC

### RIGHT FRONT DOOR ASSEMBLY

8.1

Rest the **Right Shed Door (Notched) (BDK)** with front side down. Slide a **Short Door Hinge Tube (CRE)** through the hole in the Door as shown.

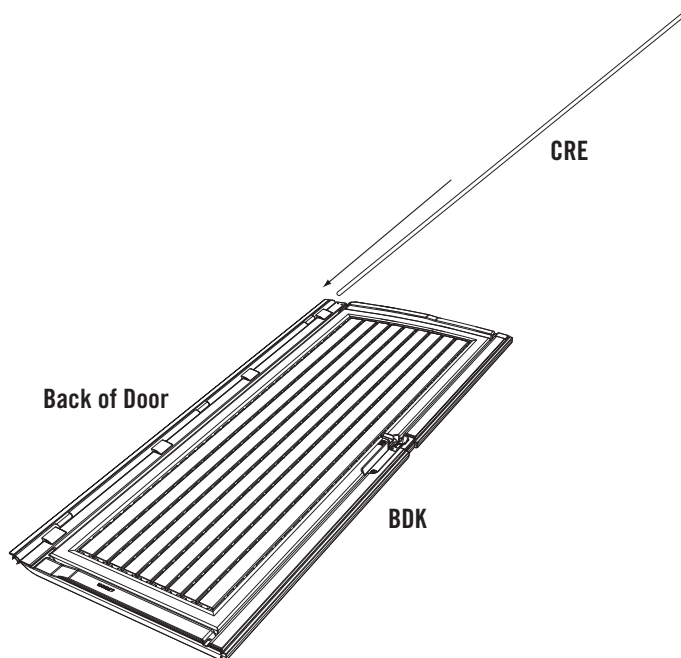

SEC

8.2

Slide the **Door End Channel (AFC)** onto the Door as shown.

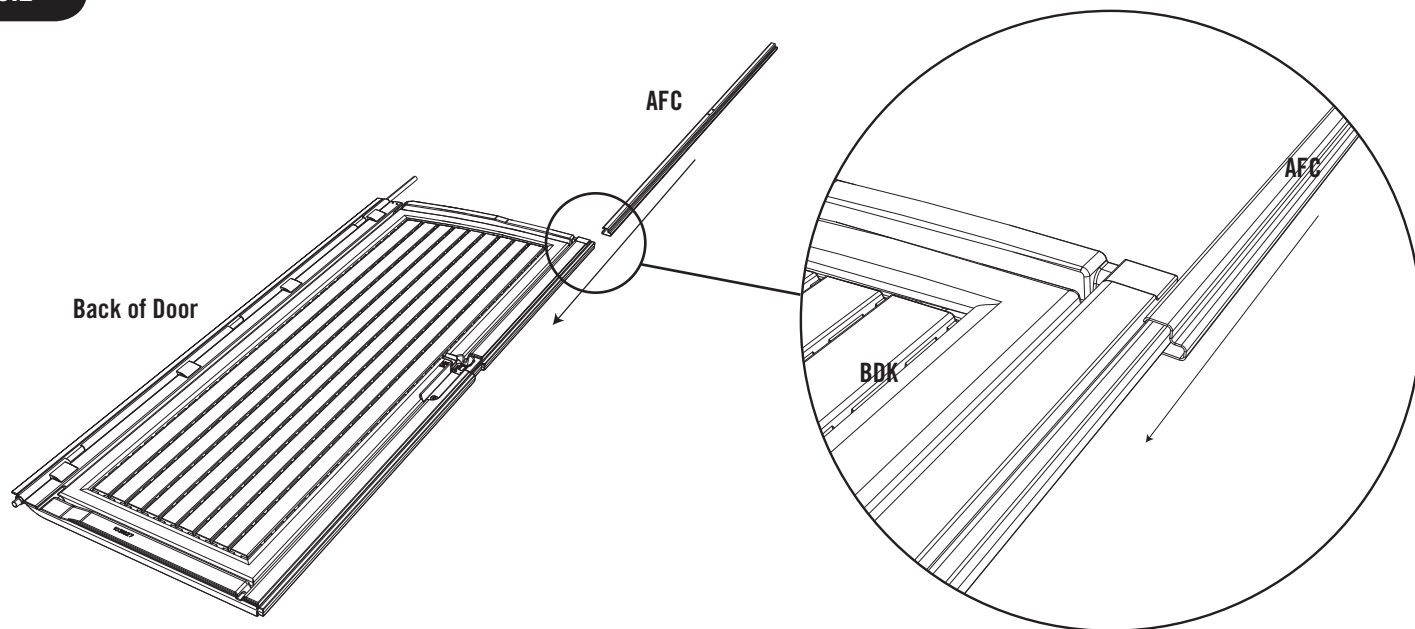



## TOOLS AND HARDWARE REQUIRED FOR THIS PAGE

SEC 8



NO HARDWARE REQUIRED FOR THIS PAGE

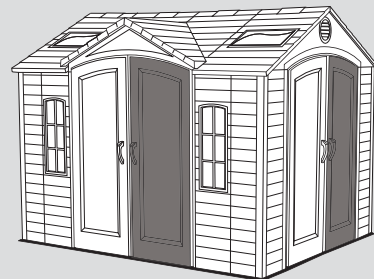

SEC

8.3

Fit knobs of the **Thumb Lever (A10)** into the grooves of the **Right Door Handle (AIK)**.

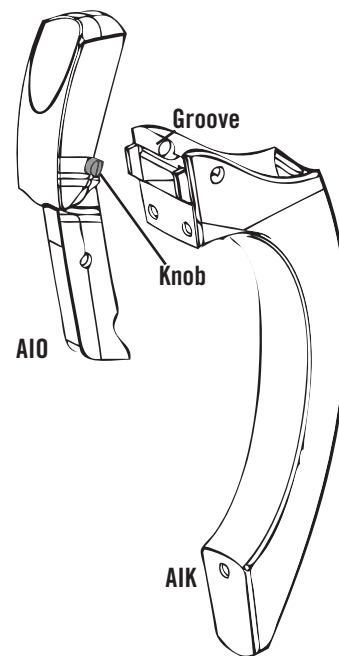

SEC

8.4

Rotate the Thumb Lever into the Right Door Handle. Slide forward until the knobs fit into the holes in the Handle.

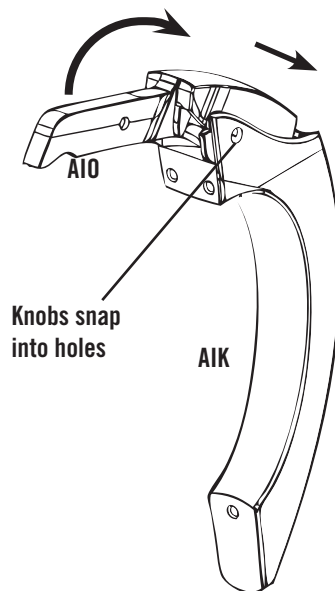



# TOOLS AND HARDWARE REQUIRED FOR THIS PAGE

SEC 8

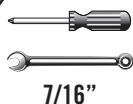

7/16"

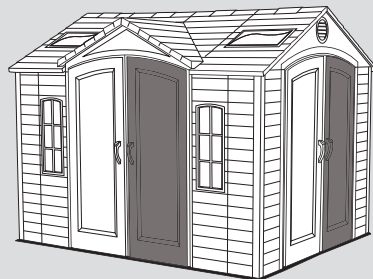
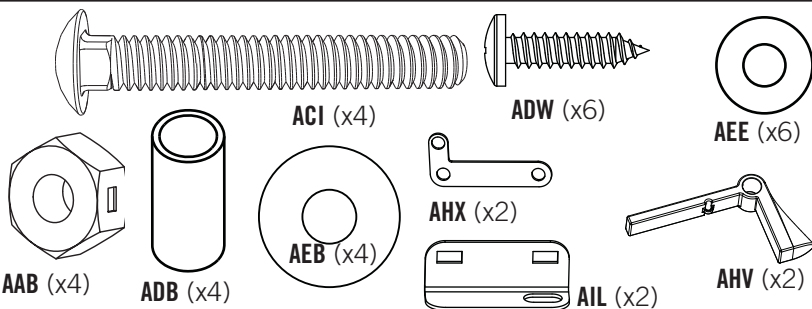

## SEC

8.5

Attach the Right Handle Assembly to the Door using three (3) #10 Flat Washers (AEE) and three (3) #10 x 3/4" Pan-Head Screws (ADW).

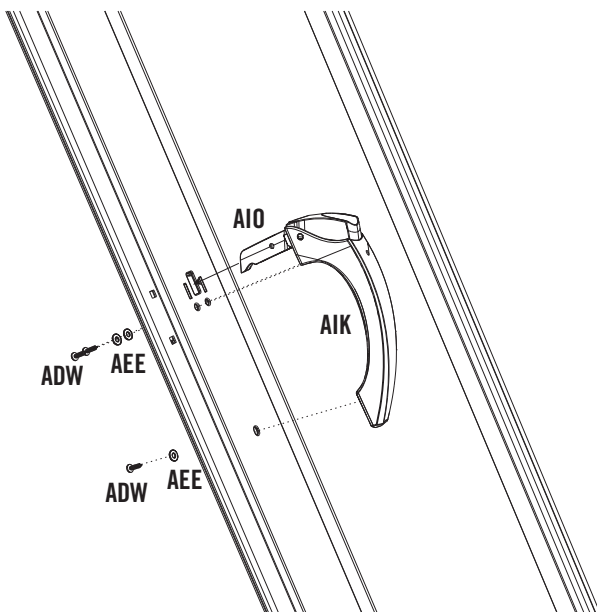

**CAUTION**  
Do not overtighten. Overtightening may damage parts and void warranty.

## SEC

8.6

Install Handle Latch assembly onto the Right Door using the required hardware.

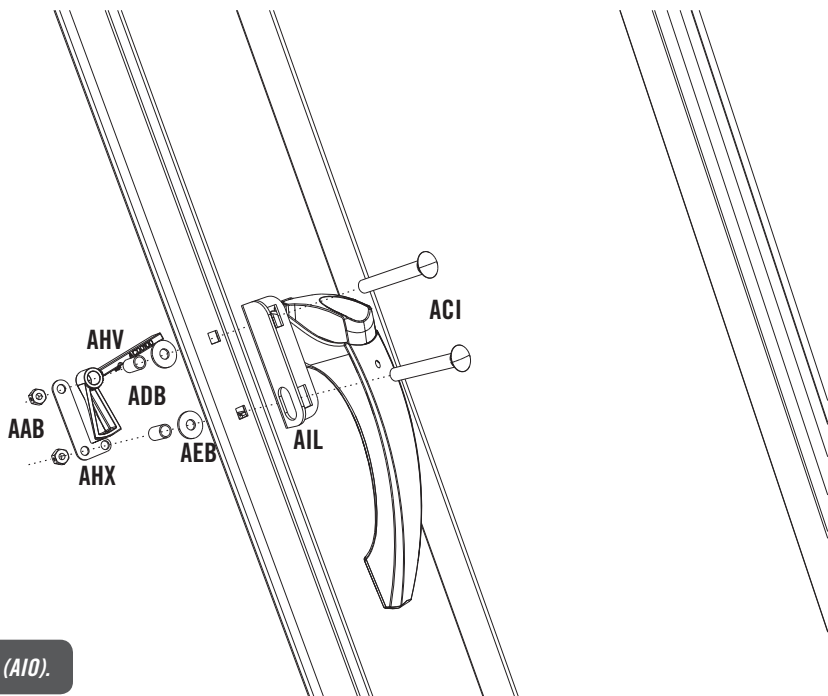
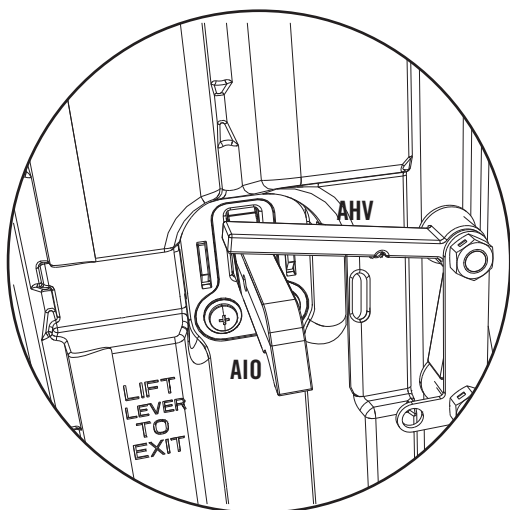

**!** Note: The Door Latch (AHV) goes on top of the Thumb Lever (AIO).



## TOOLS AND HARDWARE REQUIRED FOR THIS PAGE

SEC 8

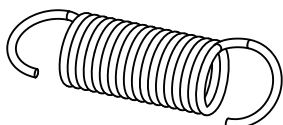

AHY (x2)

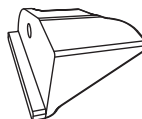

AHX (x2)



ADW (x2)

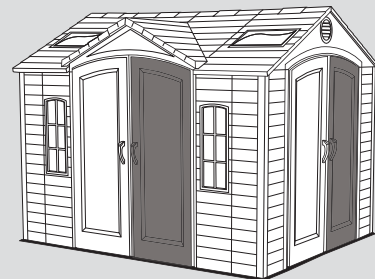

SEC

8.7

Line up the hole in the **Thumb Lever Extension (AHW)** with the hole in the Thumb Lever and **#10 x 3/4" Pan-Head Screw (ADW)** into place.



*Note: The Spring is not shown in this illustration in order to better show the correct placement of the Latch Block.*

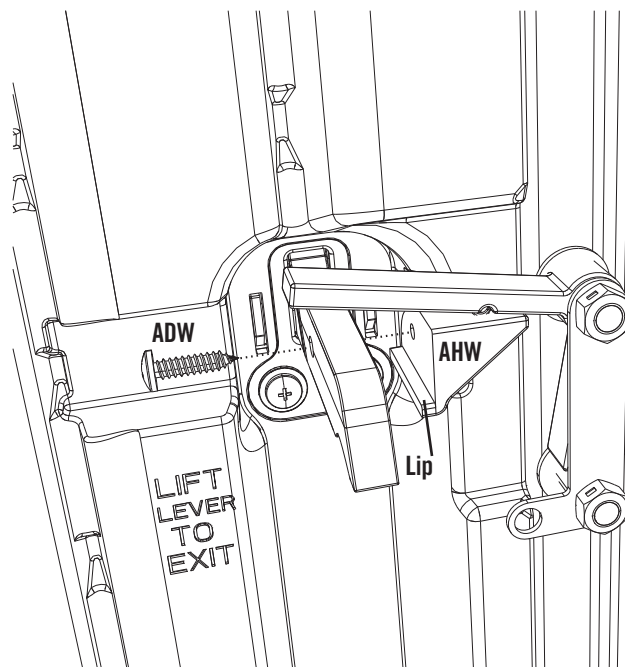

*Note: The lip of the Latch Block (AHW) fits under the Thumb Lever (AIO).*

SEC

8.8

Attach **Latch Spring (AHY)** to the **Door Latch (AHV)** and the **Latch Cover Plate (AHX)**. Set the Door aside. **Repeat this section for the Right Side Door (No Notch) (AGZ) and the Long Door Hinge Tube (CRD).**

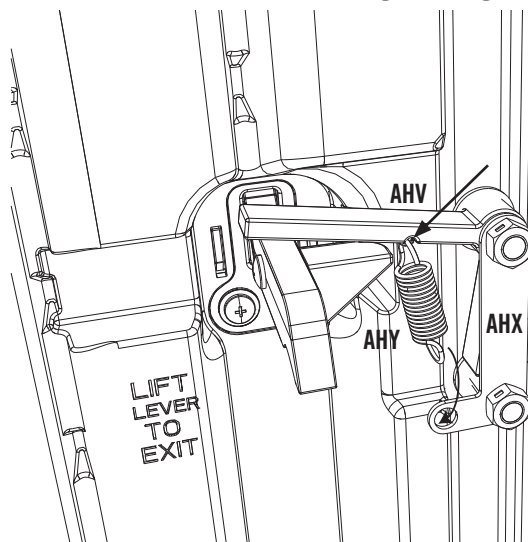

*Note: Use pliers to pull spring down and hook into bottom hole.*



### WARNING

While performing this step, each person should use protective eye glasses to help prevent serious eye injury.

**SEC 9 GABLE, TRUSS, DOOR, & ROOF INSTALLATION**

**HARDWARE REQUIRED**

Hardware shown at actual size (\*Unless noted otherwise)

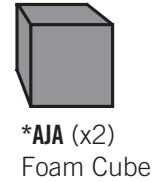
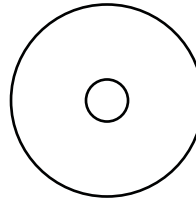
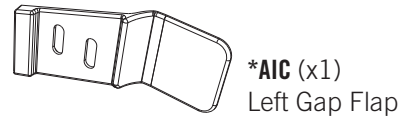
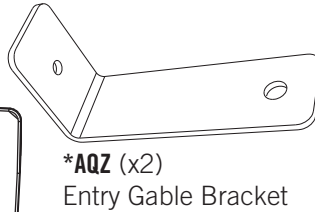
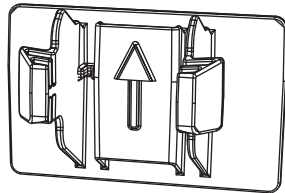
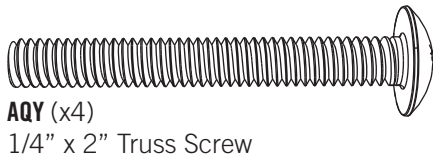

**HARDWARE BAG REQUIRED: BOE**

**METAL PARTS REQUIRED**

Parts shown at 8% of actual size (Unless noted otherwise)



**AFL (x8)**  
Roof Support Strip

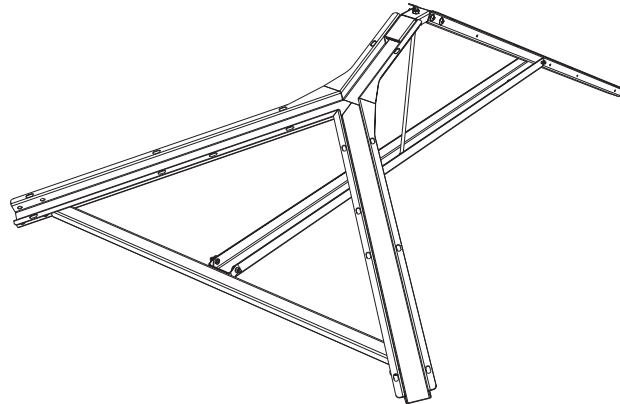
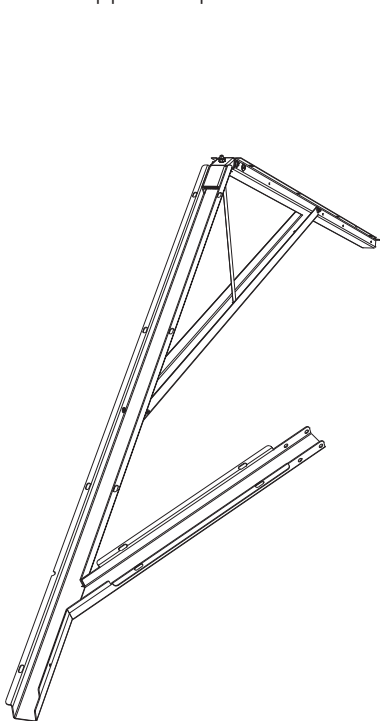

**Center Truss Assembly (x1)**  
(Not shown any scale)

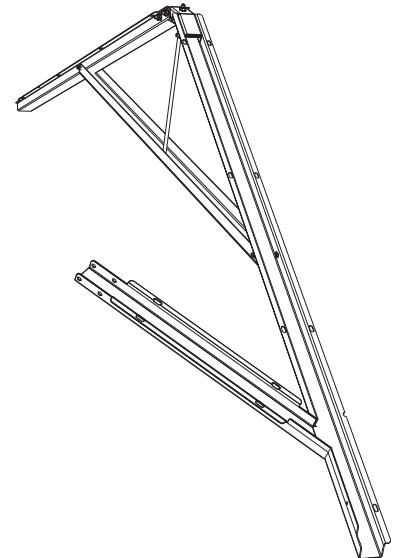

**Right Angled Truss Assembly (x1)**  
(Not shown any scale)

**PARTS KITS REQUIRED: CGU, CKQ**

**PLASTIC PARTS REQUIRED**

**PARTS KIT REQUIRED: CGU**

Parts shown at 4% of actual size

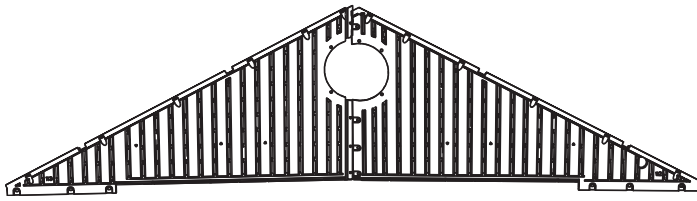

**Side Gable Assembly (x1)**

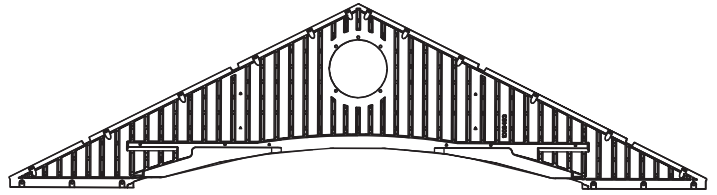

**Side Entry Gable Assembly (x1)**

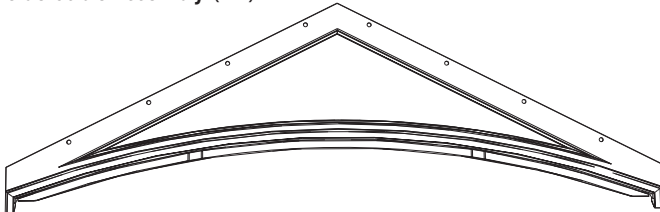

**Entry Gable Assembly (x1)**

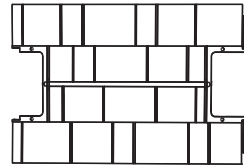

**AFY (x3)**  
Center Roof Cap

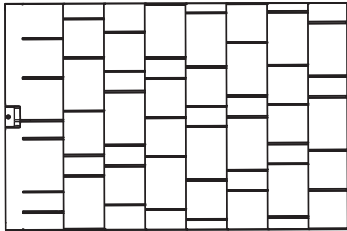

**AGQ (x4)**  
Roof Panel

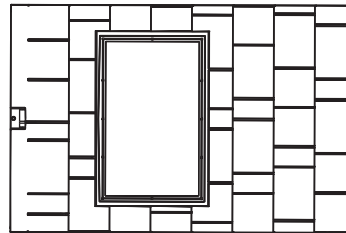

**Roof Panel for Skylight Assembly (x2)**

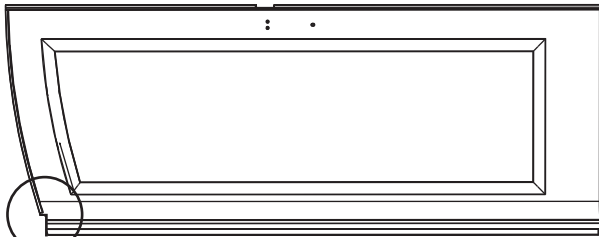

**BDJ (x1)**  
Left Front Door Assembly (Notched)

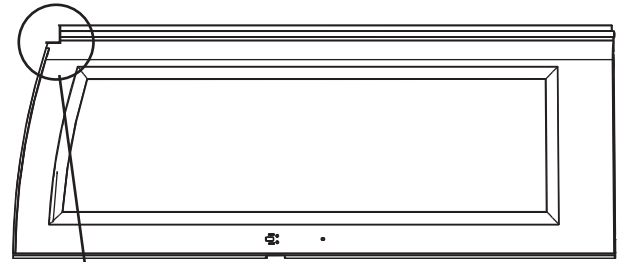

**BDK (x1)**  
Right Front Door Assembly (Notched)

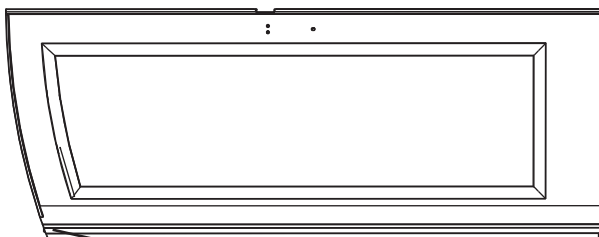
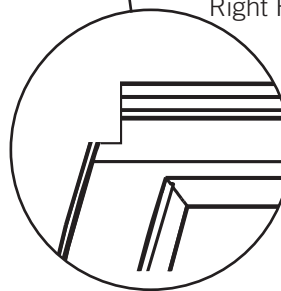
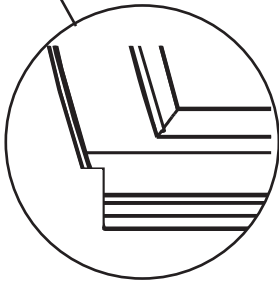

**AGO (x1)**  
Left Side Door Assembly (No Notch)

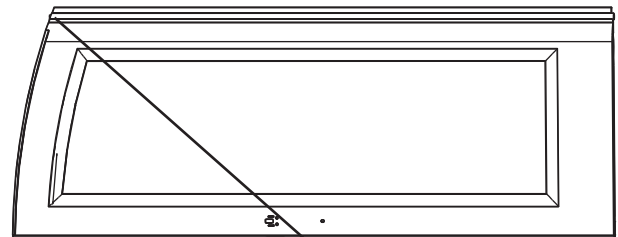

**AGZ (x1)**  
Right Side Door Assembly (No Notch)

**PLASTIC PARTS REQUIRED (CONT.)**

**PARTS KIT REQUIRED: CGU**

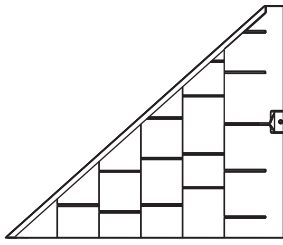

**BDT (x1)**  
Upper Left, Front Gable Roof Panel

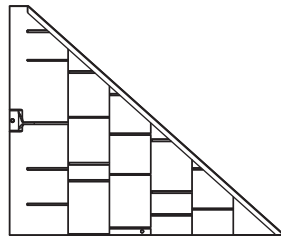

**BDU (x1)**  
Upper Right, Front Gable Roof Panel

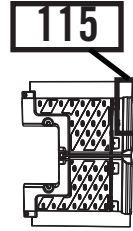

**AGG (x1)**  
Left End Roof Cap

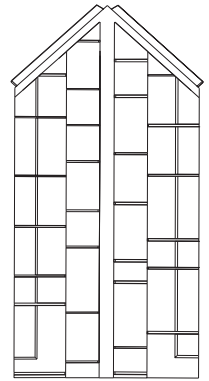

**BDW (x1)**  
Entry Gable Roof Cap

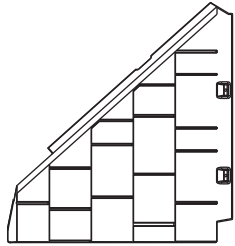

**BDR (x1)**  
Lower Left, Front Gable Roof Panel

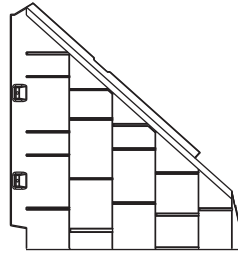

**BDS (x1)**  
Lower Right, Front Gable Roof Panel

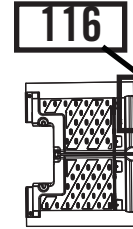

**AFW (x1)**  
Right End Roof Cap

Part shown at 8%  
of actual size

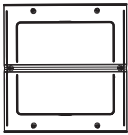

**AHC (x4)**  
Skylight

**TOOLS REQUIRED**

**HARDWARE BAG REQUIRED: BOE**



**Phillips Screwdriver**

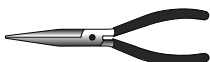

**Needle-Nosed Pliers**



**Drill**



**ARA (x1) 1/8" Drill Bit (Included)**



**7/16" Wrench**



**Safety Glasses**



## TOOLS AND HARDWARE REQUIRED FOR THIS PAGE

SEC 9



AHP (x2)

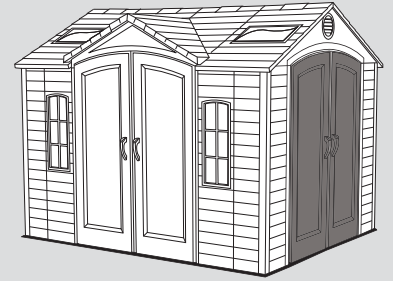

### SEC

#### SIDE DOOR INSTALLATION

##### 9.1

Insert the bottom of the Door Hinge Tube on the **Left Side Door Assembly (No Notch) (AGO)** into the Door Hinge Bushing on the side of your shed.

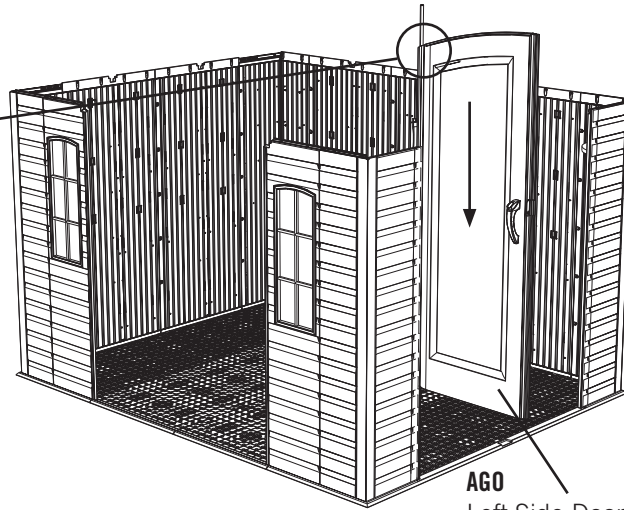
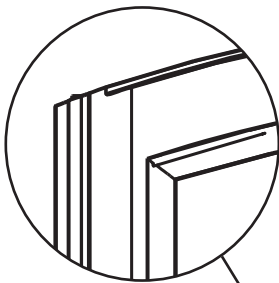

AGO  
Left Side Door Assembly (No Notch)



*Note: The Left & Right Side Doors assembled here have no notches at the top corners.*

### SEC

##### 9.2

Insert a **Cotter Pin (AHP)** through the Bushing and Door Hinge. Use a pair of pliers to bend the ends of the Cotter Pins outward. **Repeat steps 9.1 & 9.2 for the Right Side Door Assembly (No Notch) (AGZ).**

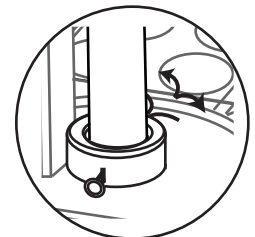
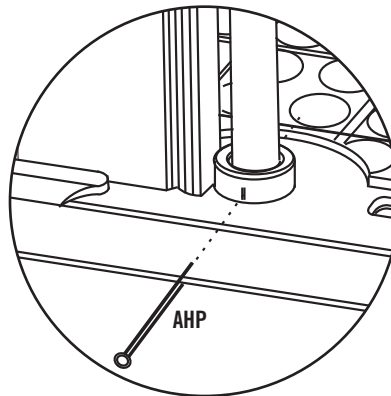
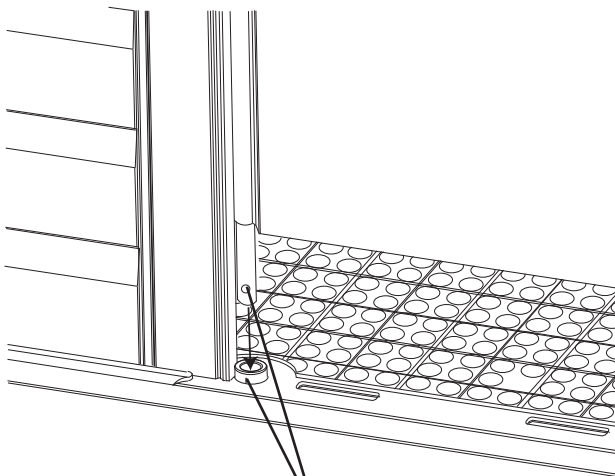

*Note: Use pliers to bend back the ends of the Cotter Pin (AHP).*



*Note: Ensure that these two holes line up, so that the Cotter Pin (AHP) can be inserted.*





## TOOLS AND HARDWARE REQUIRED FOR THIS PAGE

SEC. 9

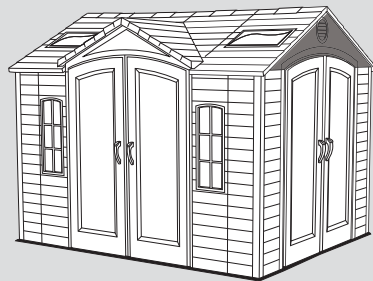

2 ADULTS REQUIRED FOR STEPS 9.3 - 9.4

SEC

### SIDE GABLE INSTALLATION

9.3

Slide the two holes in the **Side Entry Gable Assembly** down over the Door Hinge Tubes.

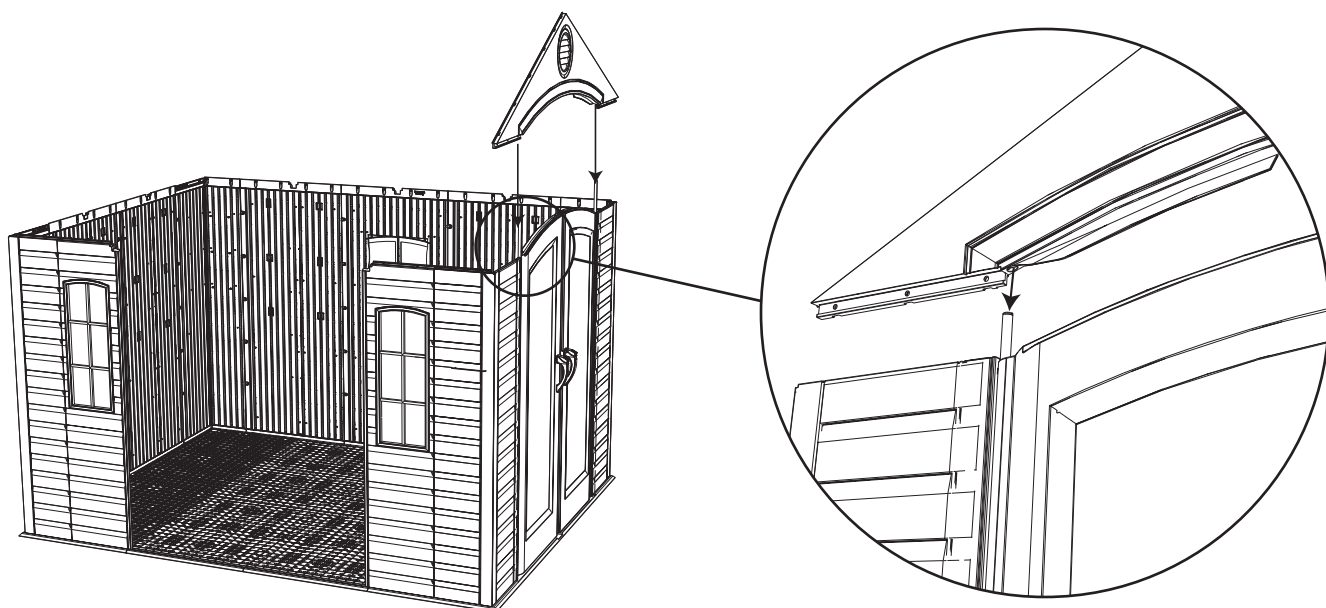

SEC

9.4

Align the holes in the sides of the Side Entry Gable Assembly with those in the top of the Corner Wall Panels and secure with six (6) **1/4" x 5/8" Pan Head Screws (ADZ)** at the locations indicated.

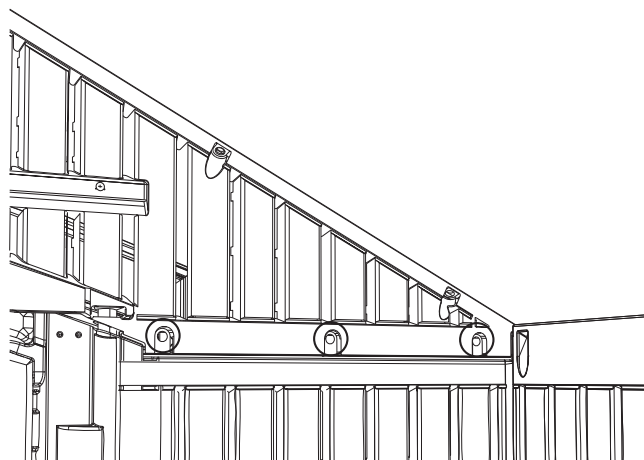
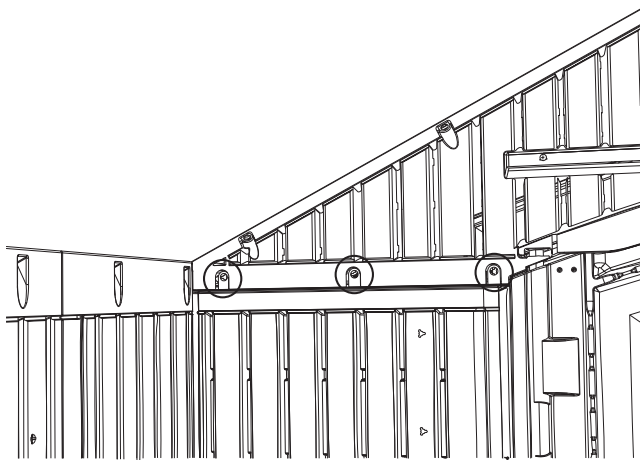



## TOOLS AND HARDWARE REQUIRED FOR THIS PAGE

SEC 9



NO HARDWARE REQUIRED FOR THIS STEP

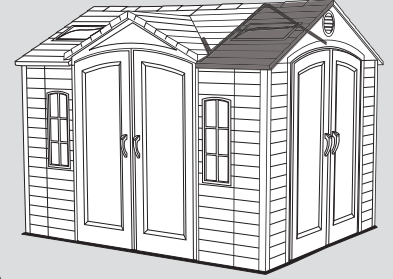

3 ADULTS REQUIRED FOR STEPS 9.5 - 9.25

SEC

### TRUSS & ROOF INSTALLATION

9.5

Place the ends of the **Right Angled Truss Assembly** into the first set of notches on the Wall Panels as shown. The angled arm faces inward.

Angled Arm

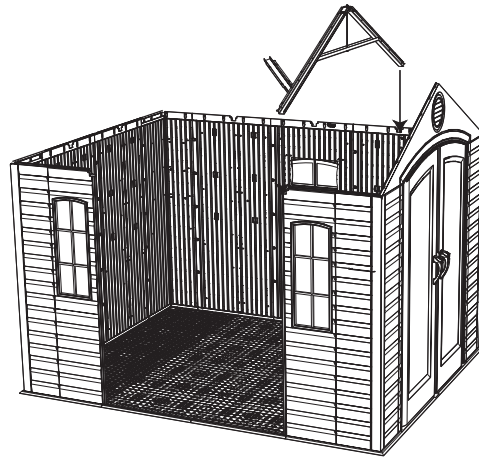
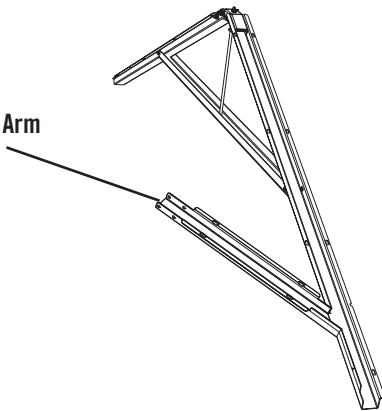

*Note: Ensure to carefully read and follow the roof installation instructions and notes. Following each step in the order listed will minimize potential complications during installation.*

SEC

9.6

While one adult holds the Right Angled Truss Assembly in place, set a **Roof Panel for Domed Skylight Assembly** onto the Right Angled Truss Assembly and Right Gable. The edge of the Roof Panel for Domed Skylight fits down inside the Truss Channels. Ensure the alignment nub in the Roof Panel fits into notch on the Truss (this helps to align the holes in the Roof Panel with those in the Truss, the Wall Panel, and Gable).

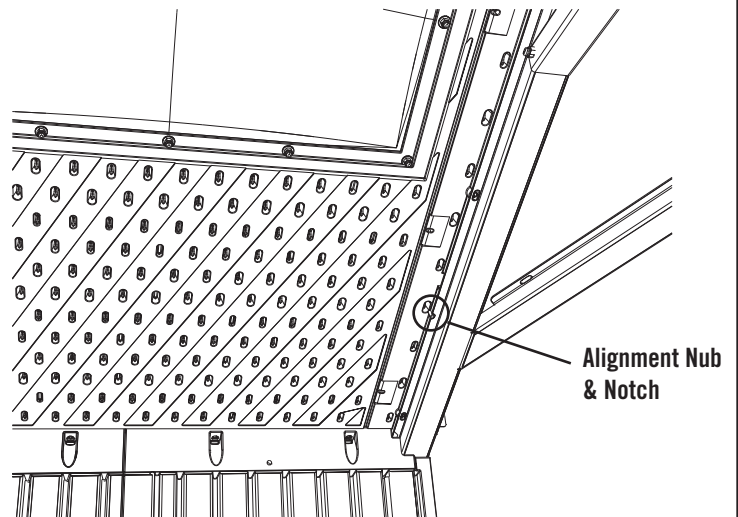
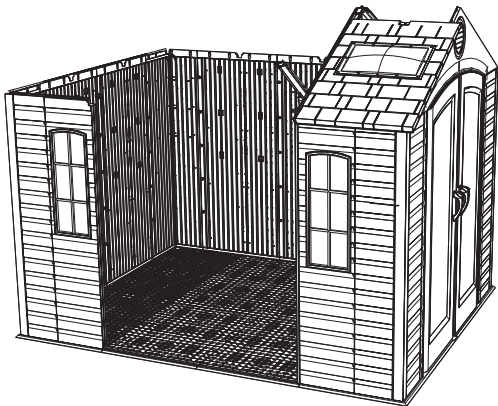

Alignment Nub & Notch

Interior Upward View



*Note: The edge of the Roof Panel fits into the Truss Assembly.*



# TOOLS AND HARDWARE REQUIRED FOR THIS PAGE

SEC. 9



(Not actual size) **AFL** (x3)

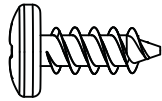

**ADZ** (x22)

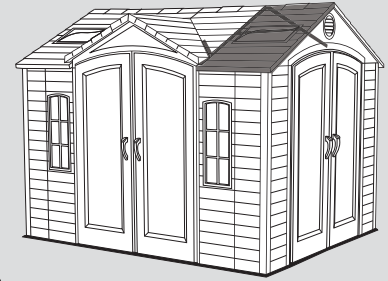

## SEC 9.7

With the Roof Panel for Domed Skylight Assembly in position between the Gable and Truss, slide two (2) **Roof Supports (AFL)** into place within the notches of the Roof Panel for Domed Skylight. The bottom lip of the Roof Panels fit over the Wall Panel. The top of the Wall Panel fits into the ridge near the bottom of the Roof Panel.

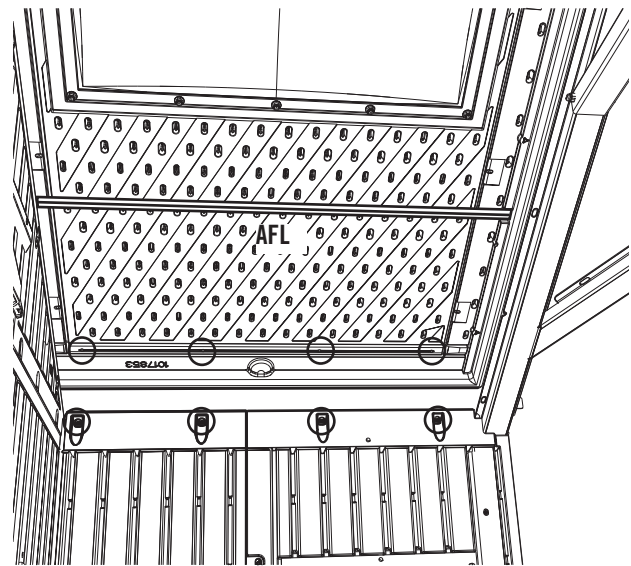
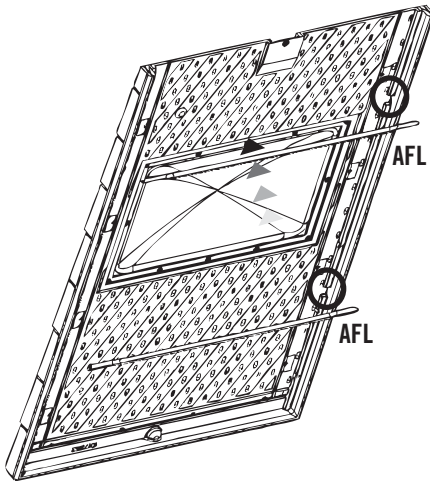

Interior Upward View



*Note: The Roof Support fits into the notches in the Roof Panel (as shown). The holes in the Roof Support Strips are for manufacturing purposes only.*

## SEC 9.8

After aligning the holes in the **Roof Panel Domed for Skylight Assembly** with those in the Wall Panels, Truss, and Gable, secure the Roof Panel for Domed Skylight to the shed using the required hardware. Then, secure a **Roof Panel (AGQ)** to the rear of the shed. A regular Roof Panel only uses one (1) **Roof Support (AFL)**.



*Note: Use only a hand screwdriver for this step.*

AGQ

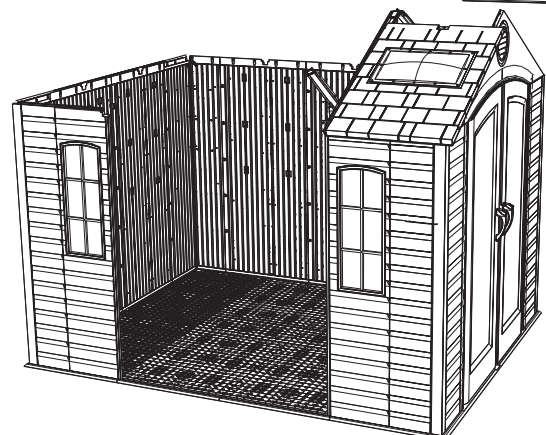
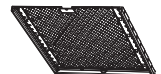

*Note: Ensure the ridge in the bottom of the Roof Panel fits into the top of the wall.*



## TOOLS AND HARDWARE REQUIRED FOR THIS PAGE

SEC 9



(Not actual size) AFL (x3)



ADZ (x36)

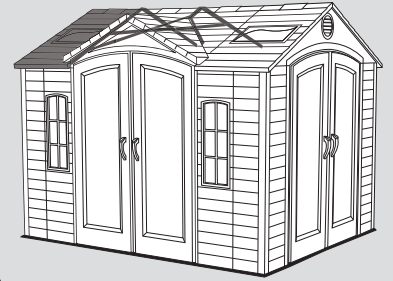

SEC

9.9

Attach the Left Side Gable Assembly to the shed as shown and secure with fourteen (14) 1/4" x 5/8" Pan-Head Screws (ADZ). Follow steps 9.5 - 9.8 to install the Left Angled Truss Assembly, a Roof Panel for Domed Skylight Assembly, Roof Panel (AGQ), and Roof Supports (AFL) on the left side of the shed.

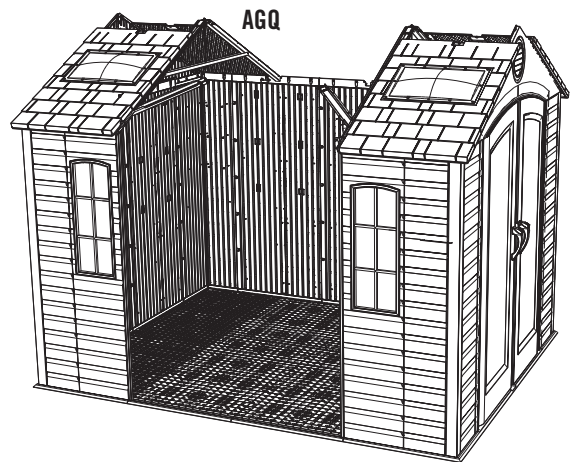
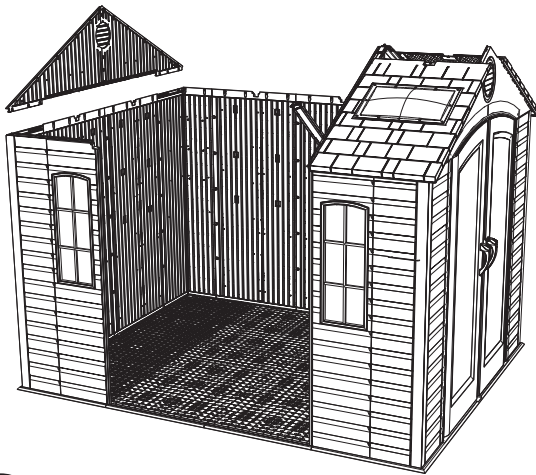

SEC

9.10

Set the back end of the Center Truss Assembly into the notch in the center of the rear Wall and the front, angled ends into the Left and Right Angled Truss Assemblies.

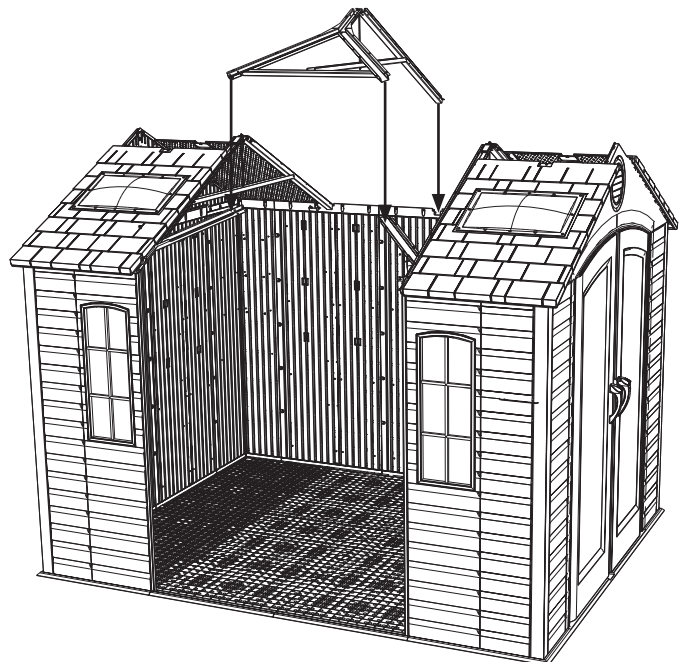



## TOOLS AND HARDWARE REQUIRED FOR THIS PAGE

SEC. 9



7/16"



ADJ (x4)

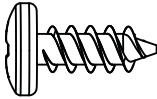

ADZ (x20)



(Not actual size) AFL (x2)

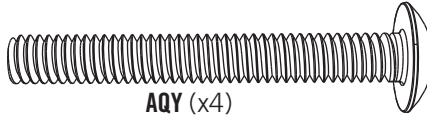

AQY (x4)

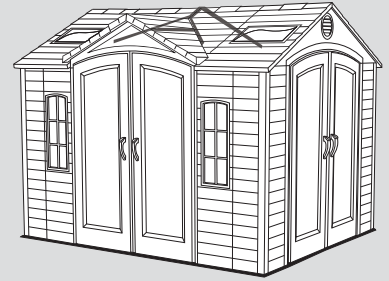

SEC

9.11

With the front arms of the Center Truss Assembly in the angled arms of the Left and Right Angled Truss Assemblies, secure the **Center Truss Assembly** to the Left and Right Angled Truss Assemblies using the required hardware. Tighten hardware securely.

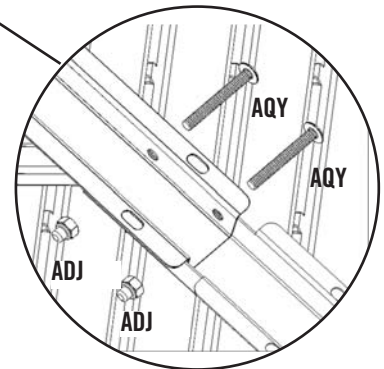
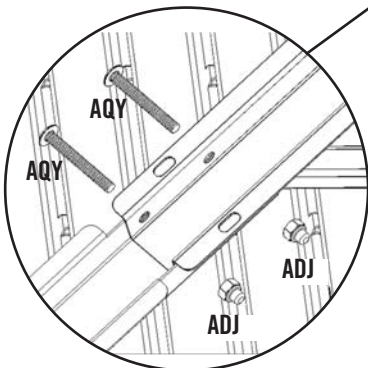
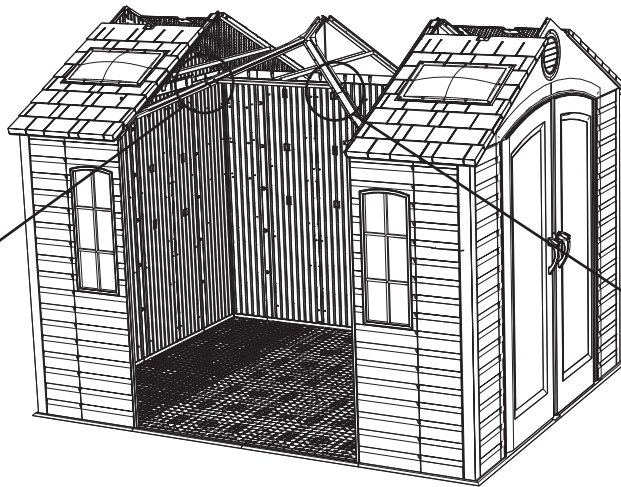

SEC

9.12

Install the remaining **Roof Panels (AGQ)** and **Roof Supports (AFL)** to the rear of the shed using twenty (20) 1/4" x 5/8" **Pan-Head Screws (ADZ)**. The Roof Panels fit down inside the Truss Gutter Channels.

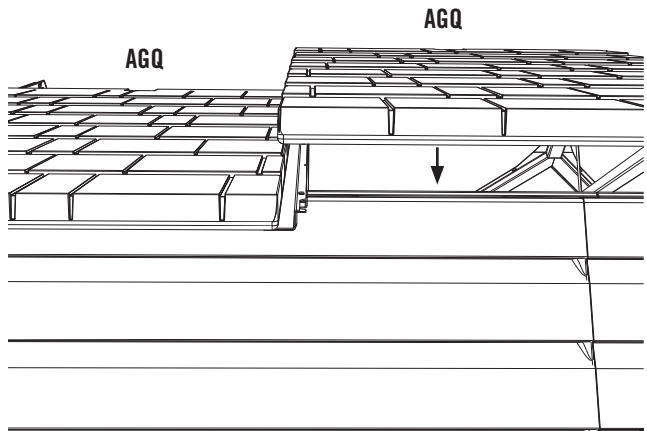
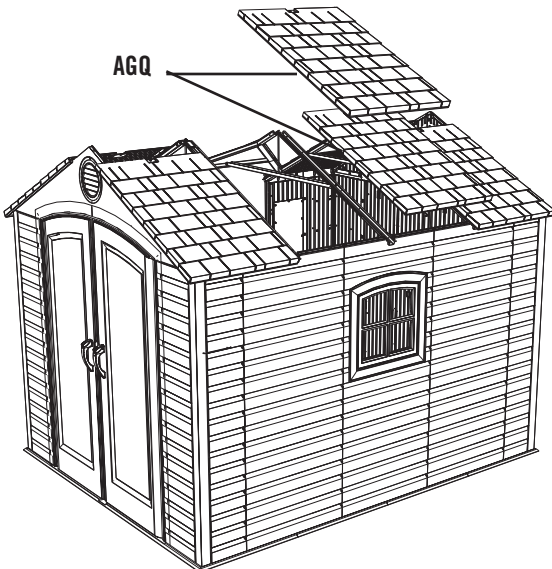

Rear of Shed

**!** Note: Roof Panels butt up against each other inside the Truss Gutter Channels.



## TOOLS AND HARDWARE REQUIRED FOR THIS PAGE

SEC 9



AHP (x2)

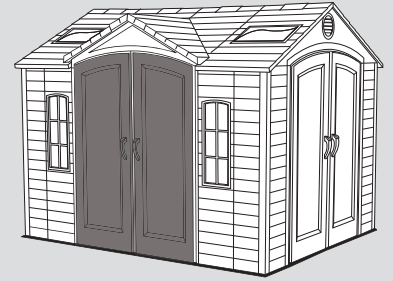

SEC

9.13

### DOOR & ENTRY GABLE INSTALLATION

Insert the hinge tube of the **Left, Front Door Assembly (Notched)** into the left, front Door Hinge Bushing as shown. Ensure bottom of Hinge fits completely into the Door Hinge Bushing.

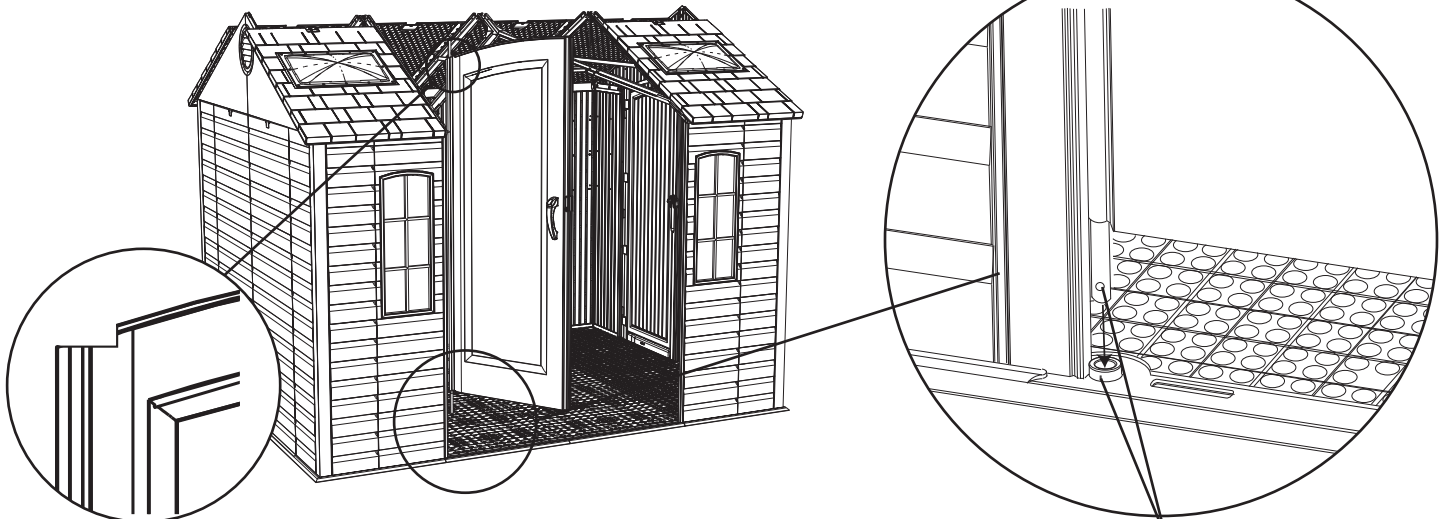

*Note: The Left & Right Front Doors assembled here have notches at the top corners.*



*Note: Ensure that these two holes line up, so that the Cotter Pin (AHP) can be inserted.*

SEC

9.14

Insert a **Cotter Pin (AHP)** through the Bushing and Door Hinge. Use a pair of pliers to bend the ends of the Cotter Pins outward. **Repeat steps 9.13 & 9.14 for the Right, Front Door Assembly (Notched).**

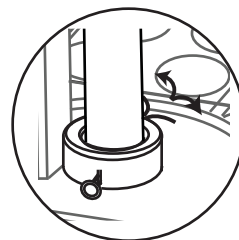
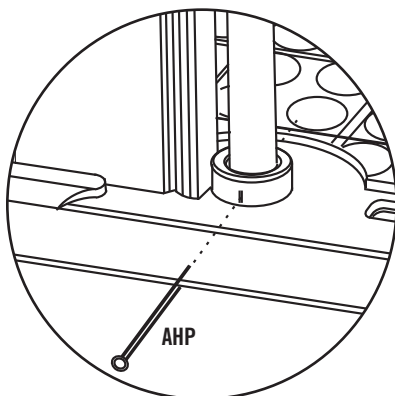

*Note: Use pliers to bend back the ends of the Cotter Pin (AHP).*



## TOOLS AND HARDWARE REQUIRED FOR THIS PAGE

SEC. 9

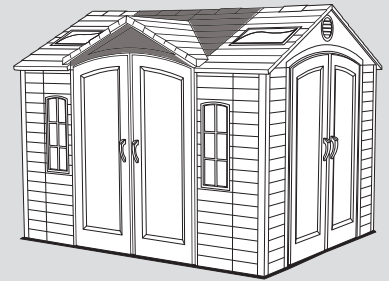

SEC

9.15

While another adult holds the Doors in place, slide the **Entry Gable Assembly** over the Door Hinges. The tops of the hinges will fit into the holes on each end of the Gable.

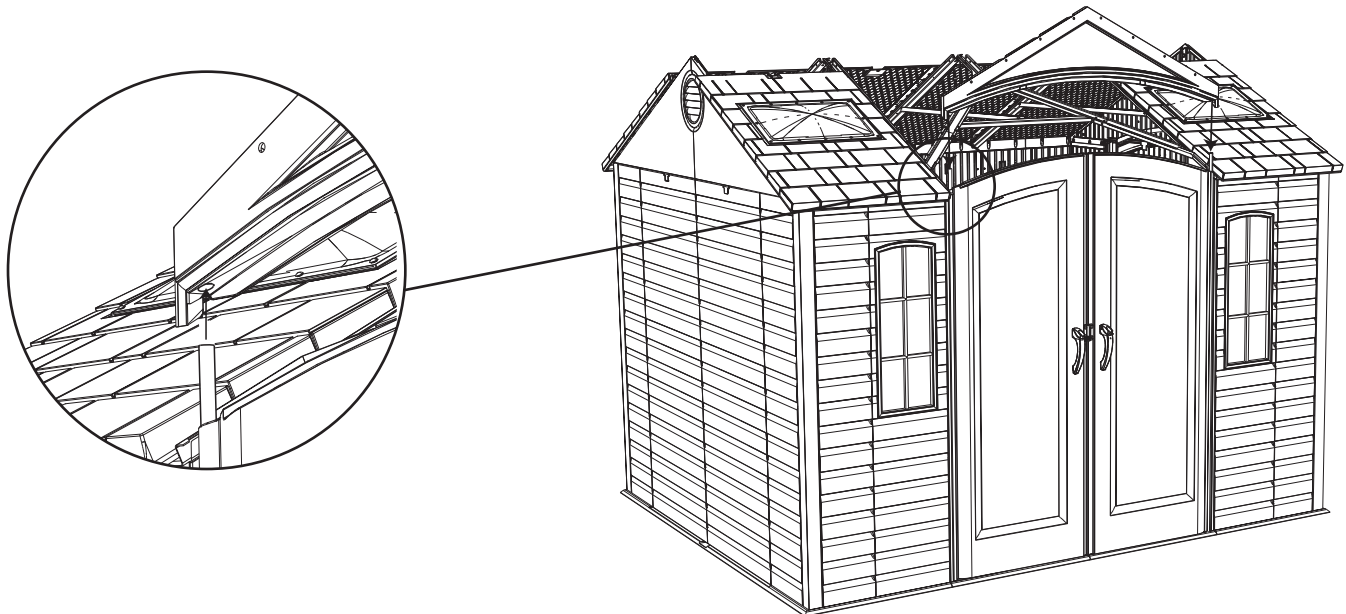

SEC

9.16

Attach the **Upper Left and Right Front Gable Roof Panels (BDT & BDU)** using seven (7) 1/4" x 5/8" Pan-Head Screws (ADZ) per Panel at the locations indicated.

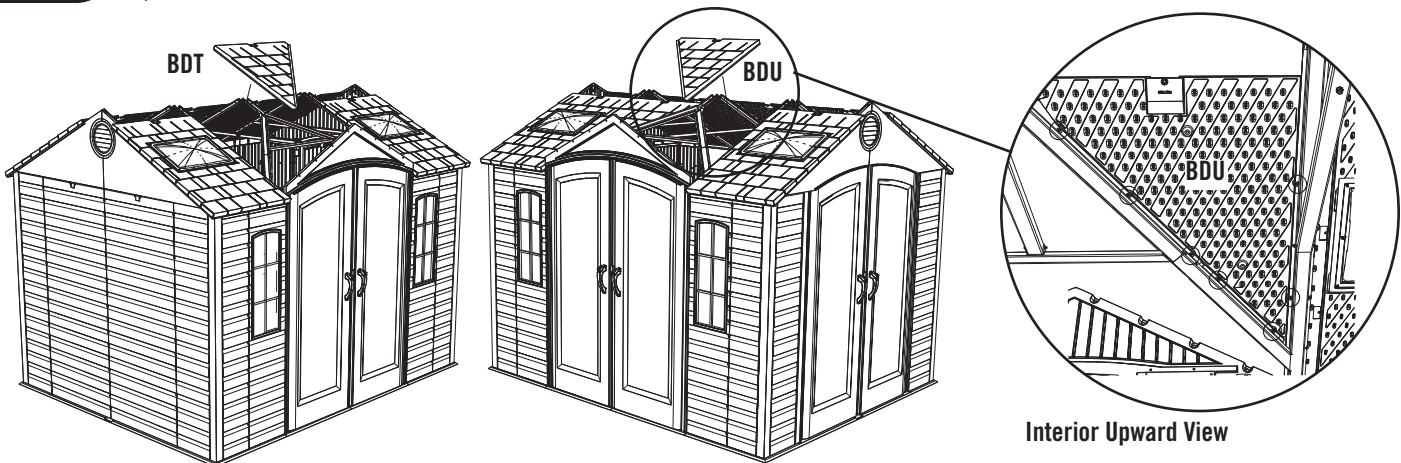



# TOOLS AND HARDWARE REQUIRED FOR THIS PAGE

SEC 9

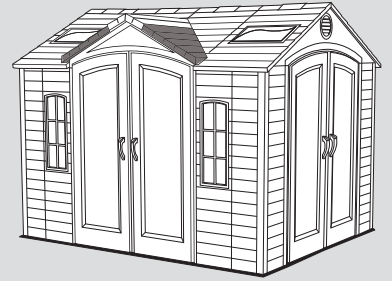

SEC

9.17

Align the holes in the **Lower Left Front Gable Roof Panel (BDR)** with those in the Angled Truss and Front Gable Assemblies and secure with the required hardware. **Repeat this step for the Lower Right Front Gable Roof Panel (BDS).**

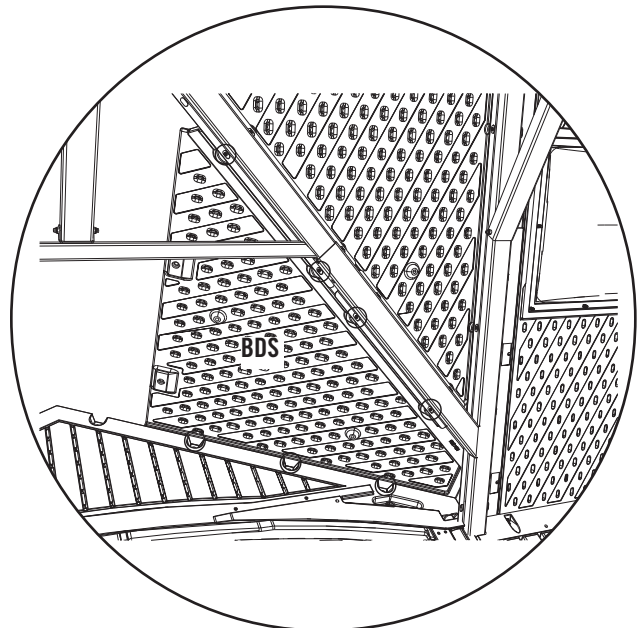
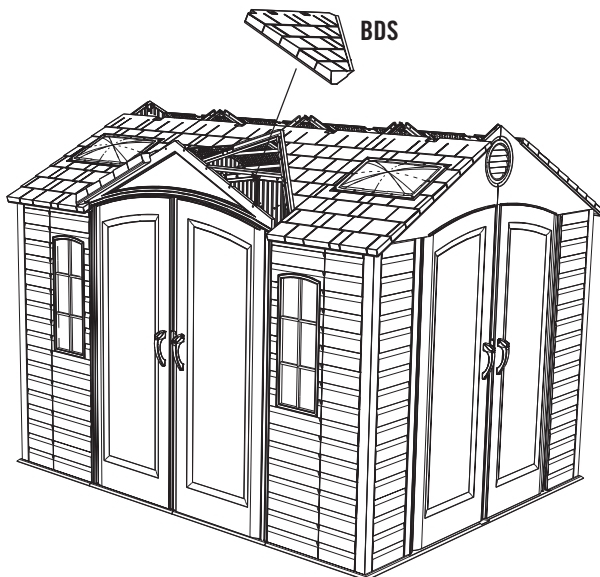
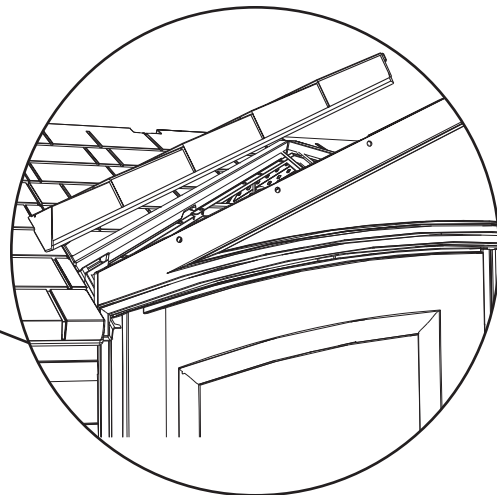
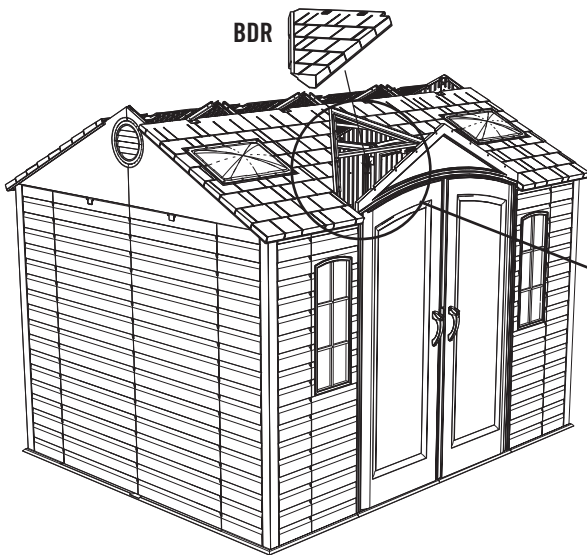

Interior Upward View





## TOOLS AND HARDWARE REQUIRED FOR THIS PAGE

SEC 9

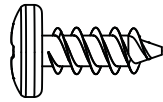

ADZ (x10)

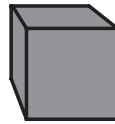

AJA (x2)

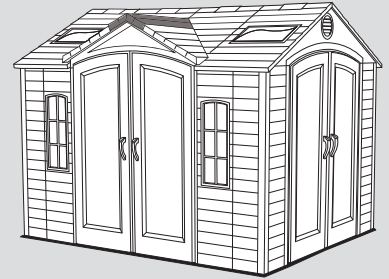

SEC

9.18

Insert two **Foam Cubes (AJA)** inside the Center Truss Assembly at the location shown. The purpose of the Foam Cubes is to block light entering at this point.

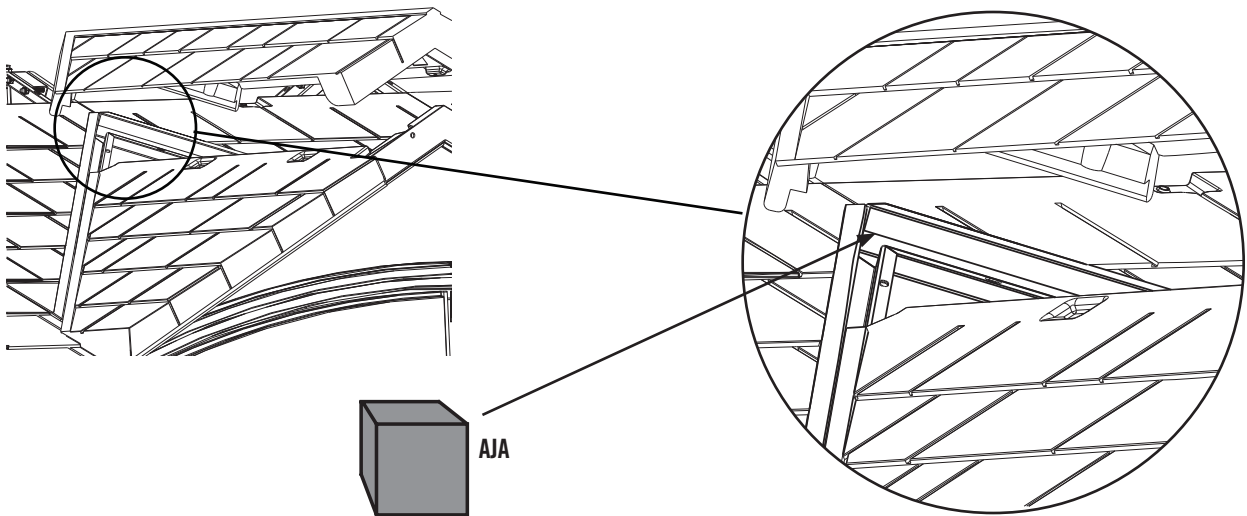

SEC

9.19

Attach the **Entry Gable Roof Cap (BDW)** at the locations indicated using the required hardware.

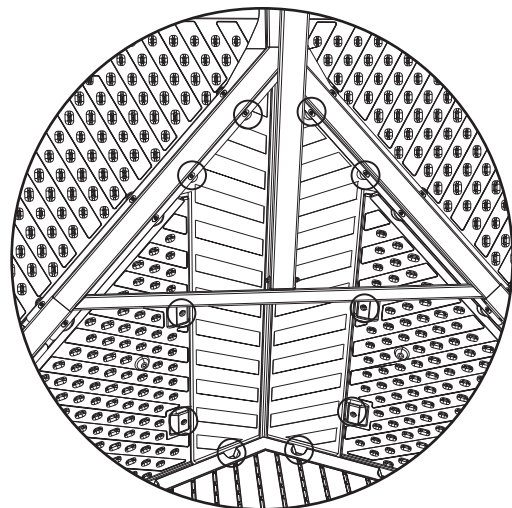
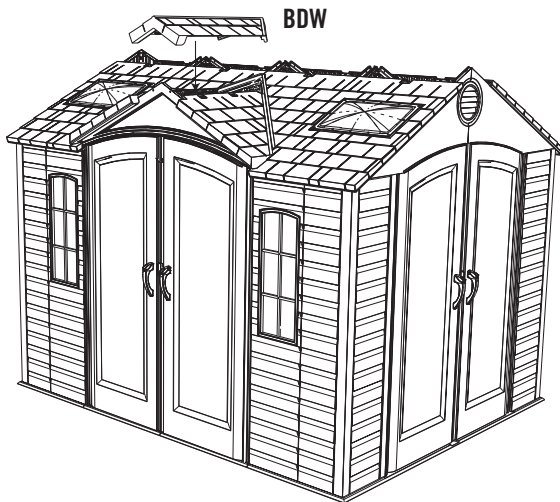

Interior Upward View



*Note: Attach the Roof Cap to the Panels and the Gable at the locations shown.*



## TOOLS AND HARDWARE REQUIRED FOR THIS PAGE

SEC 9



ARA (x1) (Included)

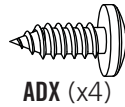

ADX (x4)

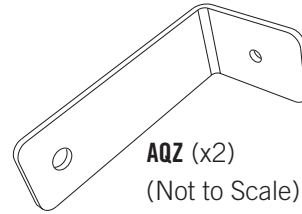

AQZ (x2)  
(Not to Scale)

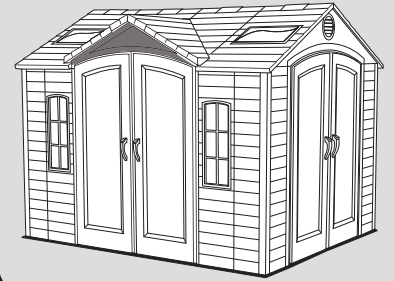

SEC

9.20

Loosely attach the **Entry Gable Bracket (AQZ)** to the Truss at the location shown with a **Screw (ADX)**. Turn the Entry Gable Bracket into position and use the hole as a guide for the **1/8" Drill Bit (ARA)**. Carefully drill through the Gable and into the Door Hinge (be sure that the bit goes into the Hinge Tube but not all the way through).

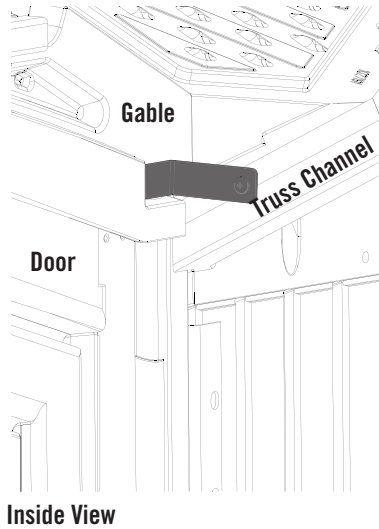
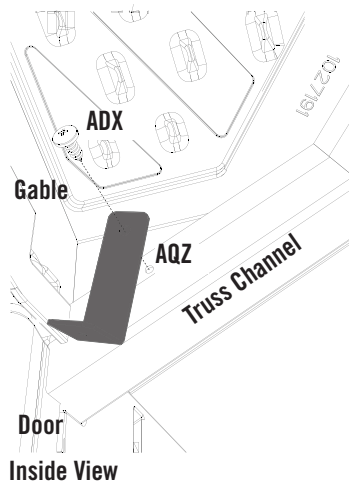

### WARNING

While performing this step, each person should use protective eye glasses to help prevent serious eye injury.



### CAUTION

Do not drill all the way through the Gable. Only drill into the Hinge Tube.

SEC

9.21

Insert two (2) **#10 x 1/2" Pan-Head Screws (ADX)** through the Bracket and into the Gable and Door Hinge. **Repeat** steps 9.20 - 9.21 for the other end of the Front Entry Gable.

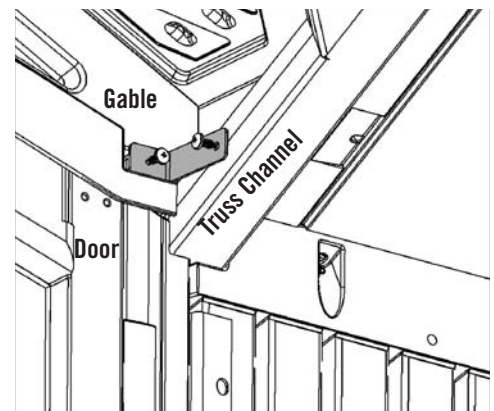

Inside View



*Note: The front of the Panel fits over the Gable.*



## TOOLS AND HARDWARE REQUIRED FOR THIS PAGE

SEC. 9



ADZ (x28)

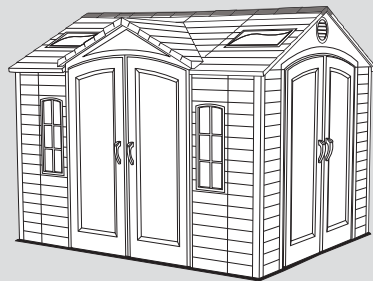

SEC

9.22

Starting at the right side of your shed, attach the **Right End Roof Cap (AFW)** to the Roof Panels and Right Side Entry Gable. Continue moving to the left attaching the **Center Roof Caps (AFY)**. Finally attach the **Left End Roof Cap (AGG)** to the Roof Panels and Gable.



*Note: Use only a hand screwdriver for this step.*

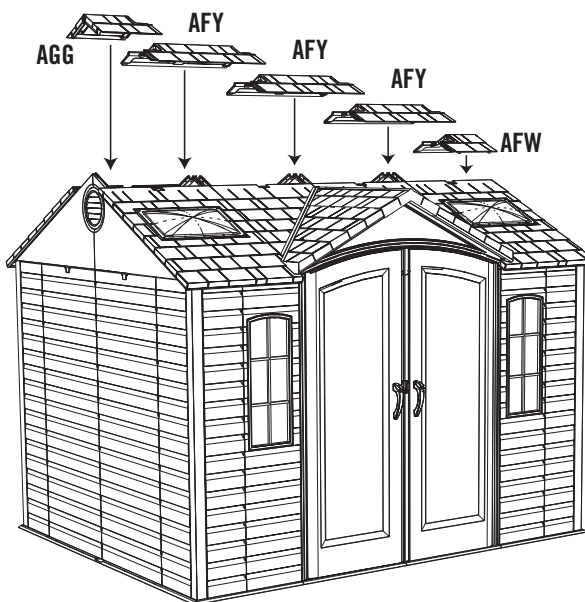

### CAUTION

Only hand tighten screws. Do not overtighten. Overtightening may damage plastic parts and void warranty.

SEC

9.23

Connect the Roof Caps to each other using **1/4" x 5/8" Pan-Head Screws (ADZ)**.

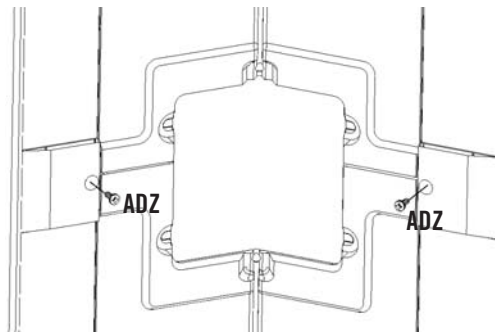



## TOOLS AND HARDWARE REQUIRED FOR THIS PAGE

SEC 9

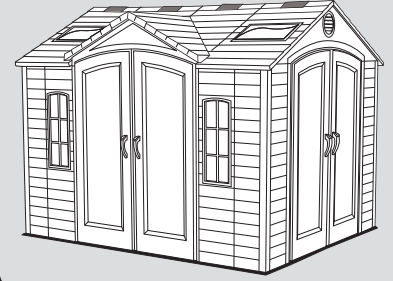
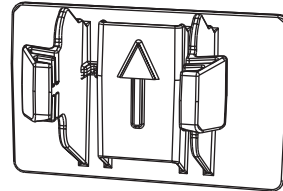
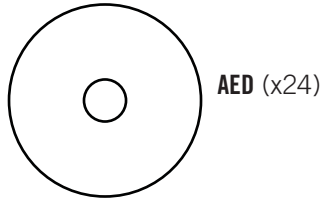

SEC

9.24

### SKYLIGHT INSTALLATION

Pre-fold **Skylight (AHC)** before installing. Push folded Skylight up through opening between Roof Caps; open Skylight; use tabs to pull Skylight down into place. Fasten Skylight in place with **#10 x 1" Fender Washers (AED)** and **#10 x 1/2" Pan-Head Screws (ADX)** (pull down on tabs while inserting screw to provide resistance). Repeat this step for each Skylight.

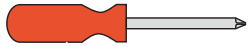

Note: Use only a hand screwdriver for this step.

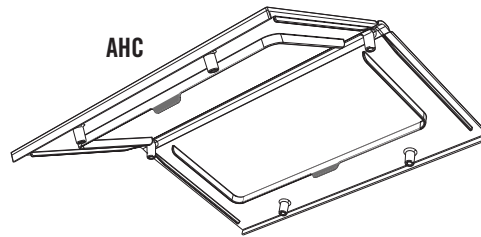

AHC AHC AHC AHC

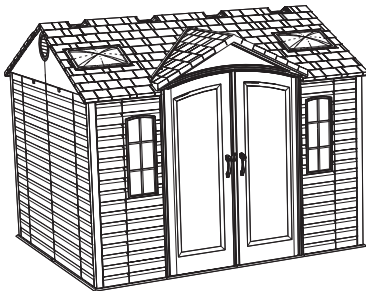

Pull down on tabs while inserting screws.

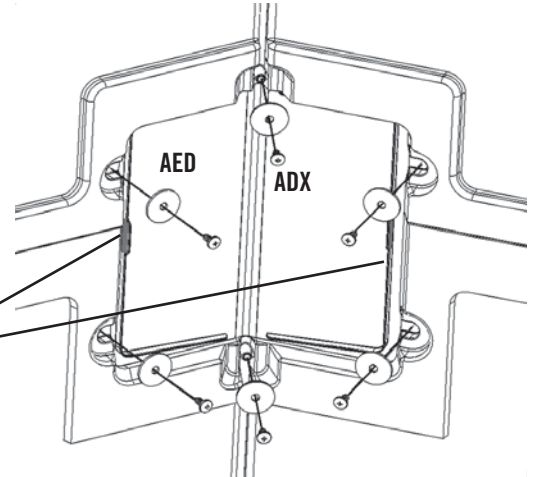

SEC

9.25

### GABLE CLIP INSERTION

Insert the **Truss Hole Inserts (AXX)** into the side walls as shown.

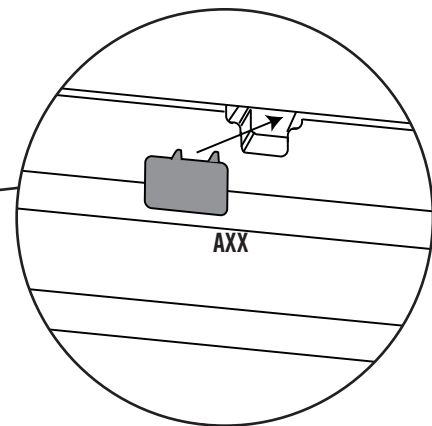
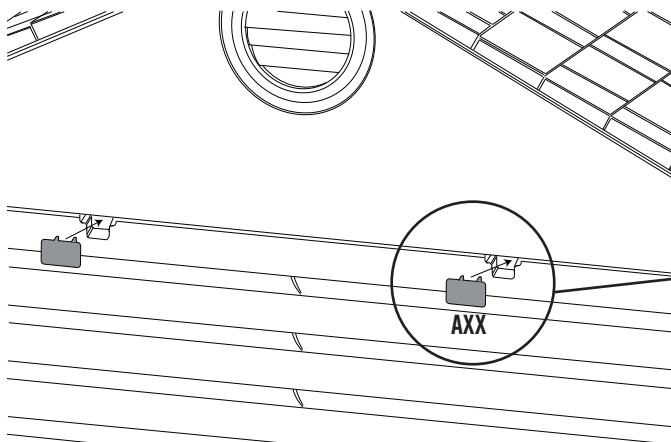

Note: Gable Clip can only be inserted with the arrow pointing up.



## TOOLS AND HARDWARE REQUIRED FOR THIS PAGE

SEC. 9

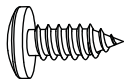

ADX (x4)

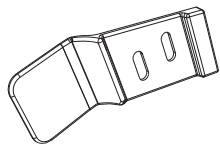

AIM (x1)

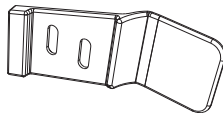

AIC (x1)

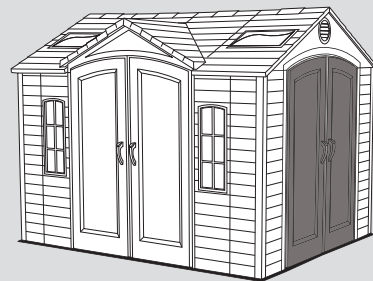

SEC

9.26

### GAP FLAP INSTALLATION

Attach the **Right & Left Gap Flaps (AIM & AIC)** to the top, right and left corners of the Side Doors as shown. Before completely tightening the **#10 x 1/2" Pan-Head Screws (ADX)**, slide the Gap Flaps up until they cover any gap between the tops of the Doors and the Gable.

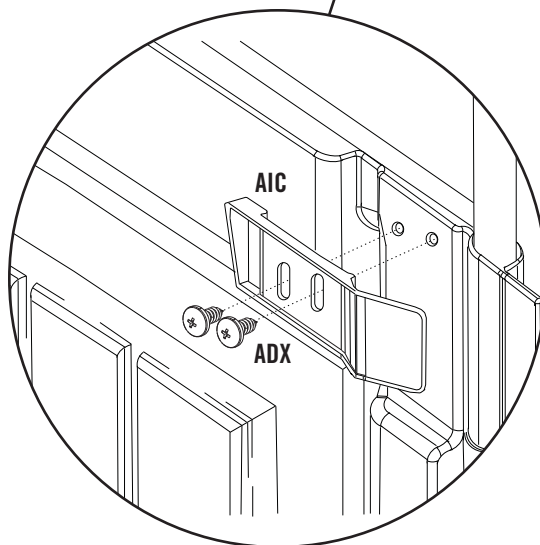
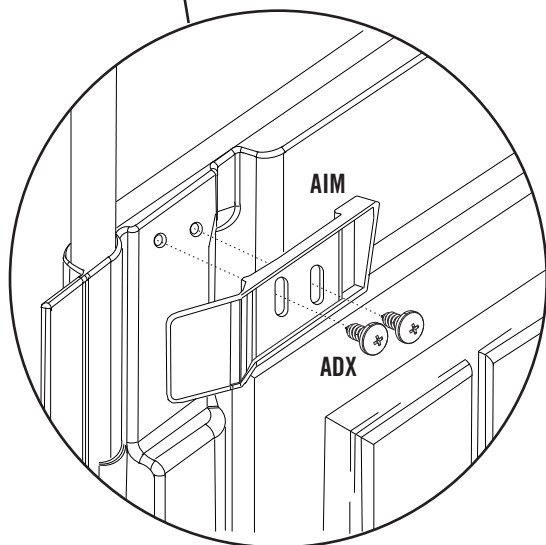
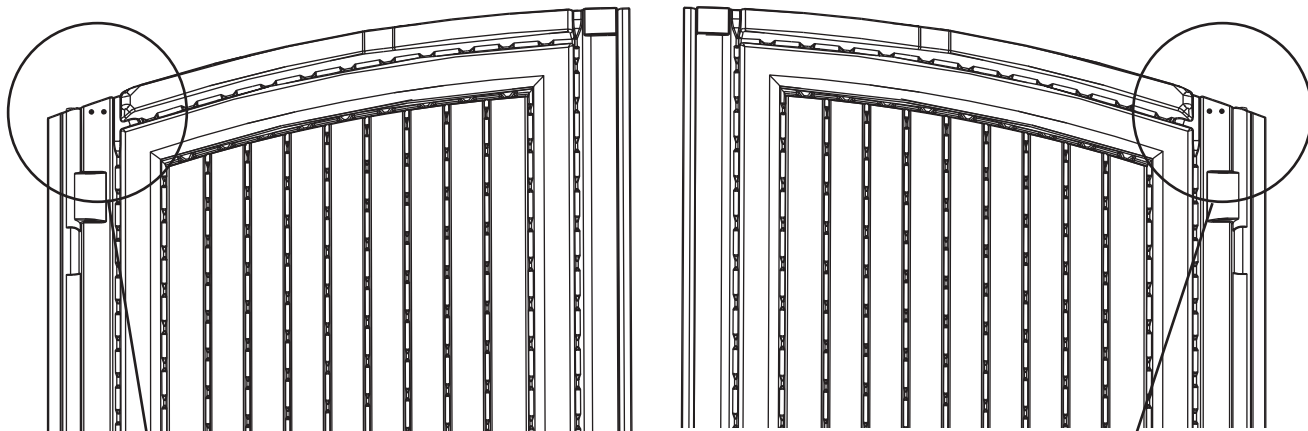

## SEC 10 WINDOW INSTALLATION

### HARDWARE REQUIRED

Hardware shown at actual size

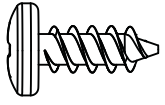

**ADZ** (x4)  
1/4" x 5/8" Pan-Head Screw

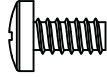

**ADY** (x1)  
#10 x 3/8" Pan-Head Screw

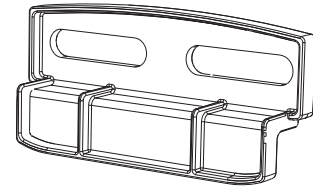

**AIS** (x2)  
Window Latch

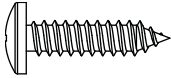

**ADW** (x28)  
#10 x 3/4" Pan-Head Screw

### METAL PARTS REQUIRED

NO METAL PARTS REQUIRED FOR THIS SECTION

### PLASTIC PARTS REQUIRED

Part shown at 4% of actual size

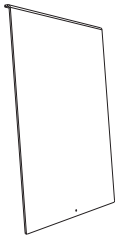

**AHE** (x1)  
Window

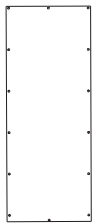

**BDV** (x2)  
Half-Wall Window

### TOOLS REQUIRED



Phillips Screwdriver



Safety Glasses



## TOOLS AND HARDWARE REQUIRED FOR THIS PAGE

SEC 10



ADW (x28)

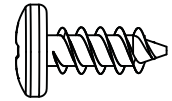

ADZ (x4)

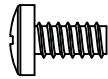

ADY (x1)

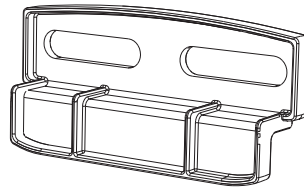

AIS (x2)

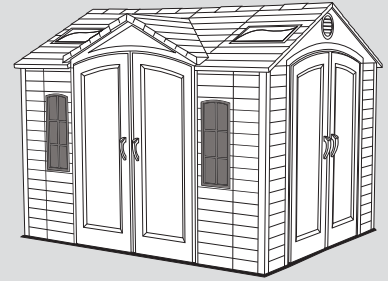

SEC

10.1

Remove the plastic protective film from **both sides** of the **Window for Half-Window Wall Panel (BDV)** and attach the Window for Half-Window Wall Panel to the Right Half-Window Wall Panel using fourteen (14) #10 x 3/4" Pan-Head Screws (ADW). Repeat this step for the Left Half-Window Wall Panel.

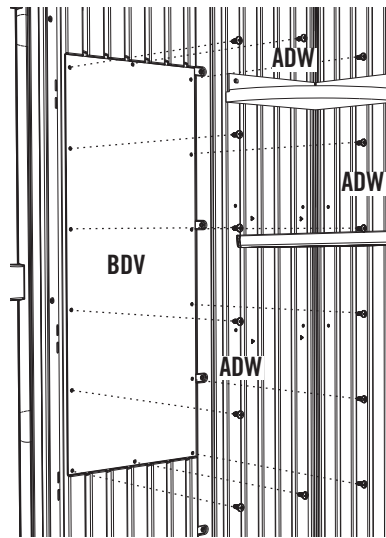
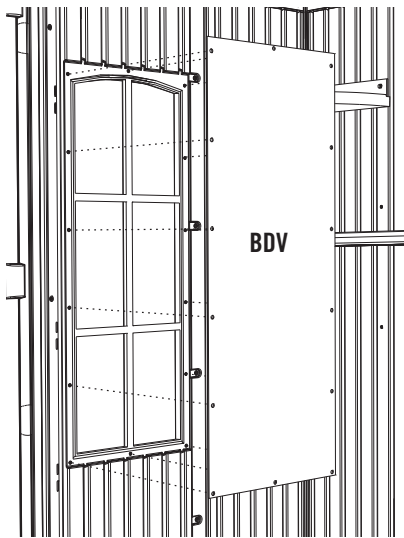

SEC

10.2

## WINDOW INSTALLATION

Remove the protective plastic film from **both sides** of the **Window (AHE)** and slide the Window into the grooves along the sides of the opening in the Window Wall Panel (Fig. 1). Insert the #10-24 x 3/8" Pan-Head Screw (ADY) into the hole at the bottom of the Window (Fig. 2) until flush. Attach a **Window Latch (AIS)** above each corner of the Window as shown. When tightening the 1/4" x 5/8" Pan-Head Screws (ADZ), ensure the Window Latches slide freely (Fig. 3). **Do not overtighten.**

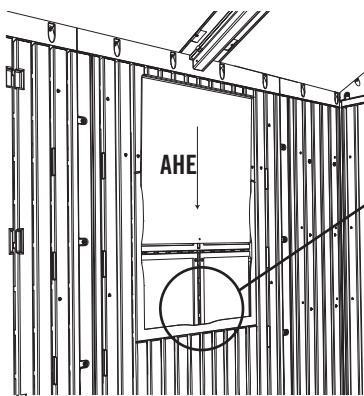

Fig. 1

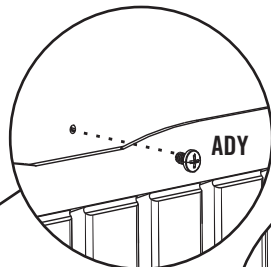

Fig. 2

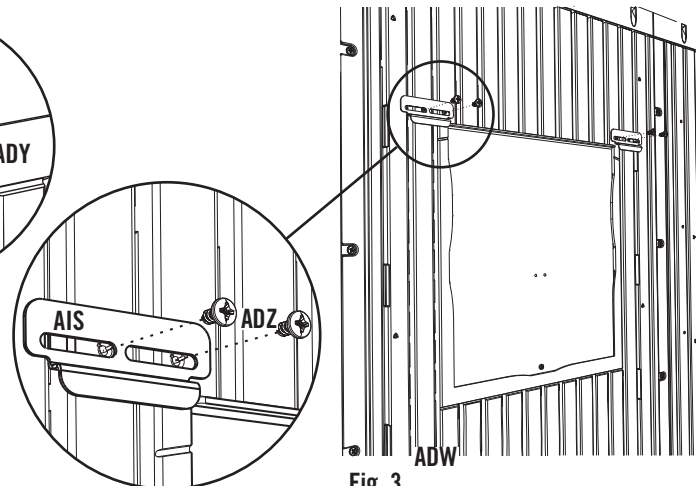

Fig. 3



*Note: Insert Window with bent edge at top and pointing away from the wall.*

# SEC 11 SHELF INSTALLATION

## HARDWARE REQUIRED

Hardware shown at actual size

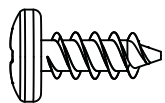

**ADZ** (x14)  
1/4" x 5/8" Pan-Head Screw

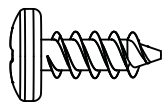

**ADZ** (x16)  
1/4" x 5/8" Pan-Head Screw

## HARDWARE BAGS REQUIRED: BHH, BHI (x4)

Part shown at 15% of actual size



**AIY** (x2)  
Shelf Bracket

## METAL PARTS REQUIRED

Part shown at 8% of actual size

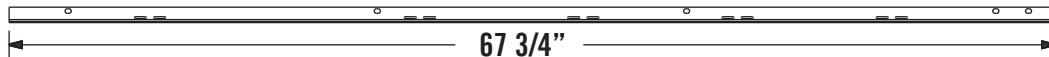

**AFM** (x2)  
Shelf Support Channel

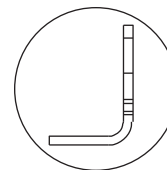

## METAL PARTS KIT REQUIRED: CRG

## PLASTIC PARTS REQUIRED

Part shown at 4% of actual size



**AFV** (x1)  
90" Shelf

Part shown at 8% of actual size

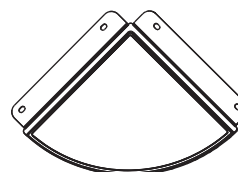

**AFZ** (x4)  
Corner Shelf

## TOOLS REQUIRED



Phillips Screwdriver



Safety Glasses





## TOOLS AND HARDWARE REQUIRED FOR THIS PAGE

SEC 11

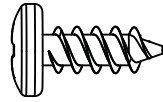

ADZ (x8)

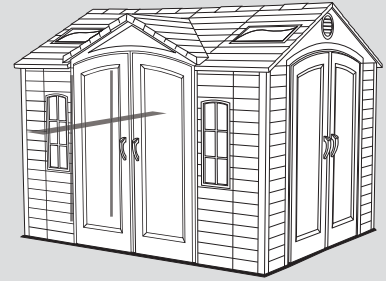

SEC

11.1

### SHELF SUPPORT CHANNEL INSTALLATION

Insert a **Shelf Support Channel (AFM)** into the groove in the Wall Panels directly below the Right Truss notch, align the four holes in the Wall/Shelf Support Channel with those along the groove and secure with four (4) **1/4" x 5/8" Pan-Head Screws (ADZ)**. Insert a second Shelf Support Channel in the slot directly to the right of the Left Truss Notch and secure with four (4) 1/4" x 5/8" Pan-Head Screws.

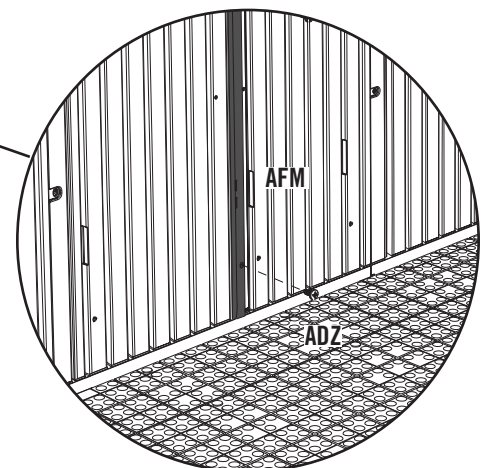
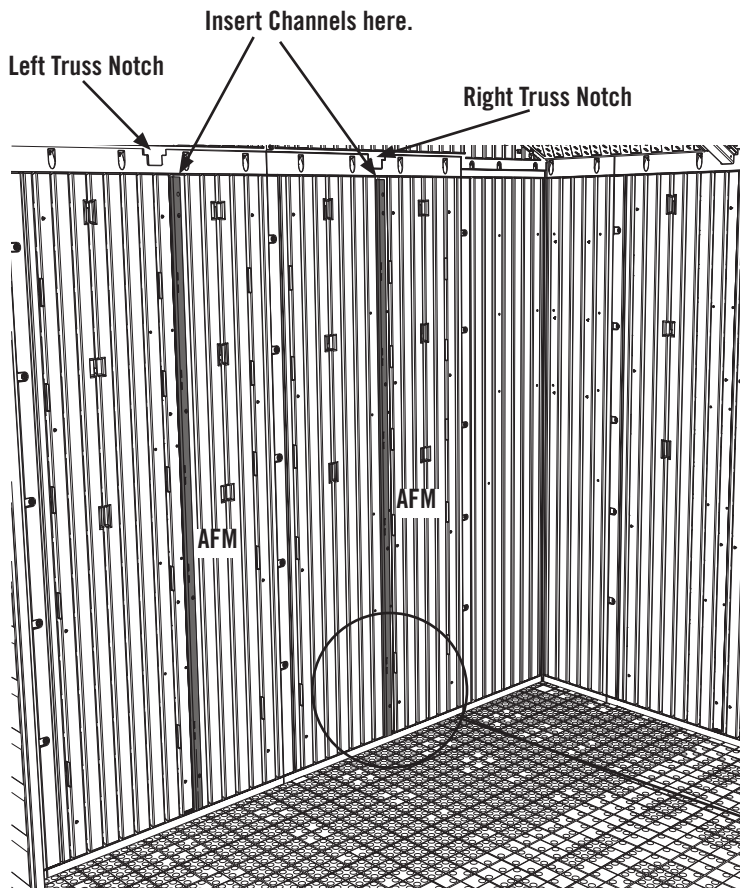



## TOOLS AND HARDWARE REQUIRED FOR THIS PAGE

SEC. 11

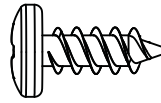

ADZ (x6)

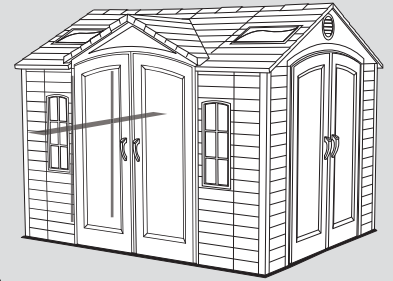

SEC

### 90" SHELF INSTALLATION

11.2

Set a **Shelf Support Bracket (AIY)** into the slots of each of the Shelf Support Channels. The slots must be at the same height.

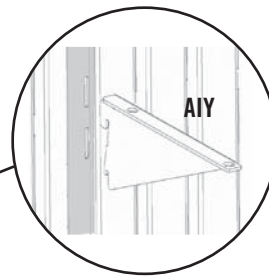
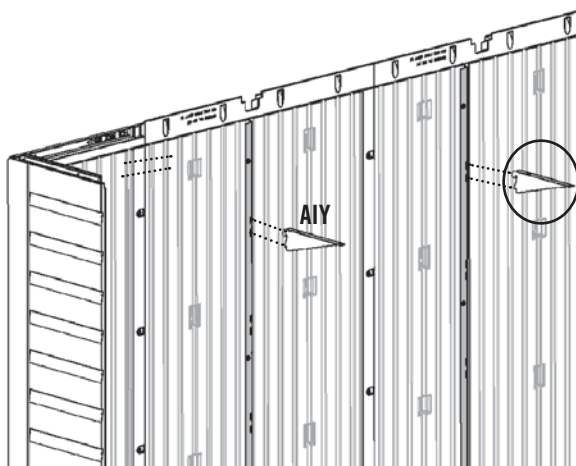

**!** Note: Insert Shelf Support Bracket at an angle.

SEC

11.3

Fold up flaps on the end of **90" Shelf (AFV)**. Set Shelf on Brackets with indentations toward wall, and secure with six (6) **1/4" x 5/8" Phillips Pan-Head Screws (ADZ)**.

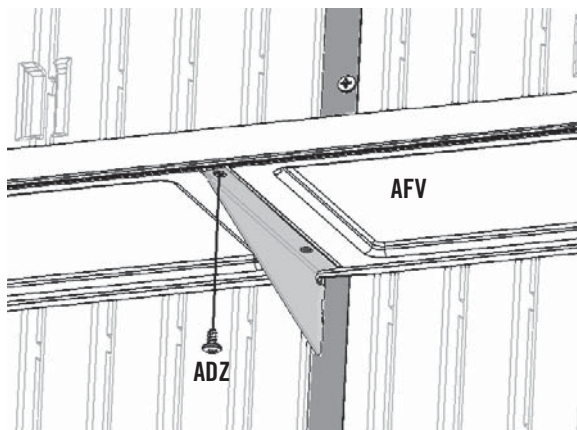

Upward view

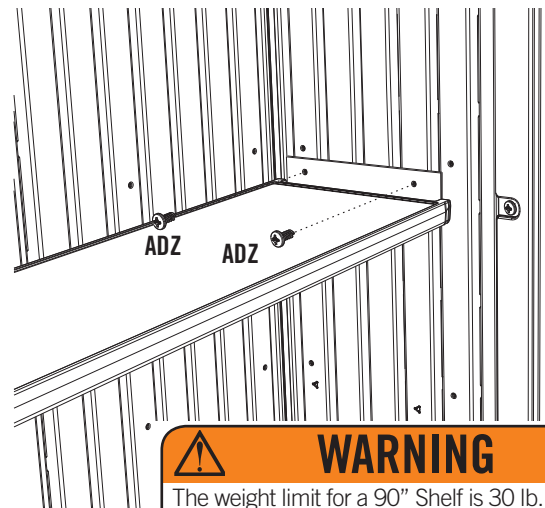

**!** **WARNING**  
The weight limit for a 90" Shelf is 30 lb. per 30" section of Wall Panel. Failure to heed this warning could result in property damage and/or personal injury.

**!** Note: There are only holes for screws along front side of the Shelf (front is labeled "Front" on underside of Shelf).



## TOOLS AND HARDWARE REQUIRED FOR THIS PAGE

SEC. 11

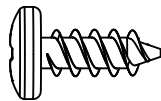

ADZ (x16)

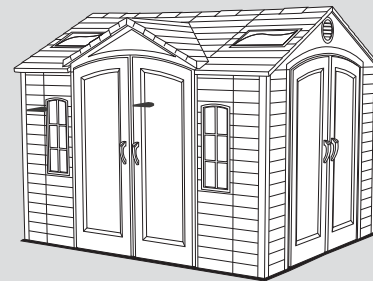

SEC

11.4

### CORNER SHELF INSTALLATION

Note the top set of pre-made holes in the Rear, Left Corner Wall Panel (fig. 1). Fold up edges of a **Corner Shelf (AFZ)**. Line-up holes in the Corner Shelf with the top set of pre-made holes in the Rear, Left Corner Wall Panel (Fig. 2). Secure with four (4) **1/4" x 5/8" Phillips Pan-Head Screws (ADZ)**. Repeat this step for each corner of the shed.

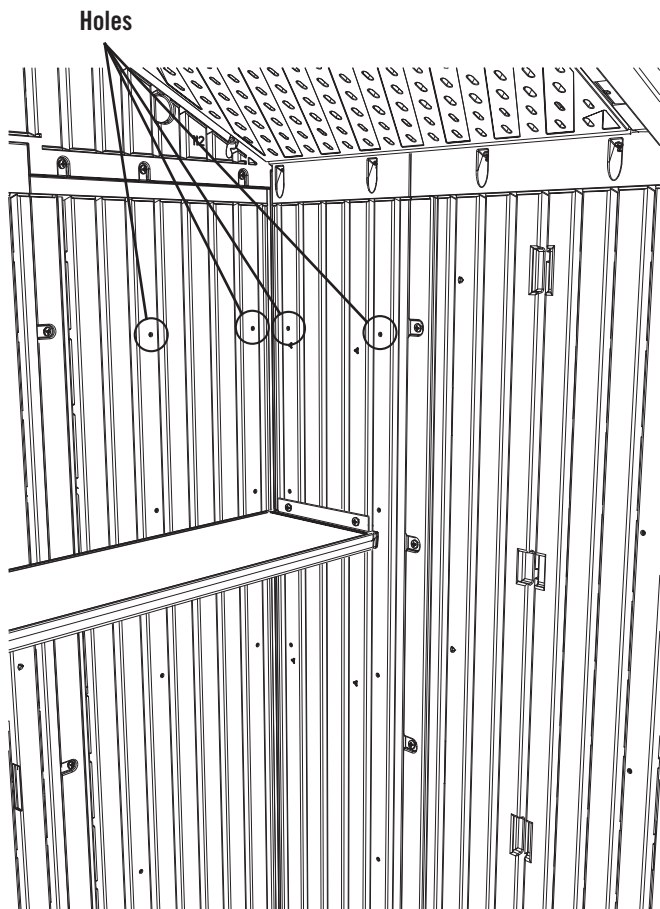

Fig. 1

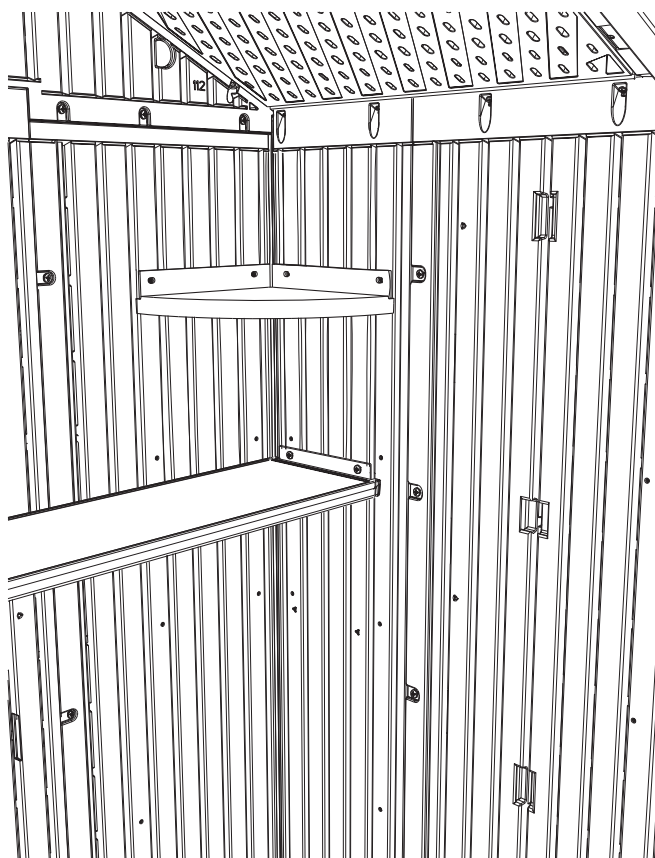
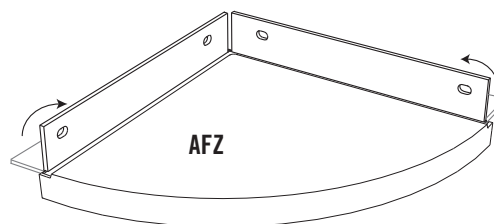

Fig. 2



### WARNING

The weight limit for a Corner Shelf is 10 lb. per Shelf. Failure to heed this warning could result in property damage and/or personal injury.

## SEC 12 PEGBOARD STRIP INSTALLATION

### HARDWARE REQUIRED

Hardware shown at actual size

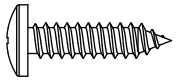

**ADW** (x10)  
#10" x 3/4" Pan-Head Screw

### HARDWARE BAGS REQUIRED: BHC, BHD

Hardware shown at 50% of actual size

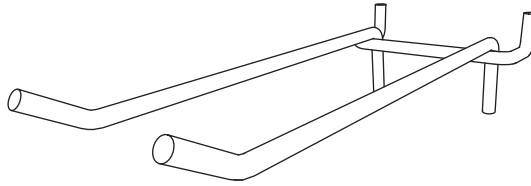

**AIG** (x1)  
4" Double-Arm Hook

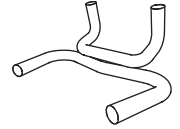

**AIJ** (x2)  
Toolholder

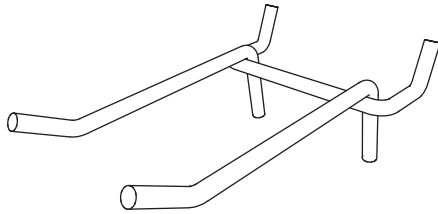

**AIF** (x1)  
2" Double-Arm Hook

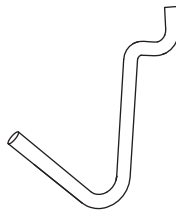

**AIH** (x3)  
J-Hook

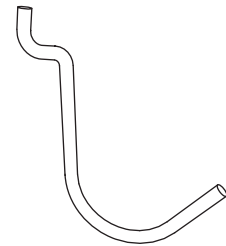

**AII** (x3)  
L-Hook

### PLASTIC PARTS REQUIRED

Parts shown at 15% of actual size

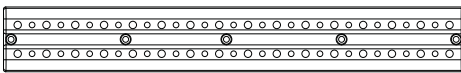

**AFU** (x2)  
Pegboard Strip

### TOOLS REQUIRED



Phillips Screwdriver



Safety Glasses



Level



## TOOLS AND HARDWARE REQUIRED FOR THIS PAGE

SEC 12

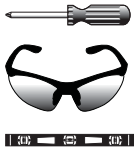

ADW (x10)

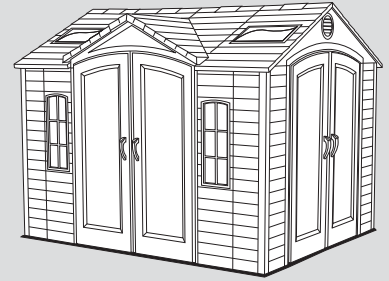

SEC

### PEGBOARD STRIP INSTALLATION

12.1

Using a level, position the **Pegboard Strip (AFU)** in any desired location along a Wall Panel wall. Screw the Pegboard Strip to the Wall using five (5) **#10 x 3/4" Phillips Pan-Head Screws (ADW)**. See Note. Repeat this step for second Pegboard Strip.

**!** Note: The Pegboard Strip is screwed directly into the plastic. Line up the Strip anywhere on Wall so holes are over plastic (and not over a groove in the Wall).

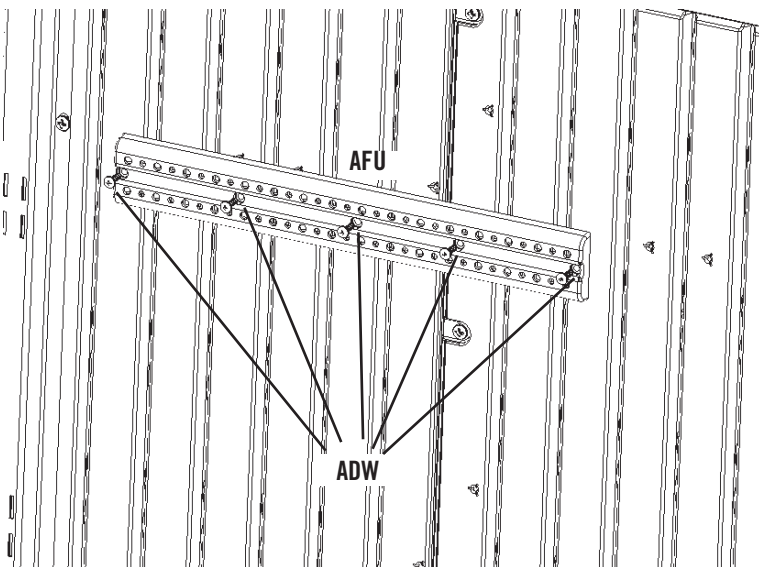

**!** Note: Ensure the Pegboard Strip is level before inserting Screws.

SEC

12.2

Insert **Hooks (AIF, AIG, AIH, AII, and AIJ)**.

**SEC 13 FINAL STEPS**

***HARDWARE REQUIRED***

**NO HARDWARE REQUIRED FOR THIS SECTION**

***METAL PARTS REQUIRED***

**NO METAL PARTS PROVIDED FOR THIS SECTION**

***PLASTIC PARTS REQUIRED***

**NO PLASTIC PARTS REQUIRED FOR THIS SECTION**

***TOOLS REQUIRED***

***PARTS KIT REQUIRED: BOD***



**Rubber Mallet**



**AIX (x4)  
Wood Shim (Included)**

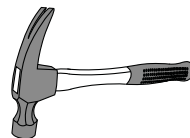

**Hammer**



**Safety Glasses**



## TOOLS AND HARDWARE REQUIRED FOR THIS PAGE

SEC. 12

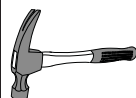

AIX (x4)



NO HARDWARE PROVIDED FOR THIS STEP

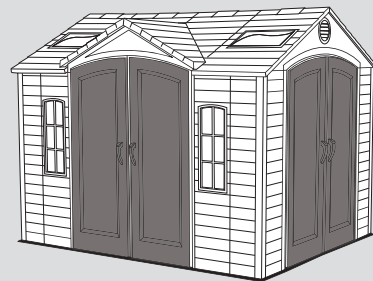

SEC

13.1

### DOOR ALIGNMENT

In some cases, the Doors may not completely line up at the top (fig. 1). When this happens, identify which side is higher and use a **Wood Shim (AIX)** to slightly raise the back corner of the high side until Doors line up (fig. 2). If Doors need further adjustment, insert another Shim under the front corner opposite of the first Shim. If the doors still need further adjustment, stack additional Shims (one at a time) alternating between the back and front Shims. After Doors are aligned, cut off any portion of wood Shim that is still exposed. From inside the Shed, drive a 1" nail through the floor into the Shim to hold it in place. **Tighten all anchoring hardware now.**

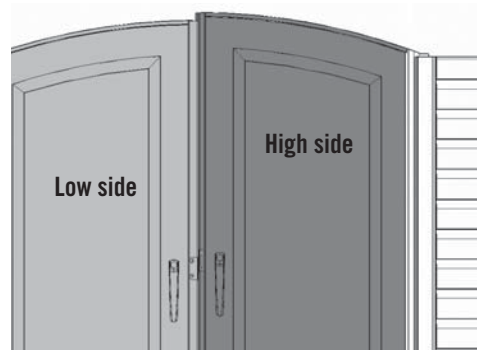

Fig. 1

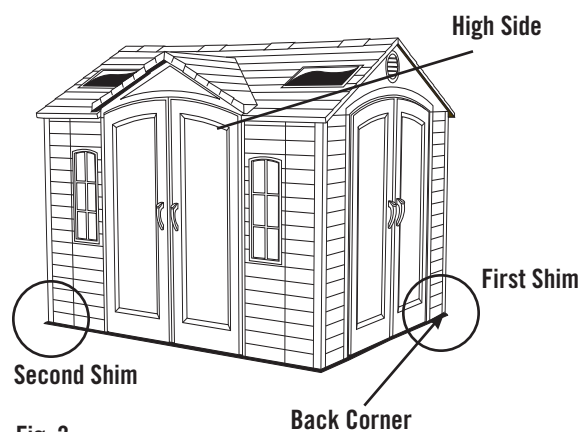

Fig. 2



*Note: Shim should be placed at the corner, running directly under one wall.*

## ***CLEANING & CARE***

Congratulations on your Lifetime® product purchase. By following the instructions below, your new Lifetime product should provide you with years of service and enjoyment.

### **Cleaning and Care**

The polyethylene panels are stain- and solvent-resistant. Most stains can be removed, using a mild soap and a soft-bristled brush. Abrasive cleaning materials may scratch the plastic and are not recommended. Repair scratches or rust spots on the metal by sanding the affected area lightly; using a rust preventative spray primer; and finally, spraying with a high-gloss spray enamel paint. Avoid placing a direct heat source on or near surfaces unless using a heat barrier.



## LIFETIME OUTDOOR SHED EQUIPMENT

### 10-YEAR LIMITED FACTORY WARRANTY

**THE MANUFACTURER RESERVES THE RIGHT TO MAKE SUBSTITUTIONS TO WARRANTY CLAIMS IF PARTS ARE UNAVAILABLE OR OBSOLETE.**

1. Lifetime outdoor sheds are warranted to the original purchaser to be free from defects in material or workmanship for a period of ten years from the date of original retail purchase. The word “defects” is defined as imperfections that impair the use of the product. Defects resulting from misuse, abuse or negligence will void this warranty. This warranty does not cover defects due to improper installation, alteration or accident. This warranty does not cover damage caused by vandalism, rusting, “acts of nature” or any other event beyond the control of the manufacturer.
2. This warranty is nontransferable and is expressly limited to the repair or replacement of defective product. If the product is defective within the terms of this warranty, Lifetime Products, Inc. will repair or replace defective parts at no cost to the purchaser. Shipping charges to and from the factory or distribution center are not covered and are the responsibility of the purchaser. Labor charges and related expenses for removal, installation or replacement of the shed or its components are not covered under this warranty.
3. This warranty does not cover scratching or scuffing of the product that may result from normal usage. In addition, defects resulting from intentional damage, negligence, unreasonable use or hanging from the truss will void this warranty.
4. Liability for incidental or consequential damages is excluded to the extent permitted by law. While every attempt is made to embody the highest degree of safety in all equipment, freedom from injury cannot be guaranteed. The user assumes all risk of injury resulting from the use of this product. All merchandise is sold on this condition, and no representative of the company may waive or change this policy.
5. This product is not intended for institutional or commercial use; Lifetime Products, Inc. does not assume any liability for such use. Institutional or commercial use will void the warranty.
6. This warranty is expressly in lieu of all other warranties, expressed or implied, including warranties of merchantability or fitness for use to extent permitted by Federal and state law. Neither Lifetime Products, Inc., nor any representative assumes any other liability in connection with this product. This warranty gives you specific legal rights, and you may also have other rights which vary from state to state.

#### **PLEASE INCLUDE YOUR DATED SALES RECEIPT AND PHOTOGRAPHS OF DAMAGED PARTS.**

REPORT PRODUCT DEFECTS IN WRITING TO:

Lifetime Products, Inc., PO Box 160010 Clearfield, UT 84016-0010  
or call 1-800-225-3865 M-F 7 a.m. to 5 p.m. MST.

#### **REGISTER YOUR PRODUCT FOR QUICKER CUSTOMER SERVICE.**

Visit [www.lifetime.com](http://www.lifetime.com) or call 1-800-225-3865 to register your product today.

#### **FOR INTERNATIONAL WARRANTY CLAIMS:**

All warranty claims must be accompanied by a sales receipt. Report all warranty claims in writing to your regional sales support representative. Please include your dated sales receipt and photographs of damaged parts.

To Identify the representative for your region — Please visit: [www.lifetime.com/international](http://www.lifetime.com/international)



[www.lifetime.com](http://www.lifetime.com)

**ENHANCE YOUR LIFETIME® PURCHASE BY ADDING ACCESSORIES OR OTHER GREAT PRODUCTS**

---

*To purchase accessories or other Lifetime Products, visit us at:*

***[www.lifetime.com](http://www.lifetime.com)***

***Or call: 1-800-424-3865***

---

